

INTRODUCTION

The **RS2-GSM** is an intercom unit which as a cell phone can call the owner's mobile or landline phone. By pressing the call button on the intercom, it makes the voice connection in a few seconds, just like when talking via a conventional intercom system. This way it makes possible for the owner to receive the visitor's calls and talk to them at anytime and anywhere, even when not at home.

The unit does not need any special installation or complicated wiring, it needs power only and an active SIM card.

FUNCTIONS

- Wireless intercom with 2 pushbuttons (for 1 or 2 apartments)
- 2 phone numbers can be assigned to each pushbutton (set as primary and secondary)
- Gate control function by free call, 100 user phone numbers can be configured
- Direct control for electric lock, can be controlled during the conversation using the phone's keys
- The output can be activated by pushing the unit's call button (existing doorbell can be connected)
- The outputs can be controlled by the contact input (optional button for local control of the electric lock)
- SMS forwarding (e.g. to forward the balance information of pre-pay SIM card)
- Configuring via USB using the PC software found in the intercom unit
- Remote configuring by SMS message



FEATURES

- Compact design, all functions on 1 panel
- Wide power voltage range, from 14V to 24V DC or AC, regardless to polarity
- Solar powered version is available (RS2-GSM-S)
- 1 contact input
- 1 relay output, max load: 1A@24V DC
- 1 voltage output with short circuit and overcurrent protection, max power: 1A@12V DC
- Programming port: mini USB B type
- Communication: (2G) GSM 850, EGSM 900, DCS 1800, PCS 1900 MHz
- Network independent, accepts any SIM card
- Operating temperature: -30°C / +60°C
- Protection: IP54

APPLICATION AREA

- Modern solution for wireless intercom system (private homes, resorts, offices, premises)
- Remotely controllable access control unit
- Keyless door opening
- Garage door opening/closing by phone
- Emergency call unit
- Info columns

ADVANTAGES

- No missed clients or visitors, since the intercom unit calls the owner's mobile phone, no matter where the owner is.
- On call, the owner can let in the guest, client or courier remotely.
- In case of absence, burglary attempts can be prevented by imitating the apparent presence.
- Fast and easy installation, easy configuration using a PC.
- The solar powered version can be operated where no power supply is available.
- Possibility for communication from any fixed place.



OPERATION

Visitor mode

When the visitor pushes the call button, the device initiates a voice call to the configured phone number. If the called party accepts the call, the communication establishes for the configured duration. During the call, the connection cannot be interrupted nor by making a call to the device, nor by pressing the button again. The call is ended automatically when the configured communication time expires, or the called party can hang up the call at anytime on his/her phone. The call is ended automatically if the called party does not answer or is not available. A new call is initiated only if the button is pressed again.

Listen-in mode

The intercom unit can be called from any phone number. In this case the unit accepts the call without ringing and the voice connection establishes. The call can be ended on the caller's phone or by pressing the call button on the unit.

If the call is initiated from a phone number which is configured in the unit as gate opener number, the device will consider the call as a gate opening call. In this case voice connection is not established, but the relay output is activated.

To make a "listen-in" call from such phone number, use the **#31#** code in front of the number, this hides the caller's phone number (e.g.: #31#0036301234567). The unit will already accept the call received from unknown phone number.

Controlling the relay output

The *RELAY* (normally open, NO) relay output can be controlled as follows, depending on the usage:

- **controlling by free call:**
on incoming call, after identifying the caller ID, the unit rejects the call and activates the output
e.g. garage door or barrier opening, for which max 100 user phone numbers can be configured
- **controlling by the pushbutton:**
the relay activates when the call button is pushed
e.g. possibility to connect an existing door bell
- **controlling by the INPUT contact input:**
the relay activates on external contact
e.g. garage door opening or closing

ATTENTION:

The *RELAY* and *-OUT+* outputs is activated in parallel and independently from each other by both menu items, the *Control of outputs* and the *Gate control*. Please take this into consideration when planning the usage!

Controlling the voltage output

The *-OUT+* voltage output can be controlled as follows:

- **controlling by the INPUT contact input:**
after activating the input, the output activates for the configured time period
e.g. optional indoor pushbutton for electric lock control
- **controlling by the phone's keys:**
by pressing any of the phone's numbered keys the output activates for the configured time period
e.g. direct control of the electric lock

The voltage output is protected against short circuit and overcurrent, thereby the output turns off upon overcurrent and becomes operable again after the termination of the fault.

Forwarding incoming SMS messages

The unit forwards the SMS messages received on its SIM card (e.g. balance information in case of a prepaid card) to the configured phone number. After forwarding, the received message is deleted from the SIM card. If there is no phone number configured, the unit deletes the incoming messages without forwarding.

Status LED indications

LED	Color	
GSM OK	green	Is lit after connecting to the GSM network and reaching the sufficient GSM signal. The sufficient signal is: 10 (on 0-31 scale)
GSM / SIM ERROR	red	Is lit continuously if the device cannot connect to the GSM network. Possible reasons: - the GSM antenna is faulty or is not connected - the SIM card is not inserted, - or the PIN code request is not disabled, - or the SIM card is faulty.
CALL IN PROGRESS	green	Communication in progress. A call or conversation is in progress.
-OUT+	red	Voltage output activated
RELAY	red	Relay output activated

SETTING WITH MS WINDOWS APPLICATION

The intercom unit parameters (phone numbers, controls) can be configured using the *Intercom configurator* software found on the internal storage of the device. You can run the program directly from the unit's drive after connecting to USB (Windows XP and Windows 7 compatible).

Intercom configurator V1.00

Beállítások

Upper button

Primary phone number: 00363011111111

Secondary phone number: 00362077777777 Automatic

Lower button

Primary phone number: 00367033333333

Secondary phone number: Automatic

Control of outputs

OUT Push button: NO

RELAY Push button: NO

General settings

Ring time (sec): 20

Call time (sec): 120

OUT activation time (sec): 5

RELAY activation time (sec): 3

Incoming SMS forwarding: 00363011111111

Gate controlling

Recorded users

Phone number: 00363011111111 **4/100** RELAY OUT

New user

Phone number: RELAY OUT

Status information

Intercom

Module type: **RS2-GSM**

Firmware version: **V1.22**

Inputs

Upper button: **IDLE**

Lower button: **IDLE**

INPUT: **IDLE**

GSM network

GSM signal (0-31): **18**

GSM provider: **T-Mobile H**

Outputs

RELAY: **IDLE**

OUT: **IDLE**

State messages

Outgoing call started...

Call finished.

Call Stop in ring state.

Button1...

VOUT started(5 sec)

Start call[primary]: 00363011111111

VOUT stopped.

Call failed!

Call finished.

Administration operations

These menu items serve for reading, writing, saving etc. the settings.



Read

Click to read and displays the settings from the unit.

Write

Click to write the settings to the unit's memory.

Save

Click to save the settings to file.

Open

Click to open saved settings from file.

Firmware

Click to update the intercom's firmware.

English/Magyar

Click to change the *Intercom configurator's* interface language.

Progress bar

Buttons

The intercom unit calls the phone numbers entered here when the appropriate button is pressed. If both phone numbers are set to any button, the unit calls the primary phone number first.

In case of an unsuccessful call (e.g. if the called number is not available or the call is not accepted), calling the secondary phone number can be done by pushing the button again (within 60 seconds). If the **Automatic** option is enabled, then the unit calls the secondary phone number if the primary fails without having to push the button again.

Control of outputs

The two outputs of the unit can be controlled by multiple configured events. You can choose the activation event according to the usage.

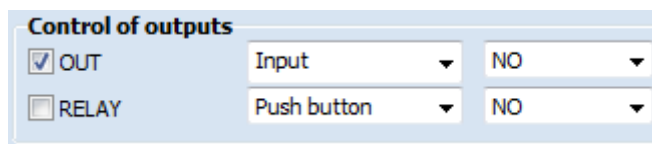

OUT

The voltage output, e.g. for direct control of an electric lock.

RELAY

The relay contact output, e.g. for garage door control.

You can select the activation event and the normal state of the output (idle state) from the drop-down menus. Upon activation, the output state changes for the configured time period.

General settings

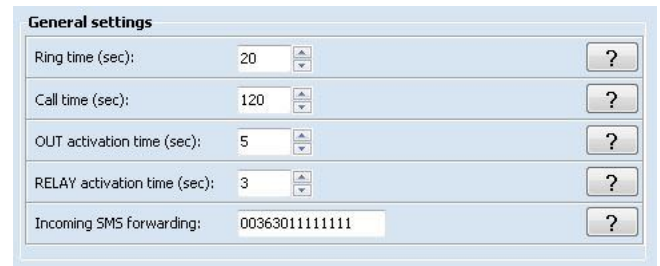

Ring time (10-120 sec)

The maximum time allowed for ringing from pushing the call button. This function is useful to avoid switching to voicemail.

Call time (10-600 sec)

The maximum time allowed for a call initiated from the intercom.

OUT active time (1-120 sec, monostable)

The voltage output activation time.

RELAY active time (1-120 sec, monostable)

The relay contact output activation time.

SMS forward

Forwards the SMS messages received on the unit's SIM card to the specified phone number, e.g. balance information received from the GSM service provider. It is recommended to configure this in case of using a pre-pay type SIM card.

Gate control

When calling the intercom from the phone numbers specified here, control of the output or outputs assigned to the given phone number is performed. The incoming call is not accepted, thereby this function works with free calls. Maximum 100 user phone numbers can be added.

Status information

Displays information about the switching state of the peripherals and the actual status of the mobile network.

State messages

The messages shown in this window give information about the internal operation of the unit. This helps in identifying an internal process, an incorrect configuration or other malfunction.

The question marks placed next to the settings in the **Intercom configurator** give assistance to the parameter settings of the given section.

SETTING WITH SMS COMMANDS

Configuration of the unit is possible by sending the appropriate commands in SMS to the module's phone number. It is possible to send more commands (settings) in the same SMS, but the length of the message must not exceed 140 characters! Each message must begin with the password using the **PWD=password#** command and each command must end with **#** character, else the module does not apply the modifications. The following table contains the configuring and query commands:

Configuration commands	
PWD=1234#	Password for programming, default setting:1234
PWC=new password #	Changing the password. The password is a 4-digit number.
RESET#	Resetting the settings and the password to default.
UPTTEL1=phone number#	Primary phone number for upper pushbutton.
UPTTEL2=phone number#	Secondary phone number for upper pushbutton.
UPAUTO=ON# vagy OFF#	In case the call to UPTTEL1 fails, UPTTEL2 phone number will be called without having to push the button again, if the parameter is ON.
LOWTEL1=phone number#	Primary phone number for lower pushbutton.
LOWTEL2=phone number#	Secondary phone number for lower pushbutton.
LOWAUTO=ON# or OFF#	In case the call to LOWTEL1 fails, LOWTEL2 phone number will be called without having to push the button again, if the parameter is ON.
OUT=activation event#	Voltage output control: OFF : disable, BUTTON : when button is pressed INPUT : when input is activated, PHONE : during call, pressing any of the phone's keys, IN+PHONE : INPUT and PHONE enabled
RELAY=activation event#	Relay control: OFF : disable, BUTTON : when button is pressed INPUT : when input is activated
RINGTIME=duration#	Ringing time of the telephone to restrict the reach of voice mail. (10-120sec)
CALLTIME=duration#	Maximum duration of the conversation. (10-600 sec)
RTIME=duration*NO# or NC	Duration and idle mode of the relay output activation. (1-120 sec)
OUTTIME=duration*NO# or NC	Duration and idle mode of the voltage output activation. (1-120 sec)
RTEL=phone number*REL*OUT#	Setting the phone numbers for relay or voltage output activation. For output activation the suffix after the phone number is necessary. *REL : switch the relay, *OUT : switch the voltage out, *REL*OUT switch both. Up to 100 users.
RTELDEL=phone number#	Delete the selected phone number.
STATUS?#	Query of the settings except RTEL list.
INFOSMS=phone number#	Forwards the incoming SMS messages.

This scenario shows the configurations for the following requirements: phone number 2 only for upper pushbutton, auto switch to the secondary phone, VOUT control (for electric lock) by phone and input contact, duration is 10sec, both phone numbers are able to control the gate control's relay by a free call, relay activation time is 5sec. Other call parameters: Ringingtime=25sec; maximum duration of the conversation=120sec; forwarding prepaid card information to primary phone number

SMS message:

```
PWD=1234#UPTTEL1=003630999999#UPTTEL1=003620111111#UPAUTO=ON#OUT=IN+PHONE#
OUTTIME=10*NO#RTEL=003630999999*REL#RTEL=003620111111*REL#RTIME=5*NO#
RINGTIME=25#CALLTIME=120#INFOSMS=003620111111#
```

INSTALLATION

Mounting

- Measure the GSM signal with your mobile phone. It may happen that in the desired place of installation the signal strength is not satisfactory. In this case you can move the unit or the GSM antenna in a more suitable place before installation.
- Do not mount the unit where it could be affected by strong electromagnetic disturbances.
- Antenna: the GSM antenna supplied with the unit provides good transmission under normal reception circumstances. In case of having signal strength problems and/or noisy communication, use other type of higher gain antenna or find a more suitable place for the antenna.
- Inserting the SIM card: pull the metallic part of the SIM case towards the center of the panel to open up the SIM slot for inserting the card. Insert the SIM card into the slot so that its contact surface should point towards the contact pins of the card case when turned down, as well as the cut corner of the card should fall towards the edge of the panel, in the direction of the LEDs. Fasten the SIM card by pulling back the metallic part of the SIM case.

Putting into operation

- Disable PIN code request, voicemail and missed call notification service on the SIM card.
- Enable caller identification and caller ID sending service on the SIM card at the GSM service provider.
- Make sure the SIM card is inserted properly into its case.
- Make sure the antenna is fixed properly into the SMA connector.
- Make sure the wires are connected as shown in the connection diagram.
- Make sure the power supply is sufficient for the operation of the unit! If it is, and all connections are done, the unit can be powered up.

If operated without an electric lock from a 16V AC transformer, the current requirement is 300mA (5VA).

When operated with an electric lock, the minimum power requirement is 20VA!

Connection diagram

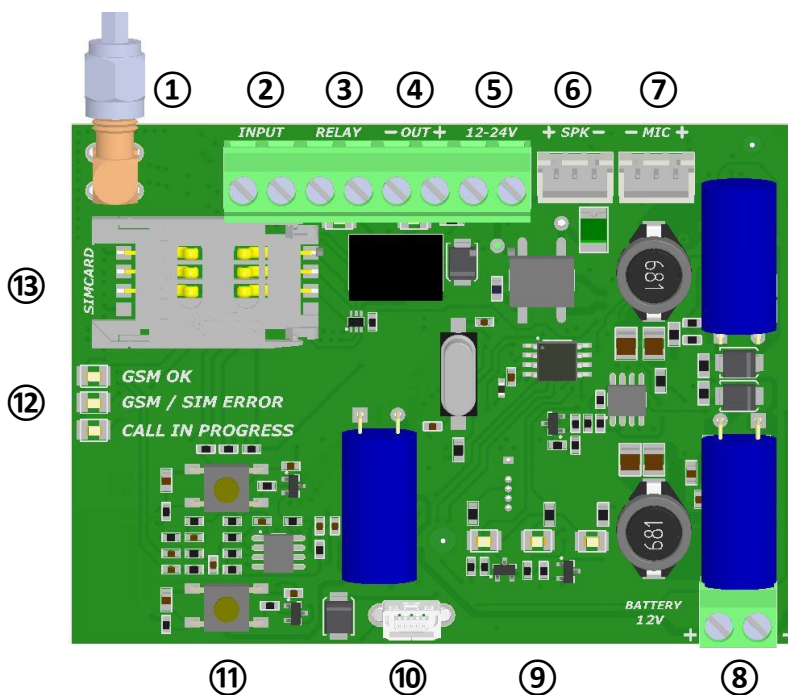

- ① **GSM antenna connector**
- ② **Contact input**
- ③ **Relay contact output**
- ④ **Voltage output**
- ⑤ **Power input**
- ⑥ **Speaker output**
- ⑦ **Microphone input**
- ⑧ **Battery connector**
solar powered version only!
- ⑨ **Name plate lighting**
- ⑩ **USB mini B port**
- ⑪ **Call pushbuttons**
- ⑫ **Status LEDs**
- ⑬ **SIM card case**

TECHNICAL SPECIFICATION

Name	Other conditions	Minimum	Typical	Maximum	Unit
Power supply	DC mode	14	24	34	VDC
	AC mode	12	16	24	VAC
Current consumption	for 16VDC	40	50	400	mA
Relay output load	DC switching			24	V
				1	A
	AC switching			30	V
				0.5	A
Voltage output		11.5	12	13	V
				1	A
Contact input switching		0	0	100	Ohm
Operating temperature		-30		+60	°C
Outdoor protection				IP54	

Other data

Transmission frequency GSM850 / EGSM900
 DCS1800 / PCS1900

Dimensions height:165mm
 width:122mm
 depth: 40mm

Package contents

- RS2-GSM
- GSM 900MHz / 1800MHz antenna
- Antenna bracket + fixing screws