

VIKING PRODUCT MANUAL

SECURITY & COMMUNICATION SOLUTIONS

K-1900-6-IP / EWP
K-1900-7-IP / EWP

VoIP Panel Phones with
Auto Dialer and Relay Control

July 6, 2016

Vandal Resistant VoIP Panel Phones with Auto Dialer and Relay Control

The **K-1900-6-IP** and **K-1900-7-IP** VoIP Panel Phones will auto-dial a 1-20 digit programmable phone number each time the handset is lifted. If the call is not answered, the phone will dial up to 4 additional phone numbers. The **K-1900-6-IP** and **K-1900-7-IP** phones are designed to provide quick and reliable communication for SIP VoIP phone systems with PoE. The unit can be programmed from any PC on the same LAN or remotely using a Static IP Address.

When a call initiated by the **K-1900-6-IP** or **K-1900-7-IP** phone is answered by an apartment or business tenant, a built-in relay may be activated to control an electric gate or door strike. The relay can also be programmed to activate whenever the phone is off hook, ideal for controlling cameras, etc.

The **K-1900-6-IP-EWP** and **K-1900-7-IP-EWP** share all of the features of the standard **K-1900-6-IP** and **K-1900-7-IP** in addition to Enhanced Weather Protection (EWP) for outdoor installations where the unit is exposed to precipitation or condensation. EWP products feature foam rubber gaskets and boots, sealed connections, gel-filled butt connectors, as well as urethane or thermal plastic potted circuit boards. For more information on EWP, see **DOD# 859**.

⚠ Installation requires the assistance of a Network Administrator / IT Technician



K-1900-6-IP
"Brushed 316
Stainless Steel"
(similar to brushed nickel)

K-1900-7-IP
"Brushed 316
Stainless Steel"
(similar to brushed nickel)

Features

- **Vandal Resistant Features:** 12 gauge 316 stainless steel front panel with permanent laser etched graphics. Heavy duty metal hook switch, armored cable and T-10 Security Torx drive mounting screws.
- **Weather Resistant Features:** Marine grade 316 stainless steel faceplate and Torx Security screws. Faceplate, ear piece, and mouth piece gaskets (on EWP models). Weather resistant powder paint on optional **VE-5X10** surface mount box or 316 ss on **VE-5X10-SS**.
- Hearing aid compatible amplified handset with sealed push button volume control
- SPDT 2 Amp relay contacts for door/gate or camera control
- Optional **RC-4A** for Secure Remote Relay Control, see **DOD# 582**
- SIP compliant (see pg 2 for list of compatible IP-PBX phone systems)
- PoE powered (class 1, <4 watts)
- Automatic Noise Canceling (ANC) feature for clear audio in noisy environments
- Network downloadable firmware
- Standard **K-1900-6-IP** and **K-1900-7-IP**: 36" armored handset cable
- **K-1900-6-IP-EWP** and **K-1900-7-IP-EWP**: 54" armored handset cable
- Cycles to up to 4 rollover phone numbers on busy or no-answer
- Optional Enhanced Weather Protection (EWP), EWP products are designed to meet IP66 Ingress Protection Rating, see **DOD# 859**
- Remotely programmable
- Extended temperature range (-40°F to 140°F)
- Selectable auto-answer feature for monitoring
- Optional **VE-5x10** Surface Mount Box or 316 Stainless Steel **VE-5X10-SS**, see **DOD #424** (compatible with model **K-1900-7-IP** only)
- Optional **VE-LIGHT** kit to illuminate the front panel at night, see **DOD# 428** (compatible with model **K-1900-7-IP** only)
- Self diagnostics for testing relay

Applications

- Commercial or Residential
- Door / Gate Entrance
- Kiosk Phone
- Apartment Entry Phone
- Door Entry Phone
- Courtesy Assistance Phone
- Customer Service Phone
- Automated Teller (ATM) Phone
- Security or Emergency Phone
- Hot-Line Phone
- Prison Phone

Information: 715-386-8861
www.vikingelectronics.com

Specifications

Power: PoE class 1 (<4 watts)
Dimensions for K-1900-6-IP: 4.56" x 4.5" x 3.75" (116mm x 115mm x 95mm)
Dimensions for K-1900-7-IP: 5" x 10" x 4" (127mm x 254mm x 102mm)
Shipping Weight for K-1900-6-IP: 2.0 lbs (0.9 kg)
Shipping Weight for K-1900-7-IP: 3.7 lbs (1.7 kg)
Operating Temperature: -40°F to 140°F (-40° C to 60° C)
Humidity - Standard Products: 5% to 95% non-condensing
Humidity - EWP Products: Up to 100%
Handset Cable Length on Standard Model: 34" to 37"
Handset Cable Length on EWP Model: 53" to 58"
Mounting for K-1900-6-IP: Flush mount to a standard double gang box
Mounting for K-1900-7-IP: Flush mount to a standard double gang box or surface mount using an optional **VE-5x10** (DOD# 424) or **VE-9x20** (DOD# 413)
Audio Codecs: G711u, G711a, G722
Network Compliance: IEEE 802.3 af PoE, SIP 2.0 RFC3261, 100BASE-TX with auto cross over
Connections: (1) RJ45 10/100 Base-T, (14) gel-filled butt connectors

Viking VoIP SIP System Compatibility List

NOTE: Exclusion from this list means only that compatibility has not been verified, it does not mean incompatibility.

For detailed configuration instructions for certain vendors below, see **Configuring Viking VoIP Phone and SIP Servers, DOD# 944.**

Vendor	Infrastructure Class				
	Softswitch	PBX	Proxy	SBC (session border controller)	Service Provider
3COM VCX		X			
3CX		X			
Aastra		X			
Asterisk		X			
Atcom		X			
Avaya Aura Communication Manager					
Avaya IP Office		X			
BlueBox		X			
Brekeke		X			
Callcentric					X
Cisco Unified Communications Manager (CUCM)	X	X			
Cisco Unified Communications Manager Express (CUCME)	X	X			
Elastix		X			
Freeswitch		X			
Grandstream		X			
Interactive Intelligence	X	X			
iptel.org					X
Kamailio			X	X	
MetaSwitch				X	X
NEC		X			
OfficeSIP		X			
OpenSIPS		X			
Panasonic** (with SIP Extension Card)		X			
Samsung Communications Manager (SCM)	X	X			
ShoreTel*		X			
Siemens Communications Server (SCS)		X			
SIP Express Router (SER)			X	X	
sip.antisip.com					X
Snom PBX		X			
Sonus				X	
Switchvox		X			X
Teksip			X		
Toshiba		X			
VoIP.ms					X

* **Note:** Not compatible with ShoreTel Ring Group/Hunt Group (unit can be programmed to ring an extension 2 or 3 times then roll to the next number, for a total of 5 numbers).

** **Note:** Relay operation commands are Not compatible with Panasonic Phone Systems (Panasonic does not transmit DTMF between station ports).

Known Incompatible System or Service Provider: Ring Central (Requires Authorization ID and Proxy address).

Definitions

Client: A computer or device that makes use of a server. As an example, the client might request a particular file from the server.

DHCP: Dynamic Host Configuration Protocol. In this procedure the network server or router takes note of a client's MAC address and assigns an IP address to allow the client to communicate with other devices on the network.

DNS Server: A DNS (Domain Name System) server translates domain names (ie: www.vikingelectronics.com) into an IP address.

Ethernet: Ethernet is the most commonly used LAN technology. An Ethernet Local Area Network typically uses twisted pair wires to achieve transmission speeds up to 1Gbps.

Host: A computer or device connected to a network.

Host Name: A host name is a label assigned to a device connected to a computer network that is used to identify the device in various forms of network communication.

Hosts File: A file stored in a computer that lists host names and their corresponding IP addresses with the purpose of mapping addresses to hosts or vice versa.

Internet: A worldwide system of computer networks running on IP protocol which can be accessed by individual computers or networks.

IP: Internet Protocol is the set of communications conventions that govern the way computers communicate on networks and on the Internet.

IP Address: This is the address that uniquely identifies a host on a network.

LAN: Local Area Network. A LAN is a network connecting computers and other devices within an office or building.

Lease: The amount of time a DHCP server reserves an address it has assigned. If the address isn't used by the host for a period of time, the lease can expire and the address can be assigned to another host.

MAC Address: MAC stands for Media Access Control. A MAC address, also called a hardware address or physical address, is a unique address assigned to a device at the factory. It resides in the device's memory and is used by routers to send network traffic to the correct IP address. You can find the MAC address of your **K-1900-6-IP** or **K-1900-7-IP** phone printed on a white label on the top surface of the PoE LAN port.

Router: A device that forwards data from one network to another. In order to send information to the right location, routers look at IP Address, MAC Address and Subnet Mask.

RTP: Real-Time Transport Protocol is an Internet protocol standard that specifies a way for programs to manage the real-time transmission of multimedia data over either unicast or multicast network services.

Server: A computer or device that fulfills requests from a client. This could involve the server sending a particular file requested by the client.

Session Initiation Protocol (SIP): Is a signaling communications protocol, widely used for controlling multimedia communication sessions such as voice and video calls over Internet Protocol (IP) networks. The protocol defines the messages that are sent between endpoints, which govern establishment, termination and other essential elements of a call.

Static IP Address: A static IP Address has been assigned manually and is permanent until it is manually removed. It is not subject to the Lease limitations of a Dynamic IP Address assigned by the DHCP Server. The default static IP Address is: **192.168.154.1**

Subnet: A portion of a network that shares a common address component. On TCP/IP networks, subnets are defined as all devices whose IP addresses have the same prefix. For example, all devices with IP addresses that start with 100.100.100. would be part of the same subnet. Dividing a network into subnets is useful for both security and performance reasons. IP networks are divided using a subnet mask.

TCP/IP: Transmission Control Protocol/Internet Protocol is the suite of communications protocols used to connect hosts on the Internet. TCP/IP uses several protocols, the two main ones being TCP and IP. TCP/IP is built into the UNIX operating system and is used by the Internet, making it the de facto standard for transmitting data over networks.

TISP: Telephone Internet Service Provider

WAN: Wide Area Network. A WAN is a network comprising a large geographical area like a state or country. The largest WAN is the Internet.

Wireless Access Point (AP): A device that allows wireless devices to connect to a wired network using Wi-Fi, or related standards. The AP usually connects to a router (via a wired network) as a standalone device, but it can also be an integral component of the router itself.

Wireless Repeater (Wireless Range Extender): takes an existing signal from a wireless router or access point and rebroadcasts it to create a second network. When two or more hosts have to be connected with one another over the IEEE 802.11 protocol and the distance is too long for a direct connection to be established, a wireless repeater is used to bridge the gap.

Features Overview

Front View of the K-1900-6-IP VoIP Panel Phone

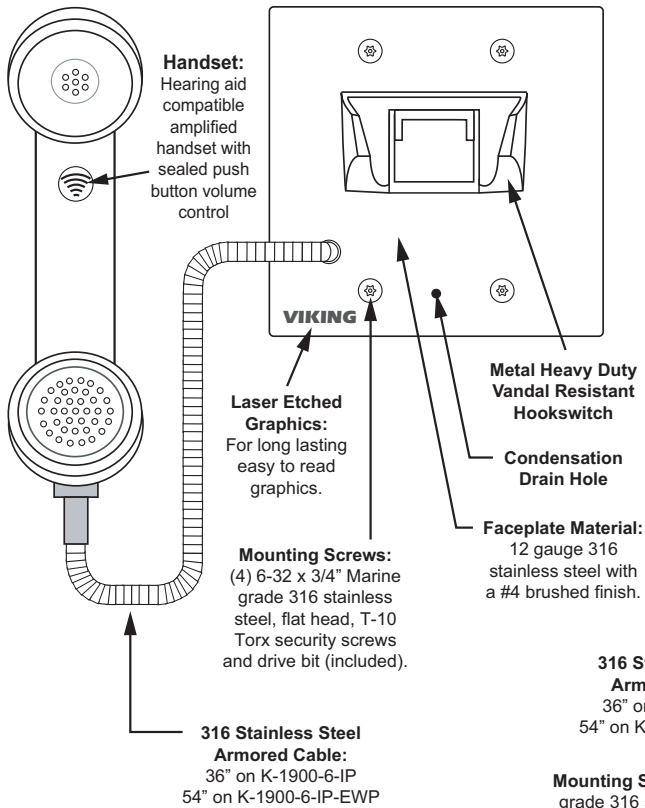

Front View of the K-1900-7-IP VoIP Panel Phone

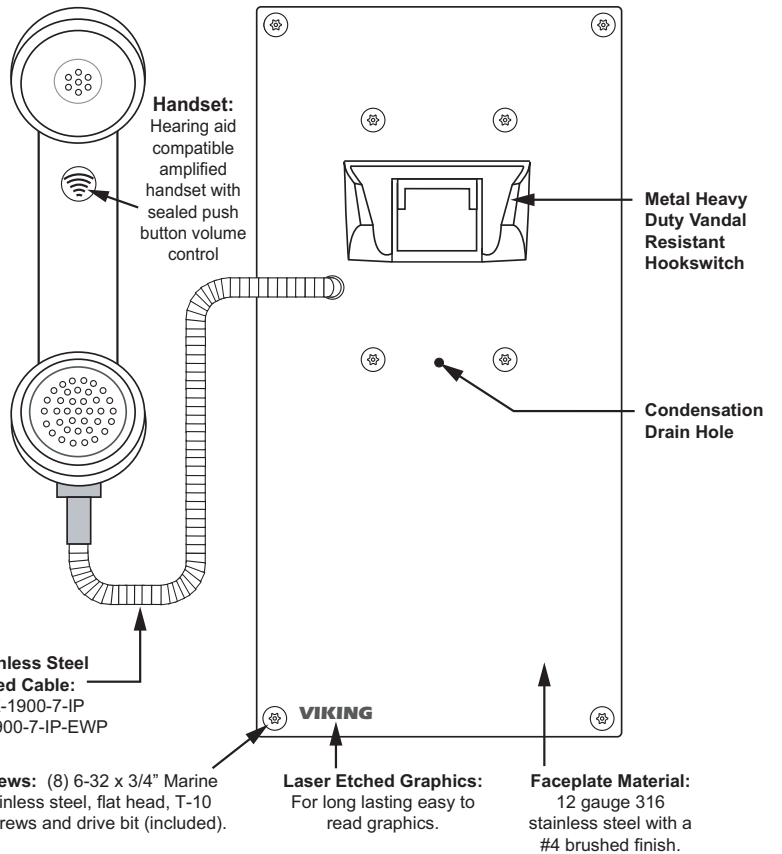

Rear (PCB) View of the K-1900-6-IP or K-1900-7-IP

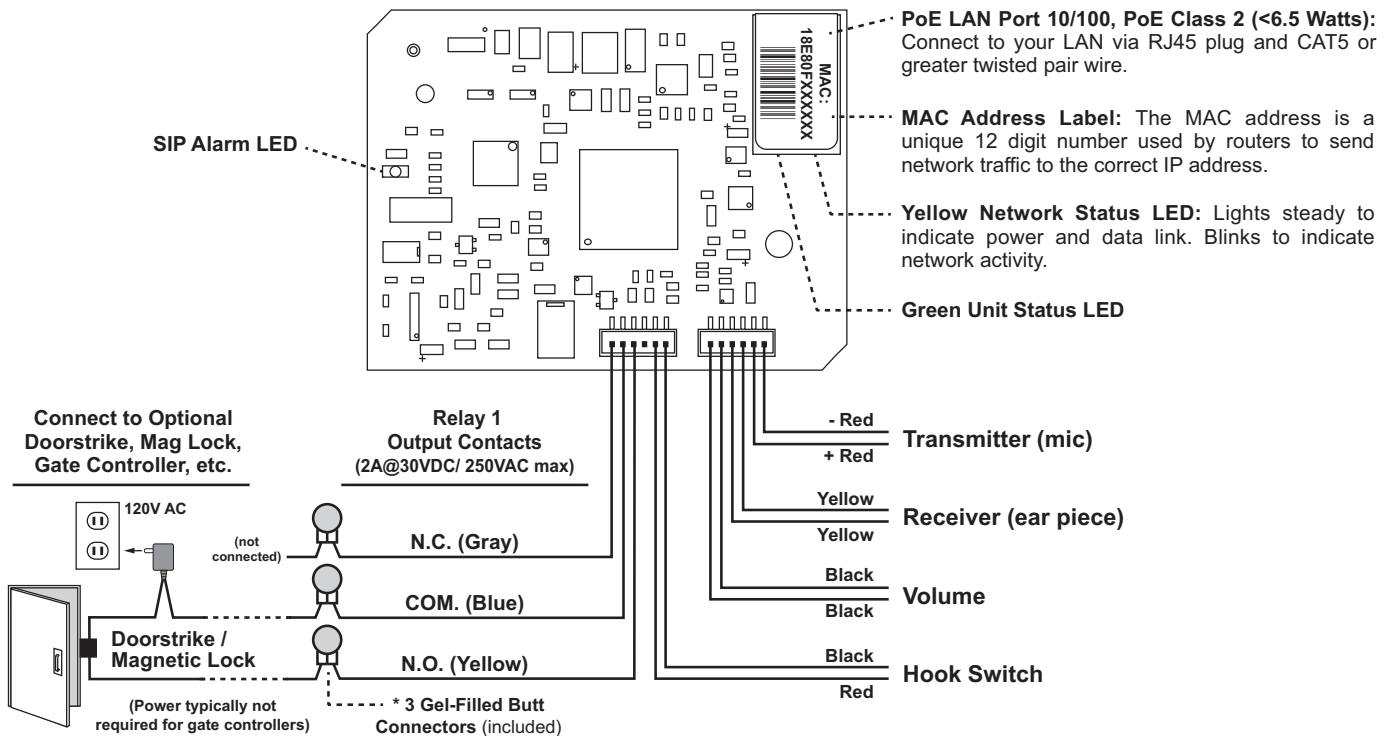

***Note:** The gel-filled (water-tight) butt connectors are designed for insulation displacement on 19-26 gauge wire with a maximum insulation of 0.082 inches.

Installation and Mounting

A. Installing the K-1900-6-IP

To install the **K-1900-6-IP** panel phone, attach the panel to a standard double gang electrical box using the provided screws.

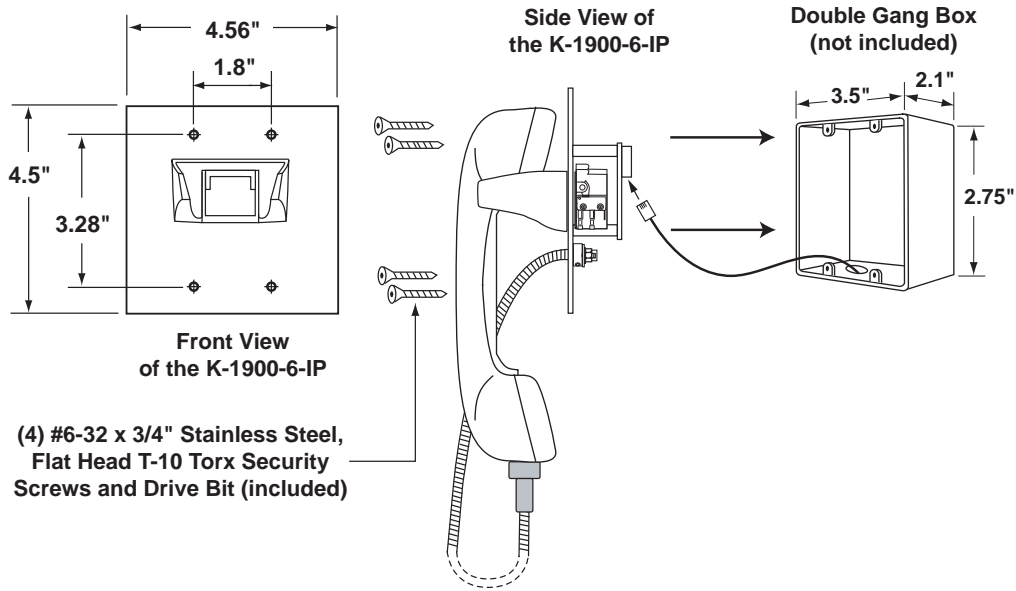

B. Installing the K-1900-7-IP

To install the **K-1900-7-IP** panel phone, attach the panel to a standard double gang electrical box using the provided screws or use the optional **VE-5x10** or **VE-5X10-SS** weather resistant surface mount box. **Note:** Four extra screws and nuts are provided to fill the unused mounting holes. The optional **VE-5x10** surface mount box (shown below) is designed to be surface mounted to a wall, post, single gang box or a **VE-GNP** or **VE-GNP-2** goose neck pedestal. The **K-1900-7-IP** can also be mounted in an optional **VE-9x20** Weatherproof Enclosure (**DOD# 413**).

Note: When mounting a **K-1900-7-IP-EWP** in a **VE-9x20**, the length of the handset cable must be reduced. Use a 3/32" hex key or bit to loosen the set screw in the brass handset cable retainer. Pull approximately 18 inches of the cable through the panel and retighten the set screw.

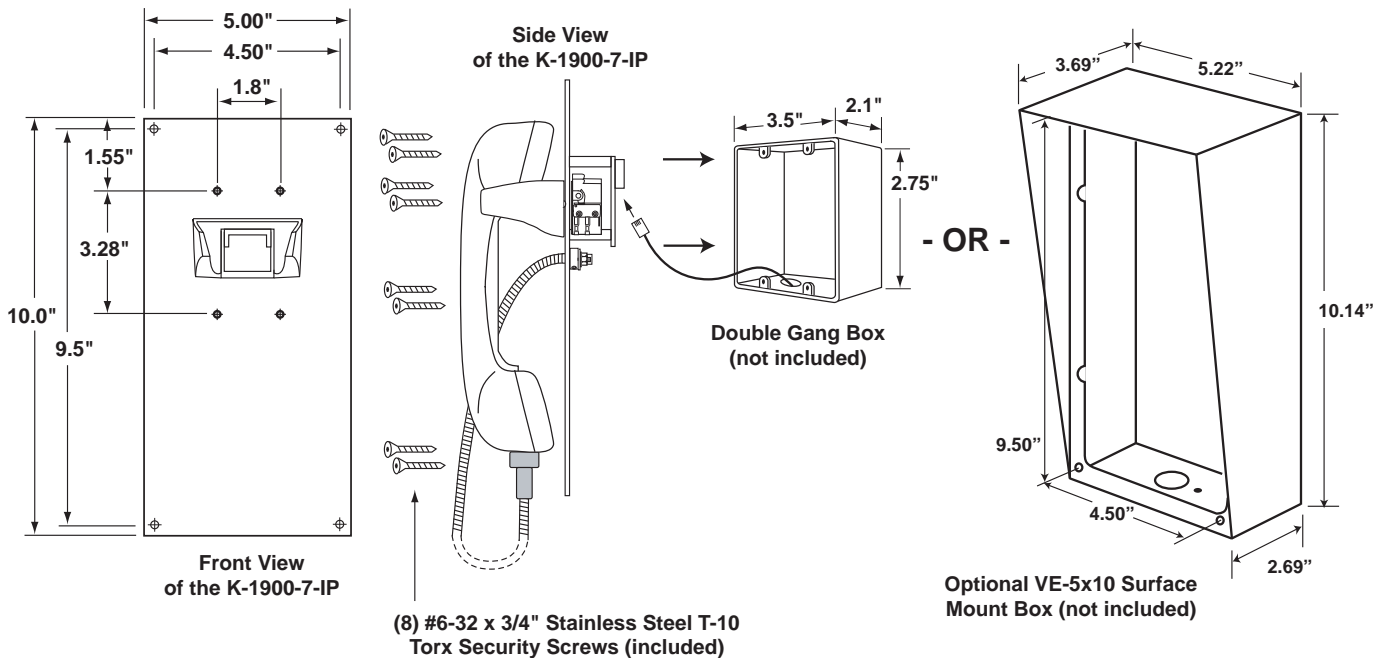

Using a Viking Model RC-4A for Secure Remote Relay Control

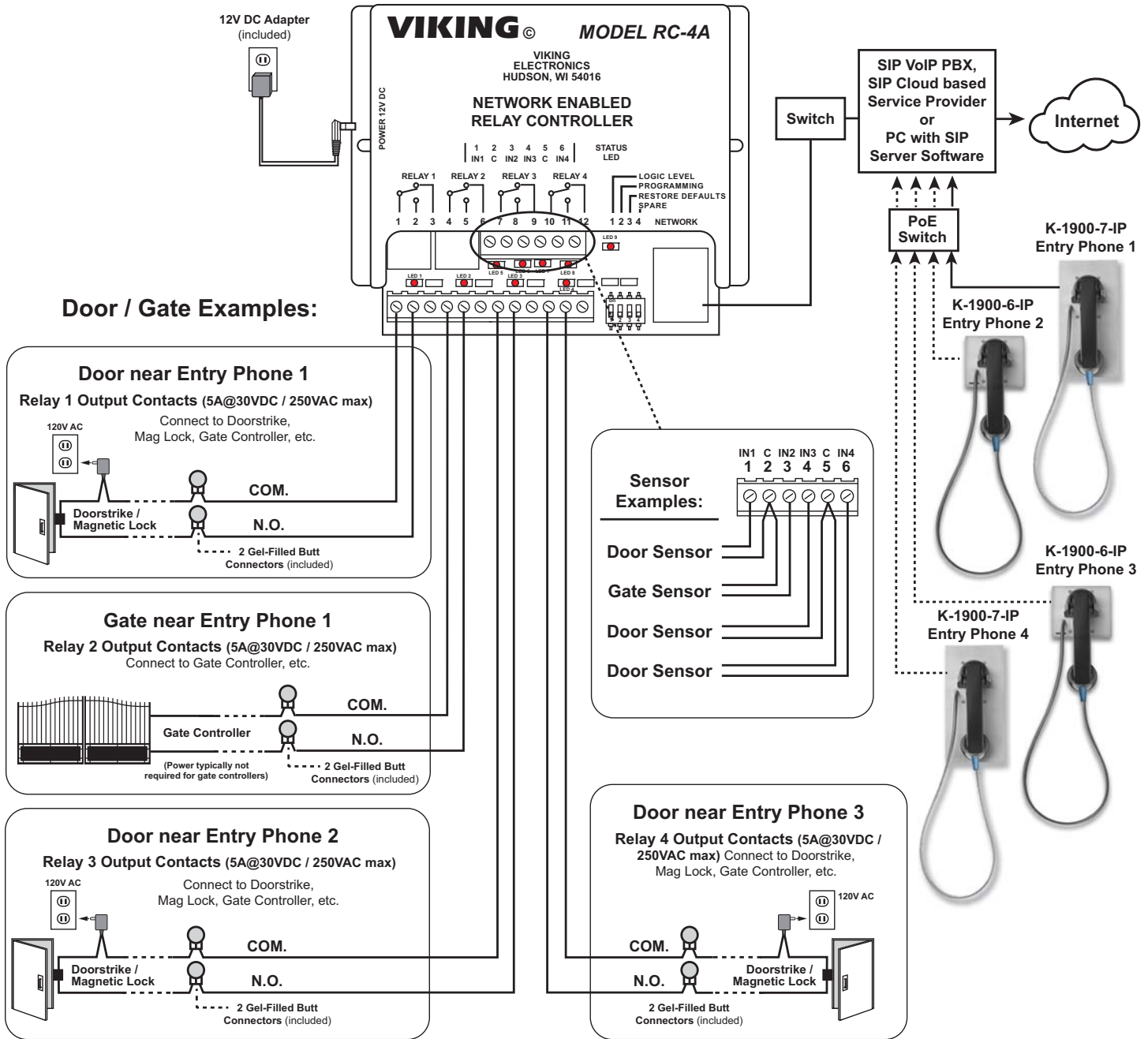

The front panel of the **K-1900-6/7-IP** is mounted using security Torx screws to help prevent intruders from removing the panel and accessing the on board door strike/gate control relays. For applications requiring additional security, a Viking model **RC-4A** remote relay controller can be used. The relay controller is mounted securely inside the building and connected to the same LAN as the **K-1900-6/7-IP**. The on board door strike relay would not be used in this case as the **K-1900-6/7-IP** will send an encrypted message to the **RC-4A** to activate its relays which control the door strikes/gates.

Up to 4 **K-1900-6/7-IP**'s can communicate with one **RC-4A** allowing you to securely control four entrances.

When using a **RC-4A** for remote relay control, the **K-1900-6/7-IP**'s relay should be set to "External" in the PC programming.

Typical Installation on SIP Based VoIP Phone System

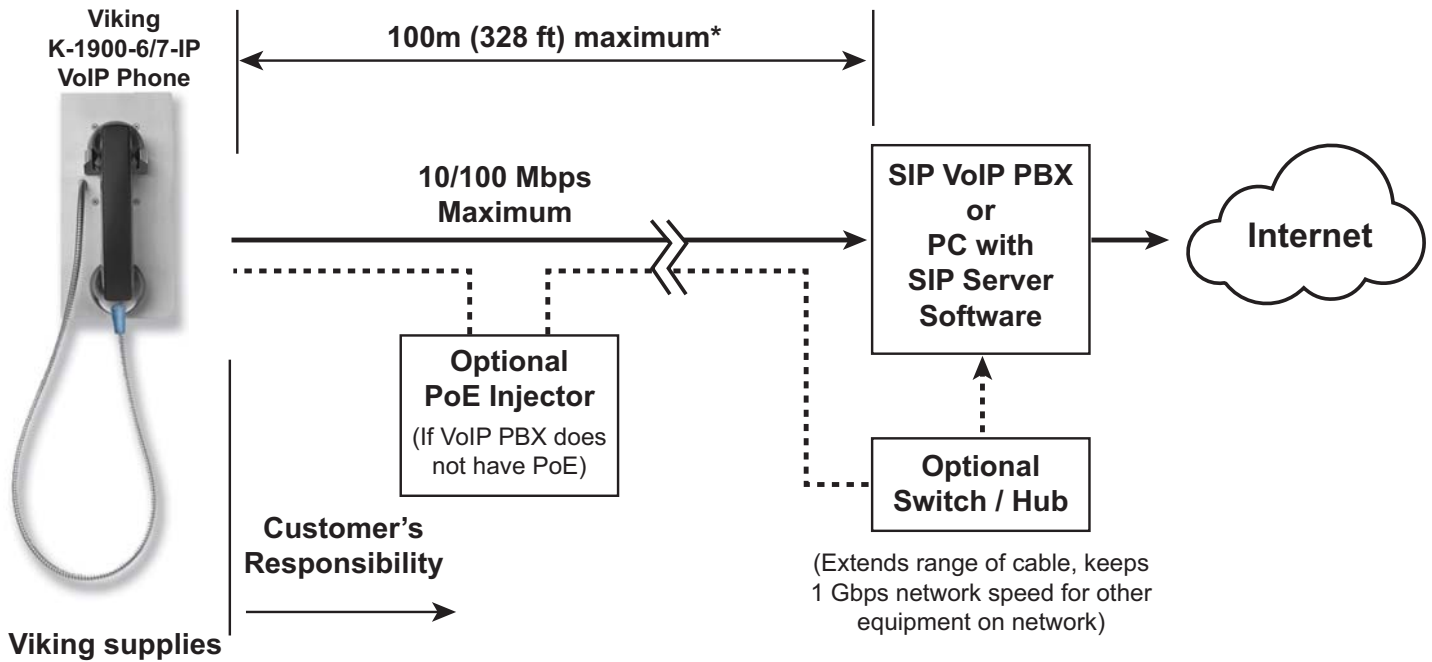

* **Note:** A PoE extender can be used for an additional 100 meters per extender. For longer runs (up to 2 km / 1.2 miles) a ethernet to fiber media converter can be used.

PC Requirements

- **IBM** compatible personal computer with:
 - Windows 2000 (service pack 4 or higher)
 - Windows XP (service pack 2 or higher)
 - Windows Vista (SP2 or newer), 32 or 64 bit versions
 - Windows 7
 - Windows 8
 - Windows 10
- Adobe Acrobat Reader 8 or higher
- **K-1900-6/7-IP** hardware
- Available LAN with PoE (class 1, <4 watts)
- Ethernet cable (CAT5 min.)
- 1 MB minimum free hard drive space for installation
- 16MB of free physical RAM

PC Programming

A DVD is included with each **K-1900-6/7-IP** VoIP Phone. The DVD contains the application "**Viking IP Programming**" used to program the unit using a PC running Windows 2000, XP, Vista, Windows 7, Windows 8 or Windows 10 (see System Requirements above). The PC must be connected to the same LAN as the **K-1900-6/7-IP** VoIP phone. Install the application on your PC by placing the DVD into your PC's drive. Click "I Accept" on the bottom of the first screen, then select "Viking IP Programming" and click the "Install" button. Follow the directions on the screen. To start the Viking IP Programming application, click on the Viking IP Programming icon on your desk top. The Main screen will appear, allowing the user to program any **K-1900-6/7-IP** phone connected to that LAN.

A. Manually Muting SIP/Network Failure Alarm Beeps (3 beeps repeated every 30 seconds)

With the unit connected and powered (Green LED on and Yellow LED off or blinking) it will output 3 beeps every 30 seconds in the handset of the **K-1900-6/7-IP** to indicate a SIP registration failure, failure to receive an echo reply from pinged gateway or Ethernet connection failure. You can manually disable the beeps by clicking the "Mute Current /Next Alarm" button in the Viking VoIP programming software.

B. Configuring the K-1900-6/7-IP Network Settings

Step 1.	Open the “Viking IP Programming” software on a windows PC that is connected to the same LAN as the K-1900-6/7-IP phone to be programmed.
Step 2.	The window will show you each K-1900-6/7-IP phone that is connected to that LAN. Select the unit with the same MAC address shown on the label located on the top of the Ethernet connector on the K-1900-6/7-IP phone.
Step 3.	Click the “Connect” button. If a pop up window appears, enter the unit’s security code (factory set to 845464) then click “OK”.
Step 4.	The program will then read and display the K-1900-6/7-IP phone’s IP and programming settings.
Step 5.	After adjusting the IP and phones settings, click the “Apply” button to send the programming commands to the connected unit.

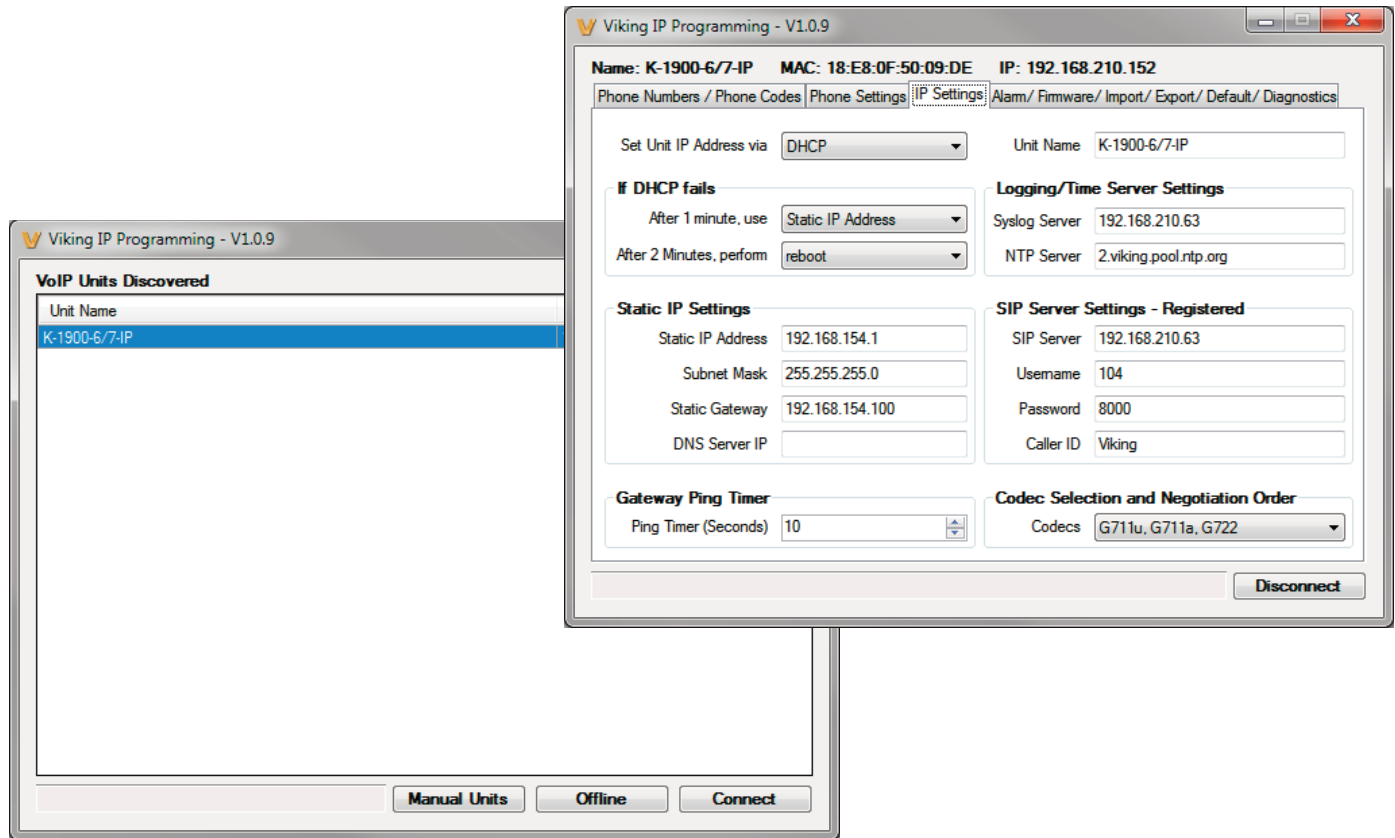

C. Manually Resetting the Security Code to Enter Programming

Step 1.	Power down the K-1900-6/7-IP phone by disconnecting the LAN Cable (RJ45 plug).
Step 2.	Take the handset offhook, then reconnect the LAN Cable (RJ45 plug).
Step 3.	8-12 seconds after connecting the LAN Cable you should hear 2 beeps in the handset. Go back on-hook within 6 seconds and you should hear 2 more beeps.
Step 4.	The security code is now reset to 845464 (factory default).
Step 5.	You can now enter programming by following the steps in section B above.

D. Manually Resetting All Network Parameters to Factory Default

Step 1.	Power down the K-1900-6/7-IP phone by disconnecting the LAN Cable (RJ45 plug).
Step 2.	Take the handset offhook, then reconnect the LAN Cable (RJ45 plug).
Step 3.	8-12 seconds after connecting the LAN Cable you should hear 2 beeps in the handset. 6 seconds later you should hear 4 beeps, go back on-hook within *6 seconds. Unit will reset and 2 beeps will be heard in approximately 7 seconds.
Step 4.	You can now enter programming by following the steps in section B above.

***Note:** if you do not go back on-hook within 6 seconds, the handset will continue to beep until back on-hook. This indicates an error and network parameters will remain unchanged.

Programming Features Index

DESCRIPTION	Section	Page
Connect/Disconnect	1	10
Speed Dial Numbers	2	11
Phone Name	5	13
Mute Alarm Until Next Failure	6	13
Phone Firmware	7	13
IP Firmware	8	13
Import/Export	9	14
Factory Default	10	14
Diagnostics (used to check relay and operation)	11	14
Security code (factory set to 845464)	12	14
Access Code (1-6 digits, blank = disabled, factory set to 123456)	13	14
Loud Ring (Enable, Disable, factory set to Enable)	14	14
Ring Cadence (factory Set to Normal Ring)	15	14
Loud Ring Volume (0-9, 1 - low, 9 - high, 0 = disabled, factory set to 5)	16	14
Relay Mode (Door Strike, Outbound Call, In/Outbound Call, Doorbell, Alarm Mode, factory set to Door Strike)	23	16
Relay Command (1 or 2 digits, factory set to ** and *2) (Relay Mode must be set to Door Strike)	24	16
Relay Time (0.5 - 99 sec, factory set to 5 sec)	25	16
Relay Int/Ext (factory set to Internal)	26	16
Latch Commands (Enabled or Disabled, factory set to Enabled)	29	16
Audio Call Progress (OFF, ON, factory set to ON)	30	17
Audio Detect Level (1-9, 1 = min, 9 = max, factory set to 5, power cycle unit after setting)	31	17
Call Length Time Out (disabled or 1 to 9 min, factory set to 3 min)	32	17
Dial Next # on RNA (Ring No Answer) (disabled, 1 - 9 = number of rings, factory set to 7)	33	17
Dial Next # on Busy (disabled or enabled, factory set to enabled)	34	17

Programming Features

1. Connect/Disconnect

To connect to a **K-1900-6/7-IP** shown in the VoIP Units Discovered window, simply click the unit then click the “Connect” button. The preprogrammed settings should then fill the different tabs. When you are finished making the programming changes, the “Apply” button allows you to program the K-1900-6/7-IP and disconnect from the unit. Closing the PC programming will also automatically disconnect the unit. Click the “Disconnect” button to abandon your changes.

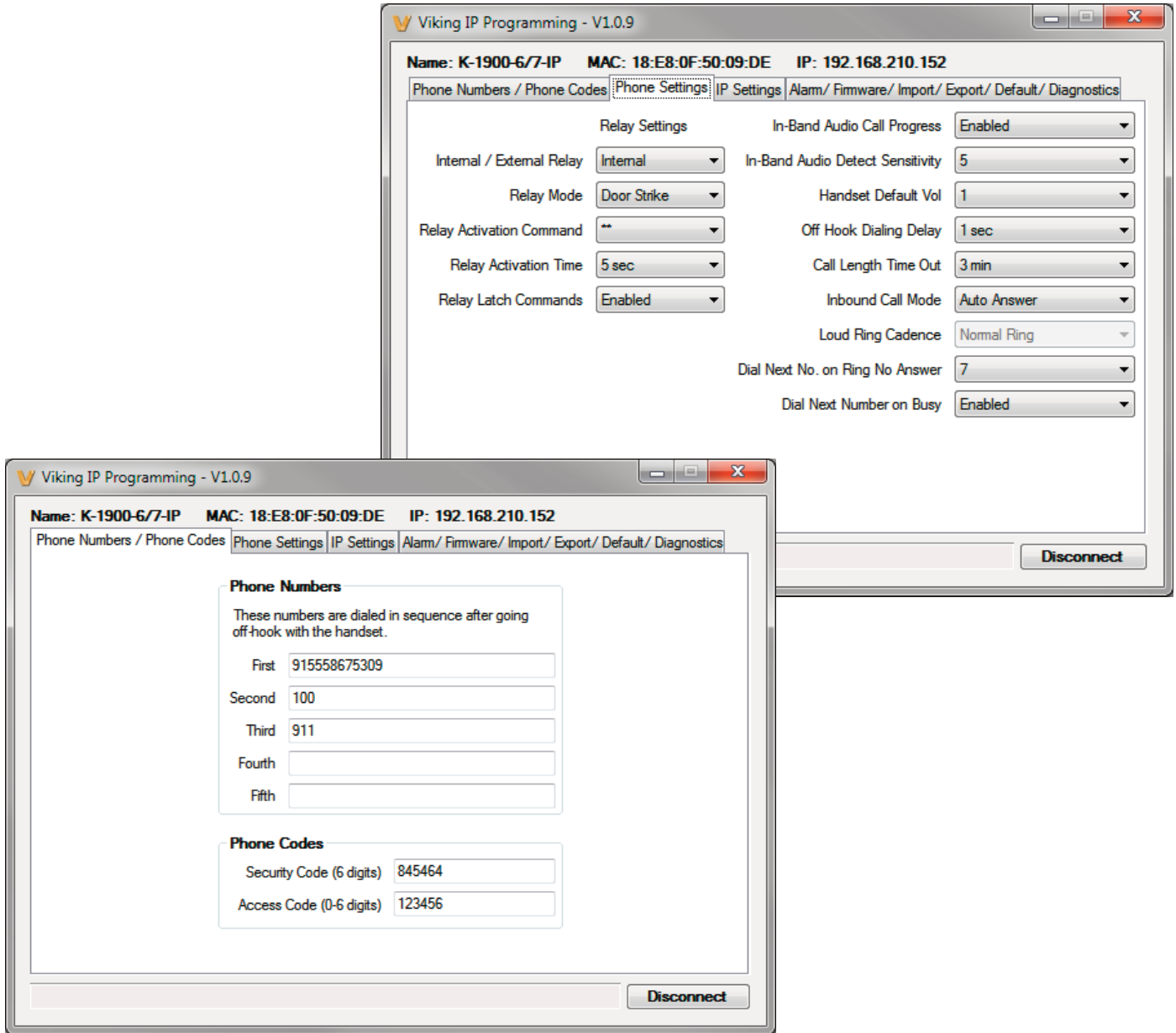

2. Speed Dial Numbers (1-5)

The speed dial number programmed in location 1 is the number that is dialed when the "K-1900-6/7-IP" goes off hook. Additional speed dial numbers will be dialed when there is no answer or a busy signal is detected. The K-1900-6/7-IP phone is factory set with no speed dial numbers programmed.

3. Phone Name

Up to a 32 character phone name can be assigned to the K-1900-6/7-IP being programmed. Often times the building name and entrance location near the unit are used for the name.

4. Mute Current / Next Alarm

A network failure alarm will be indicated by flashing the "SIP Alarm LED" and providing 3 beeps every 30 seconds in the handset of the K-1900-6/7-IP. A network failure indicates the unit is not registered to the SIP server or there is a communication failure with the gateway. The three beeps can be muted by clicking on the "Mute Current / Next Alarm".

5. Phone Firmware

If new K-1900-6/7-IP firmware is available, after opening the programming software a pop window will ask if you would like to update firmware. Another way to update is accomplished by clicking the phone firmware "Update" button. You can then browse to the folder that contains the HEX file for updating the unit's firmware. This method is typically only used when Viking Technical Support has sent you updated firmware.

6. IP Firmware

If new K-1900-6/7-IP firmware is available, after opening the programming software a pop window will ask if you would like to update firmware. Another way to update is accomplished by clicking the IP firmware "Update" button. You can then browse to the folder that contains the PIP file for updating the unit's IP firmware. This method is typically only used when Viking Technical Support has sent you updated IP firmware

7. Import/Export

The Import/Export feature is useful for backing up all the K-1900-6/7-IP's programming or for importing programming when installing multiple units with a majority of the same programming.

8. Factory Default

Clicking on the "Factory Default" button in programming will reset all of the Programming Features back to their factory default settings. **Note:** *This command will not change or reset your IP settings.*

9. Diagnostics

The Diagnostics section in the K-1900-6/7-IP PC Programming can be used to test the functionality of the relay.

10. Security Code

The security code allows the user/installer to program the K-1900-6/7-IP phone. The factory set security code is 845464. It is recommended that the factory set security code be changed.

Note: *The security code must be 6 digits and cannot include a * or a #.*

11. Access Code

The Access Code is used for remotely operating the relays (Doorstrike, Mag-Lock, etc) by calling into the unit with In-bound Call Mode set to "Auto Answer" or by having someone answer the call by lifting the handset. This code provides basic security and only allows operation of the relay. Once the access code is entered, any of the "Remote Access Operation Commands" can be used. The code can be 1 to 6 digits in length and cannot contain a "*" or "#". The access code can be disabled if this basic security is not required. Simply call the K-1900-6/7-IP phone, when someone lifts the handset to answer, the unit will output one beep. You then enter the programmed 1 to 6 digit access code, 2 beeps should be heard. You can now enter any "Remote Access Operation Commands" (see page 19).

12. Loud Ring Volume

The Loud Ring feature can be set to one of three modes:

Disable: In the “Disable” mode the phone will not output a loud ring during an incoming call.

Low: In the “low” mode the phone will output a ring signal out of the earpiece in the ring pattern selected in Loud Ring Cadence. The call can then be answered by taking the handset off hook.

High: In the “High” mode the phone will output a slightly louder, higher pitched ring signal out of the earpiece in the ring pattern selected in Loud Ring Cadence. The call can then be answered by taking the handset off hook.

13. Loud Ring Cadence

When “Loud Ring Volume” on the **K-1900-6/7-IP** is set to “Low” or “High” the Loud Ring cadence can be programmed to one of 4 different cadences:

Normal Ring (single ring, 2 sec on 4 sec off)

Double Ring (double ring, 1 sec on .5 sec off 1 sec on 3.5 sec off)

Short-Short-Long (triple ring, .5 sec on .5 sec off .5 sec on .5 sec off 1 sec on 3 sec off)

Short-Long-Short (triple ring, .5 sec on .5 sec off 1 sec on .5 sec off .5 sec on 3 sec off)

14. Relay Mode

Doorstrike Mode: When programmed for Doorstrike Mode the relay is intended for door strike, maglock or gate control. The relay will momentarily activate for the preprogrammed relay activation time after detecting the correct relay activation command (one or two digit touch tone) from the called party.

Outbound Call Mode: When programmed for Outbound Call Mode the relay will activate continuously for the duration of any outbound call from the Entry phone.

Inbound/Outbound Call Mode: When programmed for Inbound/Outbound Call Mode the relay will activate continuously for the duration of any inbound or outbound call to or from the Entry phone. This mode is useful for turning on IR flood lights, for VoIP phones with cameras, etc.

Doorbell Mode: When programmed for Doorbell Mode the relay will momentarily activate the relay for the preprogrammed relay activation time on any outbound call from the Entry phone. This mode is useful for activating a door chime, etc. When activating door chimes, a 0.5 - 1 second relay activation time is recommended.

Alarm Mode: When programmed in Alarm Mode the relay will activate continuously while the Entry phone is powered and registered to the SIP server. In the event the unit loses power and/or SIP registration the relay will turn off, which can be used to signal an alarm device.

Loud Ring Mode: When programmed for Loud Ring Mode the relay will continuously activate while the ringing extension is called. This mode is useful for activating a Viking model **SL-2** strobe light, etc.

Loud Ring Flash Mode: When programmed for Loud Ring Flash Mode the relay will momentarily turn on and off in a 400ms on/off cadence while the ringing extension is called. This mode is useful for activating a Viking **LPL-1** Remote Visual Indicator, etc.

15. Relay Activation Command

The one or two digit code stored in the Relay Activation Command is the touch tone command that the person being called must enter on their phone in order to momentarily activate the relay to control a doorstrike, mag-lock, gate controller, or other device. The code can contain 0 - 9, # or *. The code cannot match a relay latching or toggle command (11, 10, 1#). The code must be entered while the remote phone is communicating with the Entry phone. The Entry phone determines which direction the touch tone is coming from and only responds to touch tones from the called phone. The factory setting is **.

16. Relay Activation Time

The value stored in the Relay Activation Time is the amount of time the relay will be energized after a correct momentary touch tone command is entered. This number can range from 0.5 to 99 seconds. The factory setting is 5 seconds.

17. Relay Internal / External

With the relay set to “Internal” the **K-1900-6/7-IP** will activate its on board relay for door strike / gate control. The relay should be set to “External” for higher security installations when using a remote Viking model **RC-4A** relay controller to activate the door strike / gate controller (see page 6).

18. Relay Latch Commands (Enable / Disable Relay Latching Commands)

When programmed to “Enable” (factory default) the Remote Access Operation Commands to Un-Latch, Latch or toggle the relay are enabled.

When programmed to “Disable” the Remote Access Operation Commands to Un-Latch, Latch or toggle the relay are disabled. Disabling the Latch commands can be useful in applications where you want to eliminate the possibility of inadvertently entering a latch command leaving a gate open/closed, etc.

19. In-Band Audio Call Progress

The In-Band Audio Call Progress Detection can be set to enabled or disabled. In-Band Audio Call Progress detection should be enabled in applications where you are making an outbound call through your VoIP phone system and are relying on In-Band analog audio for ringback or busy detection. The factory default is: disabled.

20. In-Band Audio Detection Sensitivity

The In-Band Audio Detection level (Sensitivity) can be set from 1 to 9 (1 = minimum setting, 9 = the highest sensitivity, factory set to 5). Increasing or decreasing the sensitivity may be required in applications where you are making an outbound call through your VoIP phone system and are relying on In-Band analog audio detection.

21. Call Length Time Out

This feature selects the maximum length of time that calls can be connected. Programmable in increments of 1 minute up to a maximum of 9 minutes or disabled. With the call length disabled, the **K-1900-6/7-IP** phone must rely on a call ended signal, busy signal, silence or return to dial tone to hang-up.

Note: *The factory default is 3 minutes.*

22. Dial Next Number on Ring No Answer

If enabled and a ring-no-answer is detected, the **K-1900-6/7-IP** phone will dial the “Roll Over” speed dial number.

Note: *Factory set to redial if not answered after 7 rings.*

23. Dial Next Number on Busy

If enabled and a busy is detected, the **K-1900-6/7-IP** phone will dial the “Roll Over” speed dial number. **Notes:** *This feature is enabled in the factory default setting. If the busy signal is interrupted with a promotional message, contact your central office to have it removed.*

Operation

A. Making a Call

When the handset is taken off-hook, the **K-1900-6/7-IP** immediately dials the pre-programmed telephone number stored in the Speed Dial Number location 1. In the event the line is busy or there is a ring-no-answer, the unit can be programmed to call up to 4 additional roll over numbers.

When the call is answered, relay activation commands can be entered or the # key can be used to force the phone to hang-up.

After communication is established, enter the 1 or 2 digit relay activation command (factory set to “**”) to momentarily activate the entry phone (door strike) relay. Two beeps will be heard confirming that the relay has been activated. If you require the relay to remain on continuously (ie: a truck delivery), enter Touch Tones “11” to continuously activate the relay. A double beep will indicate that the relay is latched on. When the visitor calls in again (ie: they are finished unloading the truck), enter Touch Tones “10” to deactivate the relay. A single beep will indicate the relay is latched off.

B. Remote Access Operation Commands

The following commands can be entered after answering an inbound call from the entry phone, calling into the entry phone and the unit auto answers or someone answers the call by lifting the handset. After the entry phone auto answers the call, one or two beeps will be heard. If the access code has been disabled (two beeps heard), you can now enter the Remote Access Operation Commands below. If an Access code has been programmed (one beep heard), enter the Access code digits. With the correct code entered, two beeps will be heard and you can now enter the Remote Access Operation Commands below. The relay must be set to “Door Strike” Mode to be controlled by these commands.

Feature	Touch Tone Command	Description
Momentarily Activate Relay	** or — —	Momentarily activate relay (1 or 2 digits, factory set to **).
Latch Relay	11	Latch* (continuously activate) relay.
Un-Latch Relay	10	Un-latch* (deactivate) relay.
Toggle Relay	1#	Toggle relay from last position.

* **Note:** Latching commands must be enabled in programming.

Troubleshooting

If the unit cannot register with the SIP server, three beeps will be heard every 30 seconds until communication is restored. This alerts a potential user of a problem with the device that will prevent a phone call from being made.

You may silence the error beeps, per instance, by clicking the “Mute Current / Next Alarm” button in the Viking IP Programming Software (see section **A** on page 7). The error beeps automatically re-enable once the unit is registered, to alert of any new problems that arise.

Surface or Pedestal Mount Viking Products While Maintaining Weather and Vandal Resistance

The **VE-3x5**, **VE-5x5**, **VE-6x7** and **VE-5x10** add vandal and weather resistance, as well as versatility to many Viking products. The **VE-Series** backboxes are available in black fine texture powder painted steel or marine grade 316 stainless steel. The weather resistant boxes are designed to be surface mounted to a wall, post, single gang box, or a **VE-GNP** gooseneck pedestal. **Note:** The **VE-3x5** is not compatible with the **VE-GNP** pedestals and is not available in stainless steel.



The **VE-GNP** gooseneck pedestals are designed to be used with the **VE-5x5**, **VE-6x7** and **VE-5x10** backboxes and are ideal for drive up communications. **Note:** The **VE-3x5** is not compatible with the **VE-GNP** pedestals.



The **VE-PNL**'s are **VE-Series** backboxes with a blank aluminum panel. The user can customize the clear-coated aluminum panel to mount an **PRX-1** card reader, **PRX-2** keypad or switch. The kits come complete with box, gasket, panel and screws. Model numbers that end with "SS" are stainless steel version. **Note:** The use of magnets to mount the **VE-Series** enclosure to a metal surface can affect the operation of the enclosed product.

Caution: Handsfree phones are not suitable for noisy applications (see "Important" on page 2).

For more information on Viking Surface Mount Boxes and Pedestals, see **DOD# 424**.

Add Panel Lighting to Your Viking VoIP Entry Phone

The **VE-LIGHT** kit adds bright LED illumination to any VoIP entry phone that is housed in a Viking **VE-5x5**, **VE-6x7** or **VE-5x10** enclosure.

The stainless steel bracket is easily mounted using existing holes and hardware. Two bright white LEDs are used as the light source, so there are no filaments to break or bulbs to burn out.

12 VDC power adapter included. Any power source between 12 and 24 volts, AC or DC can be used to supply the **VE-LIGHT** with power.

For more information, See **DOD# 428**.

VE-LIGHT shown right with Viking E-30 and VE-5x5 (not included)



Control Relay Contacts Across a Local Area Network

The **RC-4A** Network Enabled Relay Controller provides networked control of four relays via an easy-to-use web interface. The same interface can be used to check the status of four contact closure inputs. Relays can be toggled on or off, or user-programmed timed closures can be activated.

The **RC-4A** can be configured to work as a remote relay for Viking VoIP series entry phones, controlling door strikes and gates when a remote relay is required for security reasons. It can also be programmed to send an email or text message in response to a change in one or more of the sensor inputs. Two **RC-4A's** can be set up so that activity on a sensor input of one unit will automatically send a message across the network to activate one of the relays on the other unit. Two levels of user access permit selected users to have full operational and programming rights while others have operational control but not programming capability.



For more info, see **DOD# 585**

Vandal Resistant VoIP Phone with Auto Dialer, Keypad and Entry System

The **K-1900-8-IP VoIP** panel phone can either auto-dial a phone number each time the handset is lifted, be used as a multi-number auto-dialer, or be used as a standard manual dial phone. The **K-1900-8-IP** VoIP phone is designed to provide quick and reliable hands-free communication for SIP VoIP phone systems with PoE. The unit can be programmed from any PC on the same LAN or remotely using a Static IP Address. The **K-1700-8-IP** phone can dial up to 250 programmable numbers and another 250 rollover numbers.

When a call initiated by the **K-1900-8-IP** phone is answered by an apartment or business tenant, a built-in contact closure may be activated to control an electric gate or door strike. Up to 1,000 keyless entry codes may be programmed, providing tenants with keyless entry. A 26 Bit Wiegand input is provided for adding an optional proximity card reader with capacity to program up to 1,000 card numbers. Keyless entry codes and card numbers can be programmed to only allow access at specific times and/or day of the week. A request for exit (REX) input is included for easy exiting. The **K-1900-8-IP** also has automatic event logging allowing you to review the time and date of the call, which door was open/closed, what keyless entry code or proximity card was used, request for exit usage and whether it was an inbound or outbound call.

The **K-1900-8-IP-EWP** shares all of the features of the **K-1900-8-IP** in addition to Enhanced Weather Protection (EWP) for outdoor installations where the unit is exposed to precipitation or condensation. EWP products feature foam rubber gaskets and boots, sealed connections, gel-filled butt connectors, as well as urethane or thermal plastic potted circuit boards. For more information on EWP, see **DOD# 859**.



For more info, see **DOD# 361**

Warranty

IF YOU HAVE A PROBLEM WITH A VIKING PRODUCT, CONTACT: VIKING TECHNICAL SUPPORT AT (715) 386-8666

Our Technical Support Department is available for assistance Monday through Friday 8:00am to 5:00pm central time. So that we can give you better service, before you call please:

1. Know the model number, the serial number and what software version you have (see serial label).
2. Have your Product Manual in front of you.
3. It is best if you are on site.

RETURNING PRODUCT FOR REPAIR

The following procedure is for equipment that needs repair:

1. Customer must contact Viking's Technical Support Department at 715-386-8666 to obtain a Return Authorization (RA) number. The customer MUST have a complete description of the problem, with all pertinent information regarding the defect, such as options set, conditions, symptoms, methods to duplicate problem, frequency of failure, etc.
2. Packing: Return equipment in original box or in proper packing so that damage will not occur while in transit. Static sensitive equipment such as a circuit board should be in an anti-static bag, sandwiched between foam and individually boxed. All equipment should be wrapped to avoid packing material lodging in or sticking to the equipment. Include ALL parts of the equipment. C.O.D. or freight collect shipments cannot be accepted. Ship cartons prepaid to: **Viking Electronics, 1531 Industrial Street, Hudson, WI 54016**
3. Return shipping address: Be sure to include your return shipping address inside the box. We cannot ship to a PO Box.
4. RA number on carton: In large printing, write the R.A. number on the outside of each carton being returned.

RETURNING PRODUCT FOR EXCHANGE

The following procedure is for equipment that has failed out-of-box (within 10 days of purchase):

1. Customer must contact Viking's Technical Support at 715-386-8666 to determine possible causes for the problem. The customer MUST be able to step through recommended tests for diagnosis.
2. If the Technical Support Product Specialist determines that the equipment is defective based on the customer's input and troubleshooting, a Return Authorization (R.A.) number will be issued. This number is valid for fourteen (14) calendar days from the date of issue.
3. After obtaining the R.A. number, return the approved equipment to your distributor, referencing the R.A. number. Your distributor will then replace the Viking product using the same R.A. number.
4. **The distributor will NOT exchange this product without first obtaining the R.A. number from you. If you haven't followed the steps listed in 1, 2 and 3, be aware that you will have to pay a restocking charge.**

TWO YEAR LIMITED WARRANTY

Viking warrants its products to be free from defects in the workmanship or materials, under normal use and service, for a period of two years from the date of purchase from any authorized Viking distributor. If at any time during the warranty period, the product is deemed defective or malfunctions, return the product to Viking Electronics, Inc., 1531 Industrial Street, Hudson, WI., 54016. Customer must contact Viking's Technical Support Department at 715-386-8666 to obtain a Return Authorization (R.A.) number.

This warranty does not cover any damage to the product due to lightning, over voltage, under voltage, accident, misuse, abuse, negligence or any damage caused by use of the product by the purchaser or others. This warranty does not cover non-EWP products that have been exposed to wet or corrosive environments. This warranty does not cover stainless steel surfaces that have not been properly maintained.

NO OTHER WARRANTIES. VIKING MAKES NO WARRANTIES RELATING TO ITS PRODUCTS OTHER THAN AS DESCRIBED ABOVE AND DISCLAIMS ANY EXPRESS OR IMPLIED WARRANTIES OR MERCHANTABILITY OR FITNESS FOR ANY PARTICULAR PURPOSE.

EXCLUSION OF CONSEQUENTIAL DAMAGES. VIKING SHALL NOT, UNDER ANY CIRCUMSTANCES, BE LIABLE TO PURCHASER, OR ANY OTHER PARTY, FOR CONSEQUENTIAL, INCIDENTAL, SPECIAL OR EXEMPLARY DAMAGES ARISING OUT OF OR RELATED TO THE SALE OR USE OF THE PRODUCT SOLD HEREUNDER.

EXCLUSIVE REMEDY AND LIMITATION OF LIABILITY. WHETHER IN AN ACTION BASED ON CONTRACT, TORT (INCLUDING NEGLIGENCE OR STRICT LIABILITY) OR ANY OTHER LEGAL THEORY, ANY LIABILITY OF VIKING SHALL BE LIMITED TO REPAIR OR REPLACEMENT OF THE PRODUCT, OR AT VIKING'S OPTION, REFUND OF THE PURCHASE PRICE AS THE EXCLUSIVE REMEDY AND ANY LIABILITY OF VIKING SHALL BE SO LIMITED.

IT IS EXPRESSLY UNDERSTOOD AND AGREED THAT EACH AND EVERY PROVISION OF THIS AGREEMENT WHICH PROVIDES FOR DISCLAIMER OF WARRANTIES, EXCLUSION OF CONSEQUENTIAL DAMAGES, AND EXCLUSIVE REMEDY AND LIMITATION OF LIABILITY, ARE SEVERABLE FROM ANY OTHER PROVISION AND EACH PROVISION IS A SEPARABLE AND INDEPENDENT ELEMENT OF RISK ALLOCATION AND IS INTENDED TO BE ENFORCED AS SUCH.

If trouble is experienced with the **K-1900-6/7-IP** phone, for repair or warranty information, please contact:

Viking Electronics, Inc., 1531 Industrial Street, Hudson, WI 54016 (715) 386-8666

WHEN PROGRAMMING EMERGENCY NUMBERS AND (OR) MAKING TEST CALLS TO EMERGENCY NUMBERS:

Remain on the line and briefly explain to the dispatcher the reason for the call. Perform such tests in off-peak hours, such as early morning or late evenings.

PART 15 LIMITATIONS

This equipment has been tested and found to comply with the limits for a Class A digital device, pursuant to Part 15 of the FCC Rules. These limits are designed to provide reasonable protection against harmful interference when the equipment is operated in a commercial environment. This equipment generates, uses, and can radiate radio frequency energy and, if not installed and used in accordance with the instruction manual, may cause harmful interference to radio communications. Operation of this equipment in a residential area is likely to cause harmful interference in which case the user will be required to correct the interference at his own expense.

Product Support: (715) 386-8666

Due to the dynamic nature of the product design, the information contained in this document is subject to change without notice. Viking Electronics, and its affiliates and/or subsidiaries assume no responsibility for errors and omissions contained in this information. Revisions of this document or new editions of it may be issued to incorporate such changes.