

## Visit installer's guide

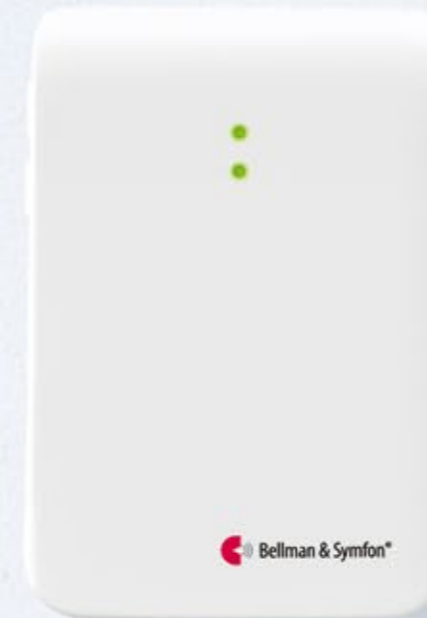



# All you need to know about Visit.



## Transmitters

Door transmitter	5
Push button transmitter	13
Telephone transmitters	17
Baby monitor	25
Smoke alarms	29
CO alarm	39

## Receivers

Flash receiver	43
Portable receiver	47
Pager receiver	51
Wrist receiver	55
Alarm clock receiver	59

## Accessories

Magnetic mounting kit	34
Pager charger	63
Mobile phone sensor	65
Bed shaker	67
Flash receiver bracket	68
Magnetic switch	69
Contact mat	69
External microphone	70
External trigger cable	70

# System overview

## Reliable and flexible

The Visit system is highly flexible and can easily be configured to cater for your client's specific home environment and lifestyle.

It offers doorbell and phone detection, baby monitoring and fire protection that meets the highest standards.



**1 Door transmitter**  
Monitors the doorbell



**2 Smoke alarm**  
Detects smoke and fire



**3 Baby monitor**  
Monitors your little one



**4 Telephone transmitter**  
Monitors phones & tablets

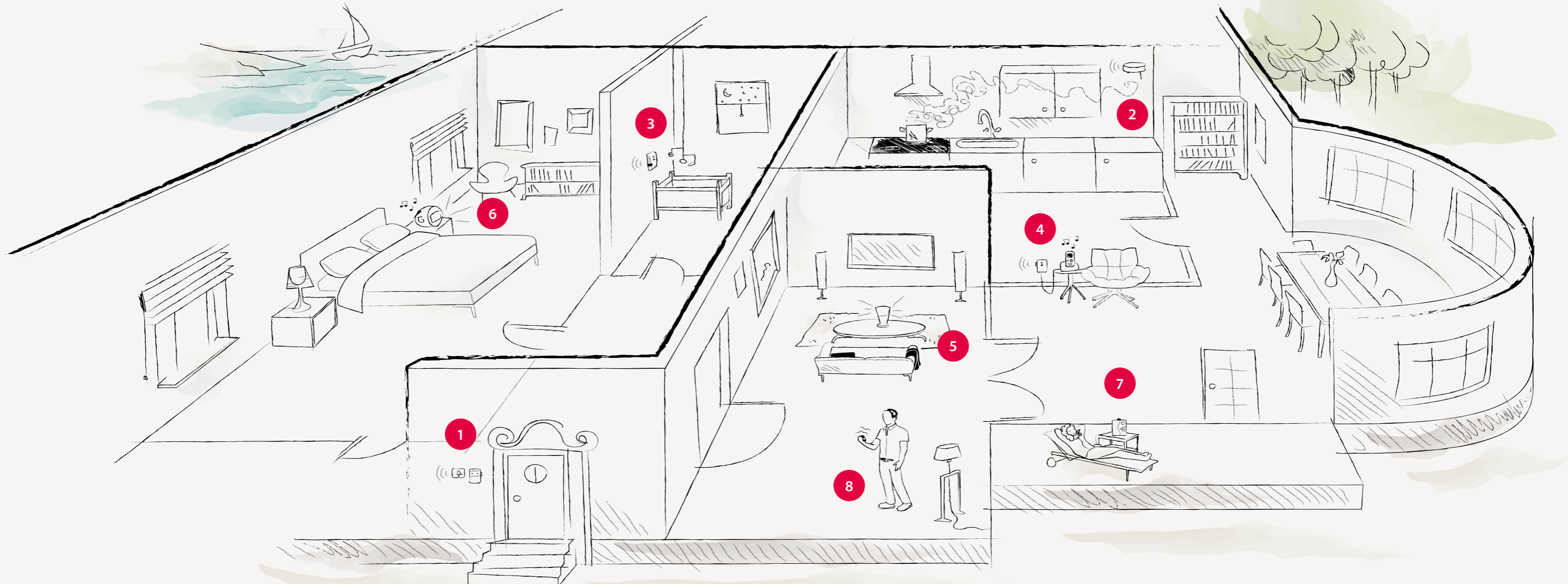

**5 Flash receiver**  
Alerts with bright lights



**6 Alarm clock**  
Uses sound, light & vibrations



**7 Portable receiver**  
Alerts with sound and light



**8 Pager receiver**  
Alerts with vibrations



QR CODE

### Easy access to support material

Use the product QR codes with your mobile phone or tablet to get web access to detailed product information, images and installation movies.



BE1411

# Visit door transmitter

## Buttons and connections

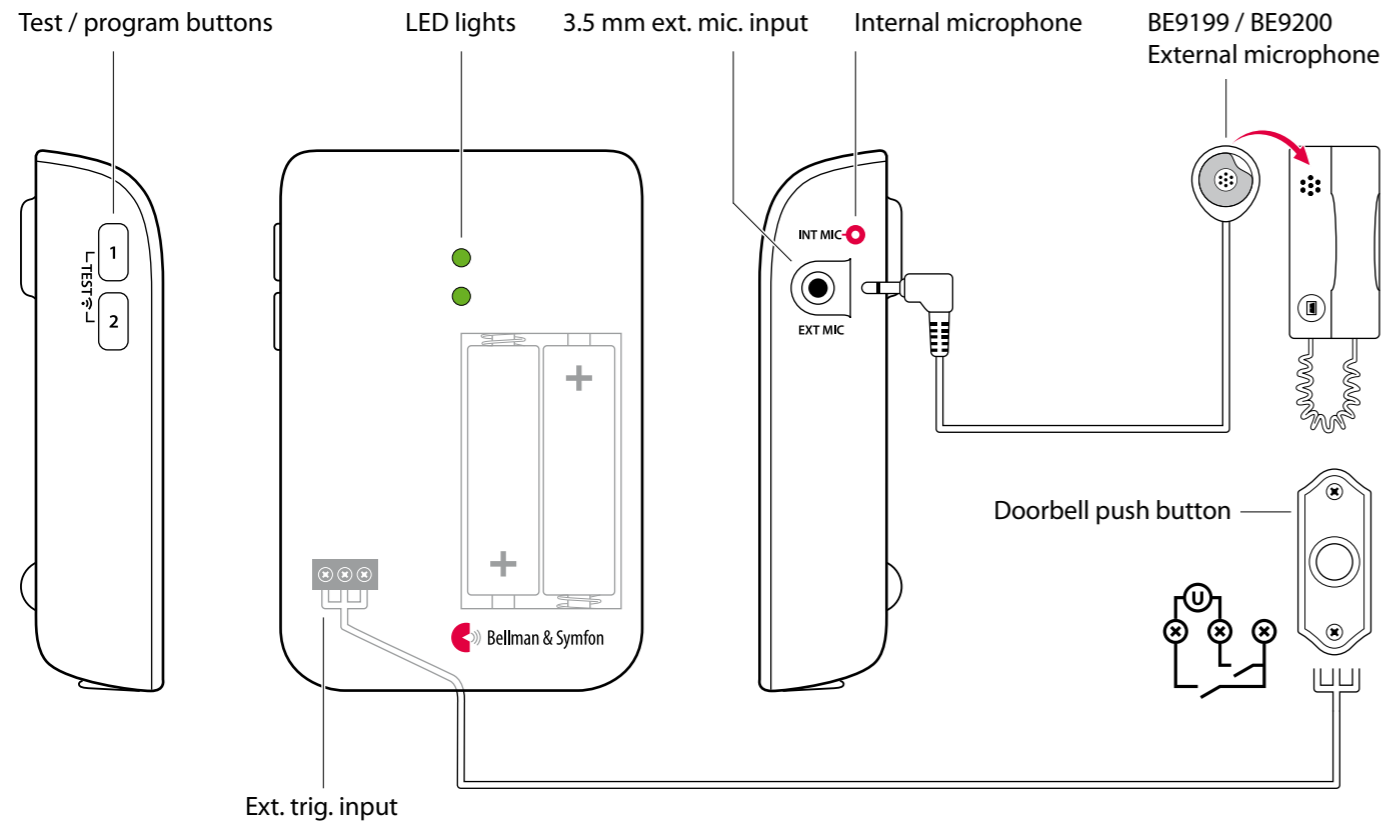

## Technical specifications

### In the box

- BE1411 Visit door transmitter
- 2 × 1.5 V AA (LR6) lithium or alkaline batteries
- Velcro for wall mounting
- Screw and wall plug

### Power and battery

- Battery power  
2 × 1.5 V AA lithium or alkaline type batteries
- Power consumption  
Active < 70 mA  
Idle position < 15 µA
- Operation time  
Alkaline batteries ~ 5 years  
Lithium batteries ~ 10 years

### Dimensions and weight

- Height: 100 mm, 4.0"
- Width: 65 mm, 2.6"
- Depth: 27 mm, 1.1"
- Weight: 120 g, 4.2 oz. incl. batteries

### Activation

- The test buttons and the int. mic.
- The electromagnetic detector
- The external microphone accessory
- The existing doorbell connected to the external trigger input

### Inputs

- 3.5 mm external microphone input
- External trigger input

### Environment

- For indoor use only  
Operating temperature  
0° to 35° C, 59° to 95° F
- Relative humidity  
15% to 90%, non-condensing

### Frequency and coverage

- Frequency: 314.91 MHz, 433.92 MHz or 868.30 MHz, depending on region
- Coverage: 50 - 250 m, 55 - 273 yd. depending on the radio frequency and the building's characteristics

### Accessories

- The following accessories are available:
- BE9199 External microphone 2.5 m
  - BE9200 External microphone 0.75 m

## Installation – single sound source

### Using the transmitter's internal microphone

- Pull the battery tab to start the transmitter.  
Clean the wall with the wet wipe and remove the protective film from the Velcro.
- Mount the door transmitter to the left of the doorbell's sound source, as close as possible.  
You can also use the supplied screw and plug.

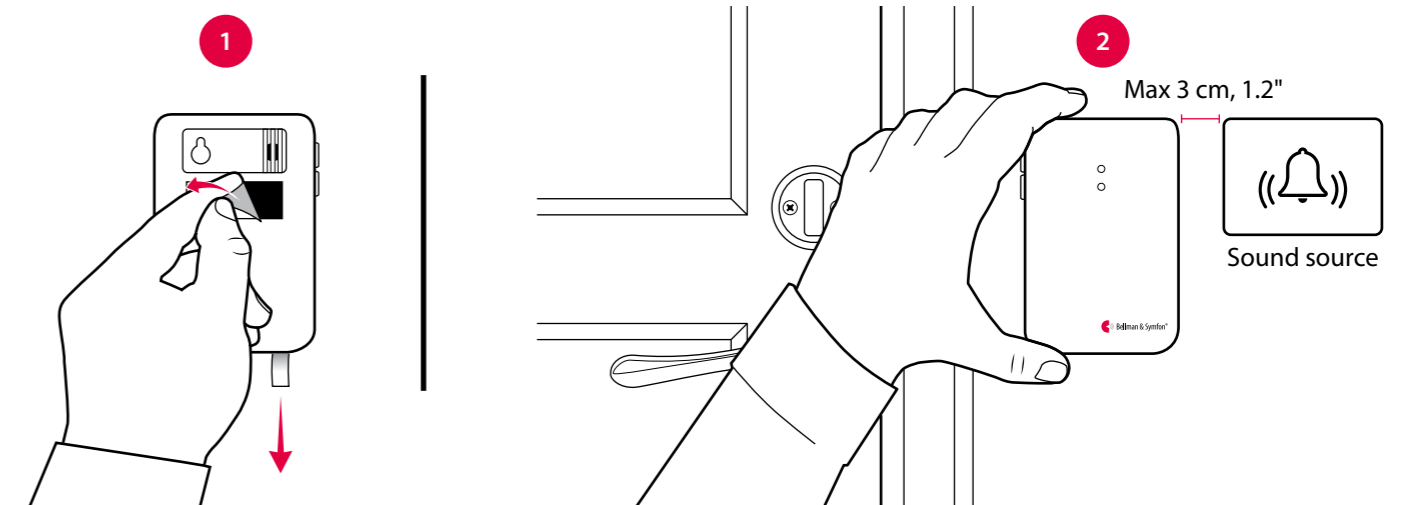

## Alternative installation – single sound source

### Using the external microphone accessory

- Connect the external microphone (sold separately) to the transmitter.  
Remove the protective film and attach it to the intercom's speaker.
  - Pull the battery tab to start the transmitter. Remove the protective film from the Velcro and mount the transmitter on the wall.
  - Within 2 min, press the lower button 10 times to turn off the internal microphone. The LEDs will blink 3 times in red to confirm.
- Note:** If you exceed 2 minutes, you need to restart the transmitter by removing the batteries and putting them back in again.

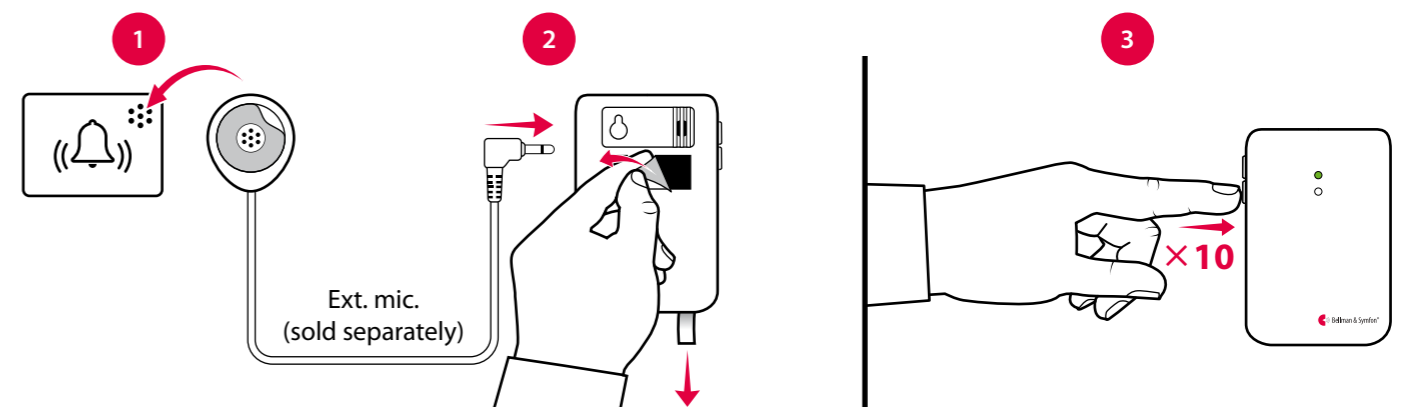

## Turning the internal microphone back on

Restart the transmitter by removing the batteries and putting them back in. Within 2 minutes, press the lower button 10 times to turn the internal microphone back on. The LEDs will blink 3 times in green to confirm.

# Visit door transmitter

## Installation – intercom and electronic doorbell

- 1 Remove the protective film from the external microphone (sold separately) and attach it to the intercom's speaker. Connect it to the door transmitter.
- 2 Pull the battery tab to start the transmitter. Clean the wall with the wet wipe and remove the protective film from the Velcro.
- 3 Mount the door transmitter to the left of the doorbell's sound source, as close as possible.

**Note:** The intercom and doorbell must be at least 25 cm, 10" apart to avoid sound interference.

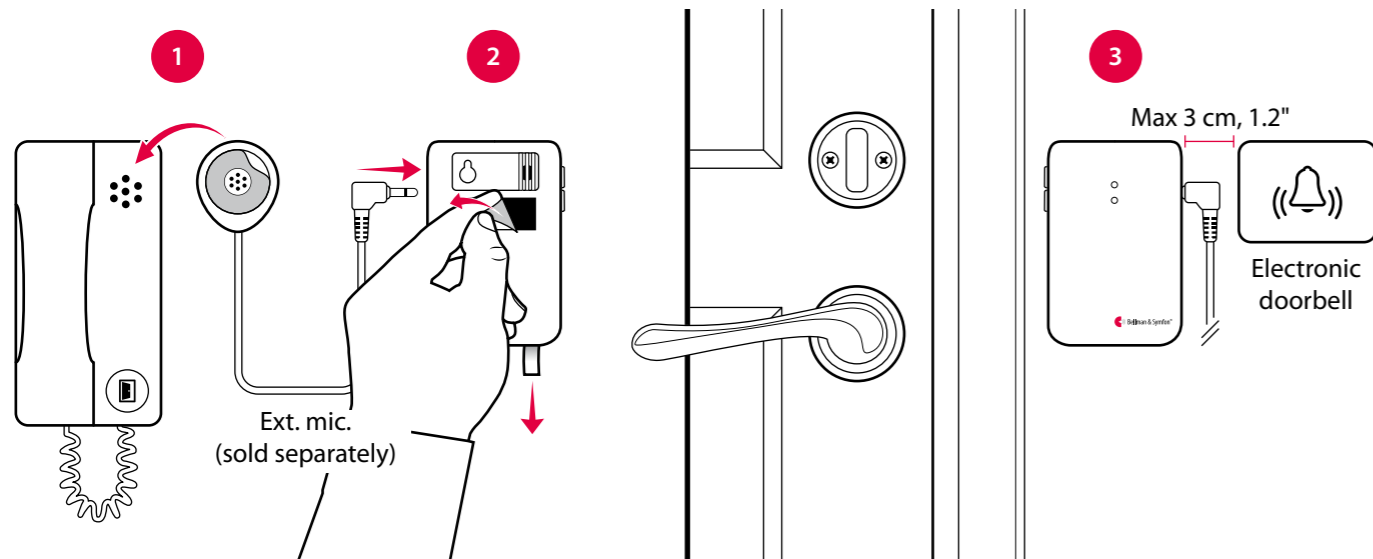

## Installation – intercom and mechanical doorbell

If you have an intercom and a mechanical doorbell, you may need two door transmitters, i.e. one for each sound source.

- 1 Pull the battery tab to start each door transmitter. Clean the wall surfaces with the wet wipe and remove the protective films from the Velcros.
- 2 Mount one of the door transmitters to the left of the doorbell and the other to the left of the intercom's speaker, as close to the sound sources as possible.

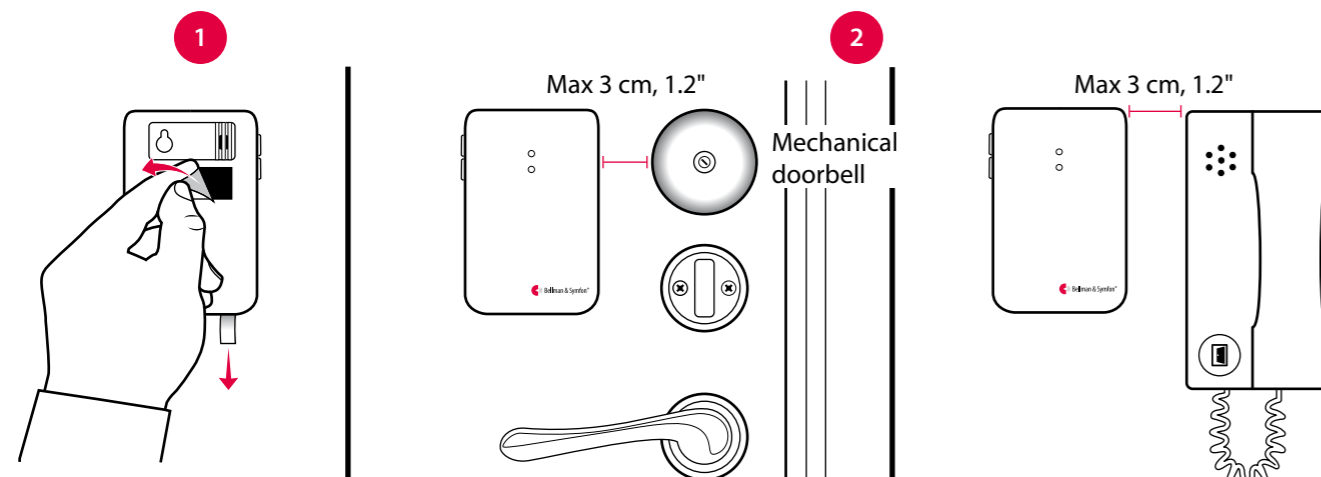

## Installation – hardwiring your doorbell

- 1 Pull the battery tab to start the transmitter. Within 2 min, press the lower button 10 times to turn off the internal microphone. The LEDs will blink 3 times to confirm.
- 2 Remove the front cover to access the screw terminal. There are 3 connection points:
  - Use 1 and 2 to connect an **active** switch, like a relay with current (2–30VDC, polarity independent or 2–24VAC, 5 - 150Hz).
  - Use 2 and 3 to connect a **passive** switch, like a push button.
- 3 Put the front cover back, remove the protective film from the Velcro and mount the door transmitter on the wall.

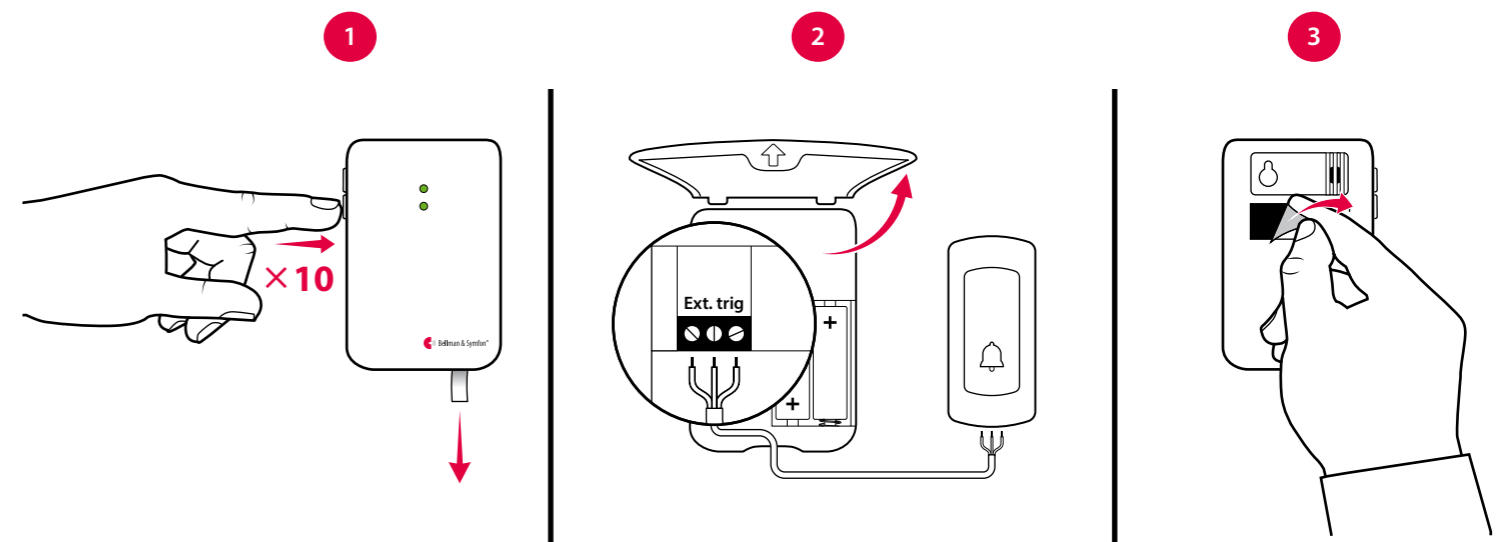
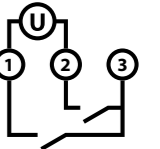

## Using electromagnetic detection

The door transmitter can be set to detect electromagnetic fields emitted by electromechanical doorbells. Here is how it's done:

- **Activating electromagnetic detection:** Move the 4th signal-switch to the up (on position).
- **Deactivating electromagnetic detection:** Move the 4th signal-switch to the down (off position).





# Visit door transmitter

## Optimizing the doorbell detection

The next step is to teach the transmitter to recognize your doorbell.

- 1 Press and hold button 1 until the top LED start to blink. Release it to start the recording.
- 2 **For door buzzers** (with continuous sound): Press and hold the doorbell for at least 8 seconds.  
**For door chimes** (with a "ding-dong" sound): Press the doorbell at least 8 times.
- 3 Press button 1 on the transmitter to stop the recording. If the LED lights up in red, you need to repeat steps 1 and 2. If you have an intercom, use button 2 and follow the steps above to record its sound.

**Note:** To delete all recorded sounds, press and hold button 1 and 2 simultaneously for 5 s. All radio key settings and signal settings are kept intact.

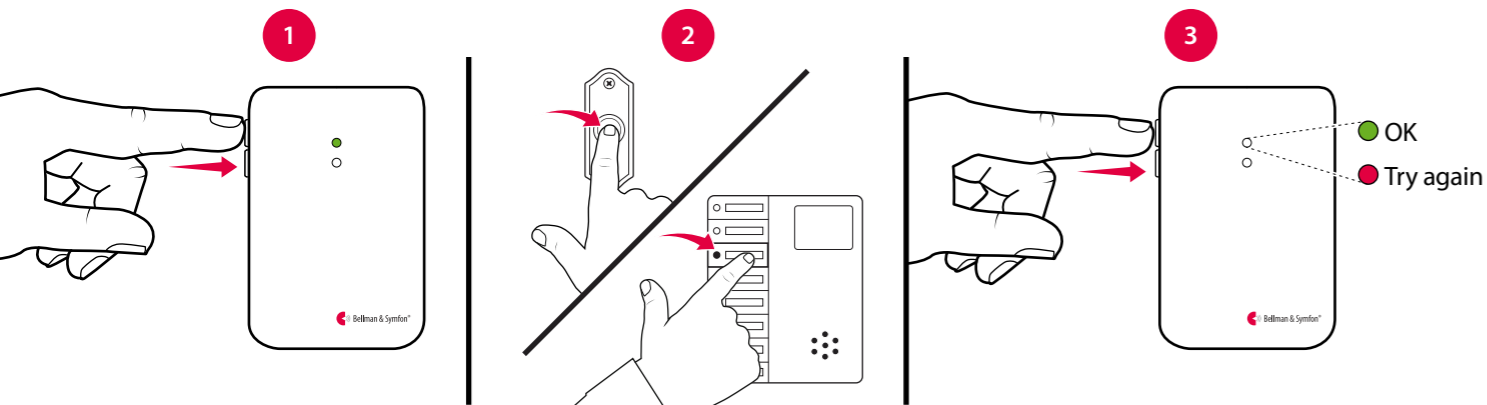

## Testing the connection

### Using the test button

- 1 Press both test buttons simultaneously on the door transmitter. The top LED lights up in green to show that a radio signal is being transmitted.
- 2 The green Visit LED on the receiver lights up to show that the signal was received. In addition, it starts to sound, flash or vibrate depending on the receiver.

**Note:** If you have changed the signal pattern, it will react in accordance with the table on the following spread.

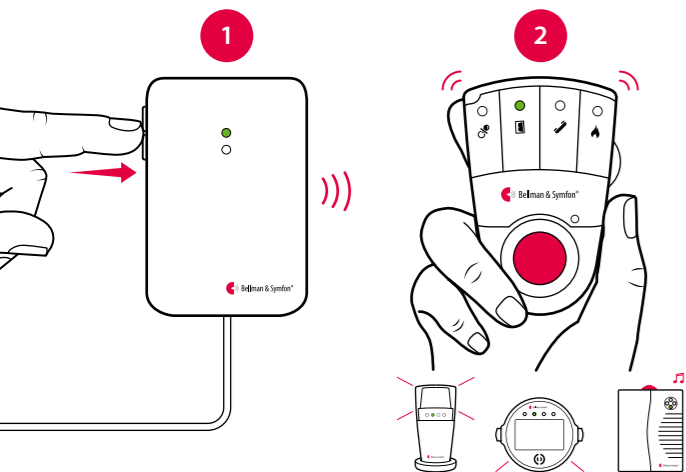

### Using the doorbell or intercom

- 1 Press the button on the doorbell or intercom. The LED on the transmitter lights up in green to show that the sound is detected.
- 2 The green Visit LED on the receiver lights up to show that the radio signal was received. In addition, it starts to sound, flash or vibrate depending on the receiver.

**Note:** If you have changed the signal pattern, it will react in accordance with the table on the following spread.

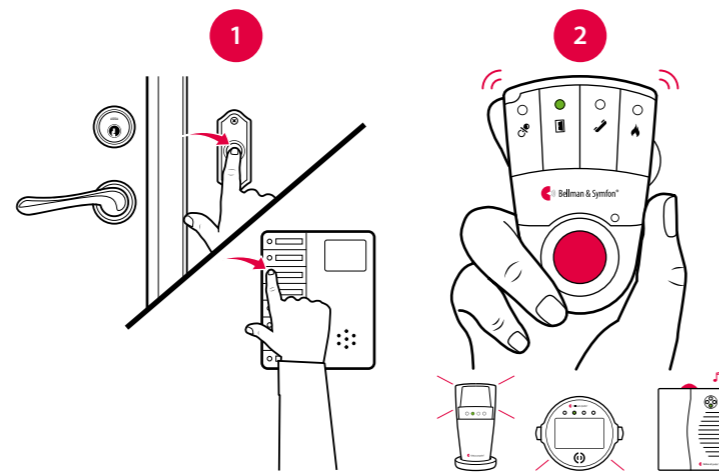

## Default signal pattern

When the door transmitter is activated, the following happens:

- 1 The LED on the transmitter lights up in green to show that it's signalling the receiver.
- 2 The Visit LED on the receiver lights up in green and it starts to sound, flash or vibrate with a certain pace, called signal pattern. The transmitter and the connected accessories determine the signal pattern. The default is as follows:

Transmitter		Receiver signal pattern			
Source	LED	LED	Sound	Vibration	Flash
Internal microphone	Green, top	Green light	1 × door chime, low	Slow ■□□□	Yes
External microphone	Green, bottom	Green blinks	2 × door chime, high	Slow ■□□□	Yes
Connected doorbell	Green, top	3 × green blinks	1 × door chime, high	Slow ■□□□	Yes

## Changing the signal pattern

The transmitter controls the signal pattern. Open the transmitter front cover and move the signal switches according to the table below to change it:



Transmitter		Receiver signal pattern			
Switch	Source	LED	Sound	Vibration	Flash
1 2 3 4	Int. mic. / learned signal 1 / test	Green light	1 × door chime, low	Slow ■□□□	Yes
	Ext. mic. / learned signal 2	Green blink	2 × door chime, high	Slow ■□□□	Yes
	Connected doorbell	3 × green blinks	1 × door chime, high	Slow ■□□□	Yes
1 2 3 4	Int. mic. / learned signal 1 / test	2 × green blinks	2 × door chime low	Slow ■□□□	Yes
	Ext. mic. / learned signal 2	3 × green blinks	1 × door chime, high	Slow ■□□□	Yes
	Connected doorbell	Green blinks	2 × door chime, high	Slow ■□□□	Yes
1 2 3 4	Int. mic. / learned signal 1 / test	3 × green blinks	1 × door chime, high	Slow ■□□□	Yes
	Ext. mic. / learned signal 2	2 × green blinks	2 × door chime, low	Slow ■□□□	Yes
	Connected doorbell	3 × orange blinks	Baby melody	Fast ■■■■■■	Yes
1 2 3 4	Int. mic. / learned signal 1 / test	Green blinks	2 × door chime, high	Slow ■□□□	Yes
	Ext. mic. / learned signal 2	Green light	1 × door chime, low	Slow ■□□□	Yes
	Connected doorbell	Orange blinks	Baby melody	Fast ■■■■■■	Yes
1 2 3 4	Int. mic. / learned signal 1 / test	Green light	1 × door chime, low	Slow ■□□□	Yes
	Ext. mic. / learned signal 2	3 × green blinks	1 × door chime, high	Slow ■□□□	Yes
	Connected doorbell	2 × green blinks	2 × door chime, low	Slow ■□□□	Yes
1 2 3 4	Int. mic. / learned signal 1 / test	Green light	1 × door chime low	Slow ■□□□	Yes
	Ext. mic. / learned signal 2	Green blinks	2 × door chime, high	Slow ■□□□	Yes
	Connected doorbell	Yellow blinks	2 × ring signal, high	Medium ■□■□	Yes
1 2 3 4	Int. mic. / learned signal 1 / test	3 × green blinks	1 × door chime, high	Slow ■□□□	Yes
	Ext. mic. / learned signal 2	Green light	1 × door chime, low	Slow ■□□□	Yes
	Connected doorbell	Red + orange light	Emergency siren	Long ■■■□	Yes
1 2 3 4	Int. mic. / learned signal 1 / test	Green blinks	2 × door chime, high	Slow ■□□□	Yes
	Ext. mic. / learned signal 2	2 × green blinks	2 × door chime, low	Slow ■□□□	Yes
	Connected doorbell	Red blinks	Fire horn	Long ■■□□	Yes

# Visit door transmitter

## Changing the radio key

If your Visit system is activated for no reason, there is probably a nearby system that triggers yours. In order to avoid radio interference, you need to change the radio key on all units. The radio key switches are located under the transmitter cover.

### Here is how you change the radio key:

- 1 Open the transmitter front cover and move any radio key switch to the up (on position) to change the radio key. By default, all radio key switches are positioned down (off).
- 2 Press and hold the test/function button on the receiver until the green and yellow Visit LEDs blink alternately. Release the button.
- 3 Press both test buttons simultaneously on the transmitter within 30 s to send the new radio key.
- 4 All Visit LEDs on the receiver blink 5 times to show that the radio key has been changed. It then returns to normal mode.

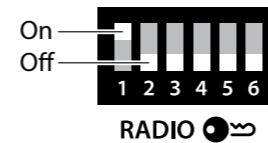

**Note:** All Visit units must be set to the same radio key in order to operate as a group.

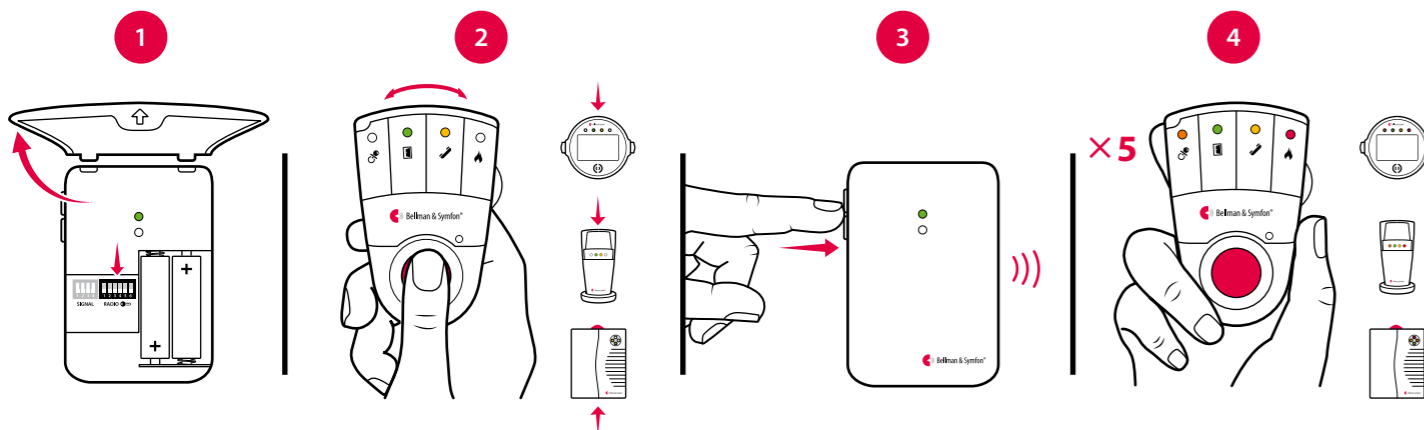

## Troubleshooting

If	Try this
The LEDs blink in orange every minute	<ul style="list-style-type: none"> <li>▪ Replace the batteries. Only use 1.5 V AA (LR6) lithium or alkaline batteries.</li> </ul>
The transmitter LEDs blink in orange every second	<ul style="list-style-type: none"> <li>▪ There are other competing sound sources around the door transmitter. Switch them off or turn them down.</li> <li>▪ Disconnect the external microphone accessory to make sure it is not faulty.</li> </ul>
The transmitter LED lights up when I press the doorbell or intercom – but the receiver is not activated	<ul style="list-style-type: none"> <li>▪ Check the the transmitter batteries and the receiver batteries and connections.</li> <li>▪ Move the receiver closer to the transmitter to make sure it's within radio range.</li> <li>▪ Check that the door transmitter and the receiver are set to the same radio key. For more information, see <b>Changing the radio key</b>.</li> </ul>
The transmitter LED doesn't light up when I ring the doorbell or intercom	<ul style="list-style-type: none"> <li>▪ Ring the doorbell while moving the transmitter closer and further away from the sound source. The ideal distance is less than 3 cm.</li> <li>▪ Program the transmitter to recognize the doorbell sound. See <b>Programming</b>.</li> <li>▪ If the signal varies a lot in strength or tone, change to electromagnetic detection.</li> <li>▪ If the door transmitter is still not activated, press and hold button 1 and 2 simultaneously for 5 s to clear the recorded sounds and repeat the steps above.</li> </ul>
The receiver is activated for no apparent reason	<ul style="list-style-type: none"> <li>▪ There is probably another Visit system installed nearby that triggers your system. Change the radio key on all units, see <b>Changing the radio key</b>.</li> </ul>



# Visit push button transmitter

## Buttons and connections

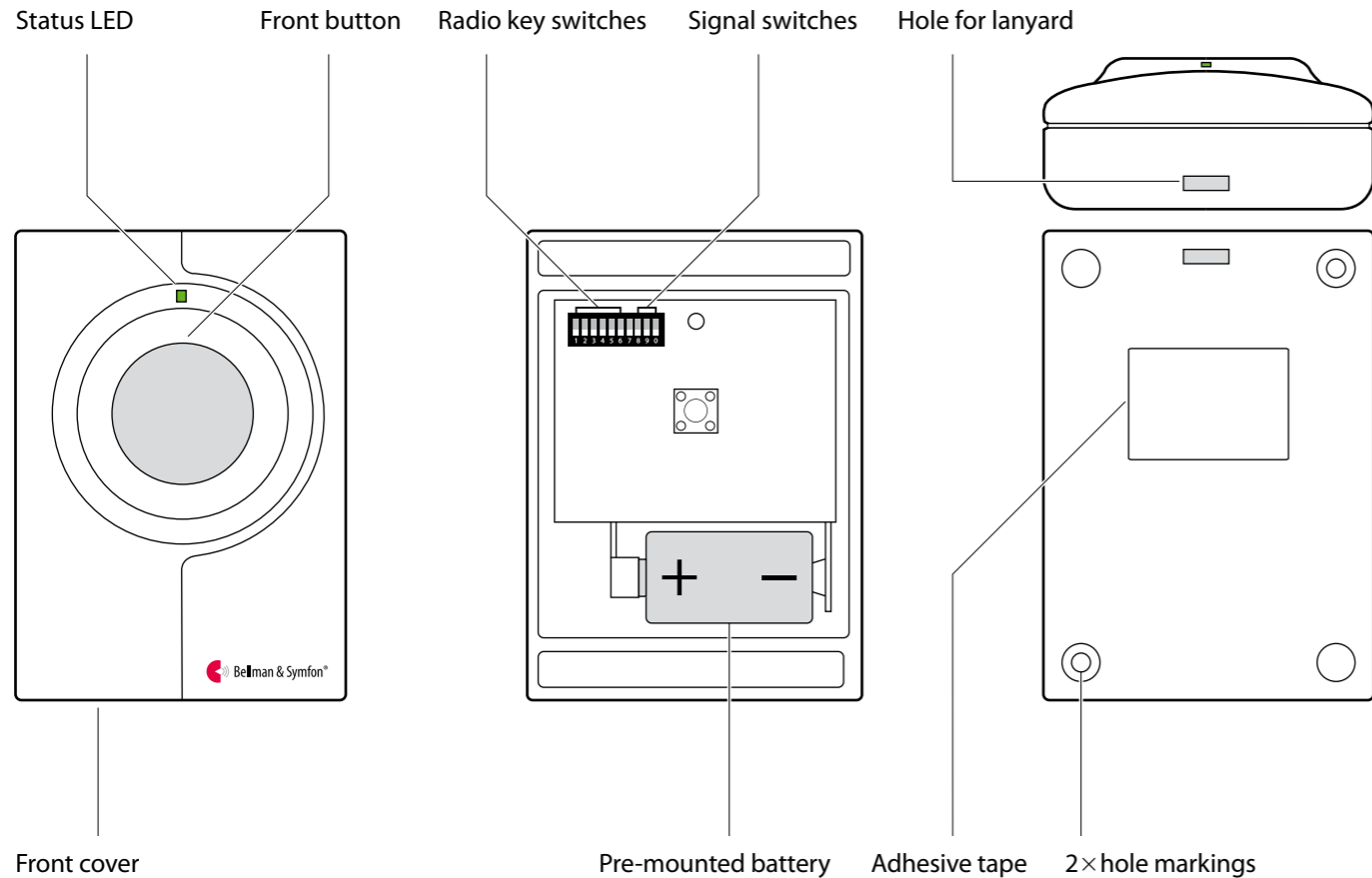

## Technical specifications

### In the box

- BE1420 Visit push button transmitter with pre-mounted alkaline battery
- Lanyard with safety clasp
- Adhesive tape, screws and plugs

### Power and battery

- Battery type
  - 1x6V PX28A alkaline or
  - 1x6V PX28L lithium
- Power consumption
  - Active < 35 mA
  - Idle position < 0.05 µA
- Operation time
  - Alkaline battery ~ 2 years
  - Lithium battery ~ 5 years

### Dimensions and weight

- Height: 66 mm, 2.6"
- Width: 48 mm, 1.9"
- Depth: 23 mm, 0.9"
- Weight: 50 g, 1.8 oz. incl. battery

### Activation

- Via the front button

### Maintenance and cleaning

- Maintenance free
- Clean with a dry cloth
- Do not use household cleaners, aerosol sprays, solvents, alcohol, ammonia or abrasives

### Frequency and coverage

- Frequency
  - 314.91 MHz, 433.92 MHz or 868.30 MHz, depending on the region
- Coverage
  - 50 - 250 m, 55 - 273 yd. depending on the radio frequency and the characteristics of the building

### Environment

- For indoor use and outdoor use in a protected location. Will not withstand water or rain.
- Operating temperature
  - 15° to 35° C, 59° to 95° F
- Relative humidity
  - 5% to 95%, non-condensing

## Using it as a caller button

The transmitter can be worn around your neck and be used as a wireless caller button.

### Here is how you use it:

- Attach the lanyard to the transmitter.
- Hang the transmitter around your neck.

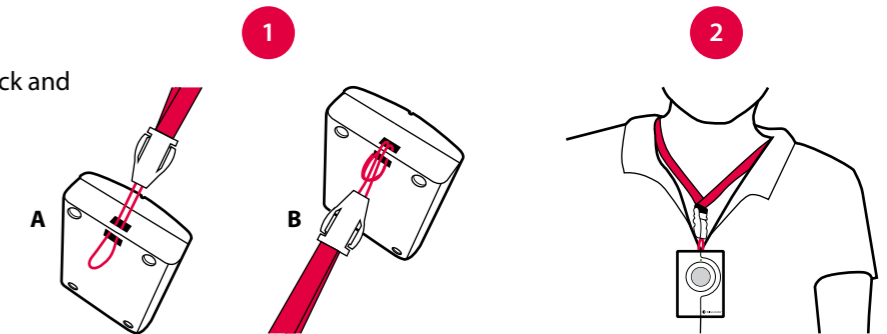

## Using it as a doorbell

The transmitter can also be used as a wireless doorbell. Here is how you set it up:

### Mounting with screws

- Carefully remove the transmitter front cover and make two holes on the markings.
- Fix the unit to the wall using the supplied screws and put the cover back on.

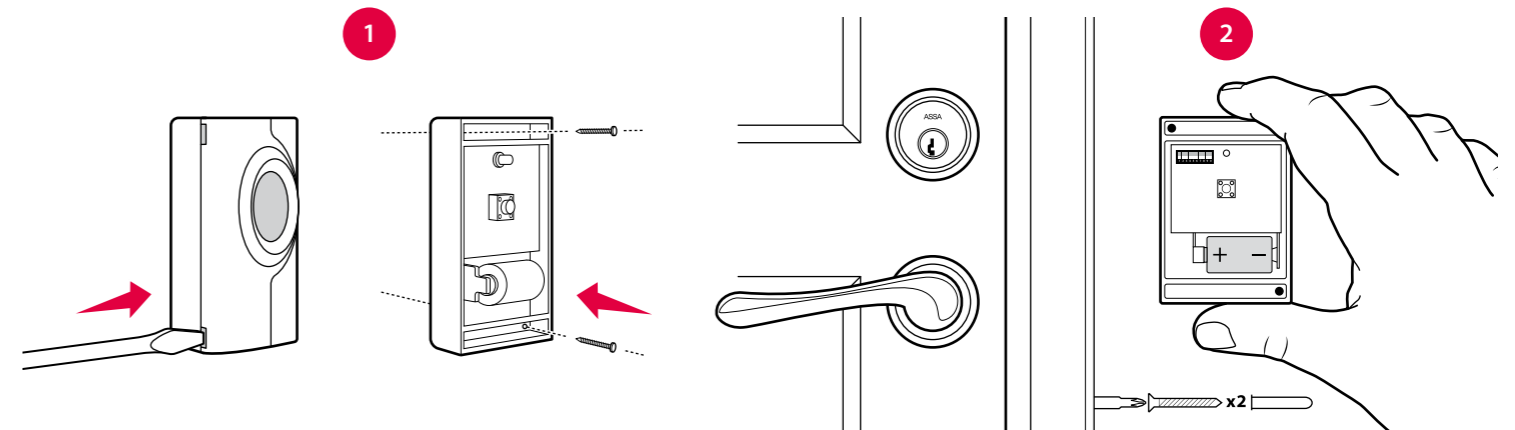

### Mounting with adhesive tape

- Attach the adhesive tape to the back of the transmitter. Clean the wall with the wet wipe and remove the protective film from the tape.
- Mount the unit in a weather protected area by the front door.

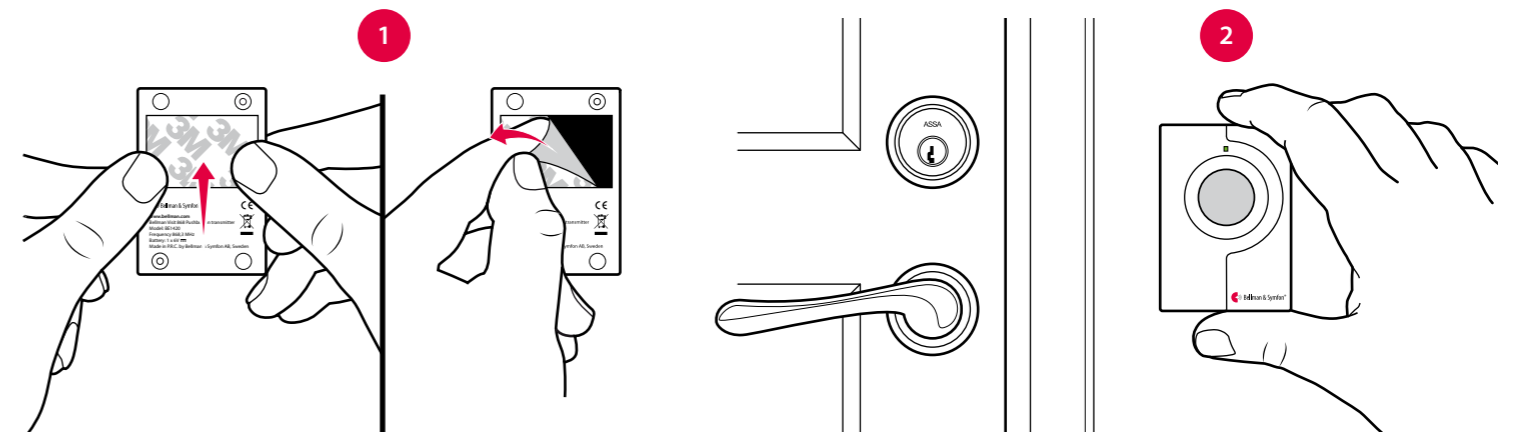





# Visit push button transmitter

## Testing the connection

### Using the front button

- 1 Press the front button on the transmitter. The LED lights up in green to show that a radio signal is being transmitted.
- 2 The green Visit LED on the receiver lights up to show that the signal was received. In addition, it starts to sound, flash or vibrate with a certain pace, called signal pattern.

The transmitter determines the signal pattern and the default is as follows:

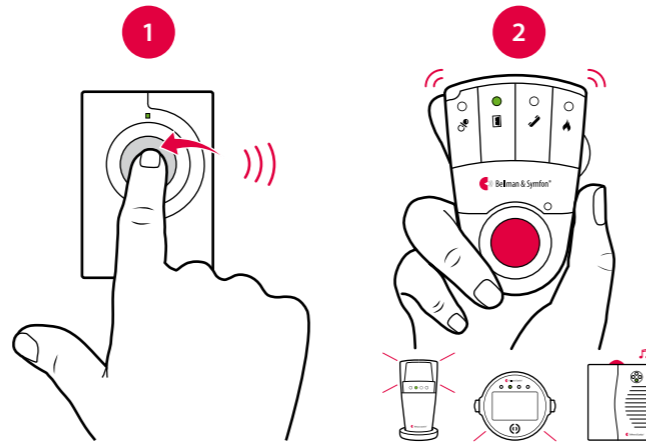

## Default signal pattern

Transmitter	Receiver signal pattern				
LED	LED	Sound	Vibration	Flash	
■ Green light	Green light	1 × door chime, low	Slow ■□□□	Yes	

## Changing the signal pattern

Changing the signal pattern is easy. Just open the transmitter front cover and move signal switches no. 8, 9 and 0 according to the table below:

Transmitter	Receiver signal pattern				
Switch	LED	Sound	Vibration	Flash	
	Green light	1 × door chime, low	Slow ■□□□	Yes	
	2 × green blinks	2 × door chime, low	Slow ■□□□	Yes	
	3 × green blinks	1 × door chime, high	Slow ■□□□	Yes	
	Green blinks	2 × door chime, high	Slow ■□□□	Yes	
	Orange light	Baby melody	Fast ■■■■■■	Yes	
	Orange blinks	Baby melody	Fast ■■■■■■	Yes	
	Yellow light	1 × ring signal, low	Medium ■□■□	Yes	
	Yellow blinks	2 × ring signal, high	Medium ■□■□	Yes	



## Changing the radio key

If your Visit system is activated for no reason, there is probably a nearby system that triggers yours. In order to avoid radio interference you need to change the radio key on all units. The radio key switches are located under the transmitter cover.

### Here is how you change the radio key:

- 1 Remove the transmitter front cover and move any radio key switch to the up (on position) to change the radio key. By default, all radio key switches are positioned down (off).
- 2 Press and hold the test/function button on the receiver until the green and yellow Visit LEDs blink alternately. Release the button.
- 3 Press the front button on the transmitter within 30 seconds to send the new radio key.
- 4 All Visit LEDs on the receiver blink 5 times to show that the radio key has been changed. It then returns to normal mode.

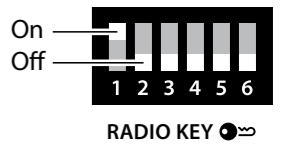

**Note:** All Visit units must be set to the same radio key in order to operate as a group.

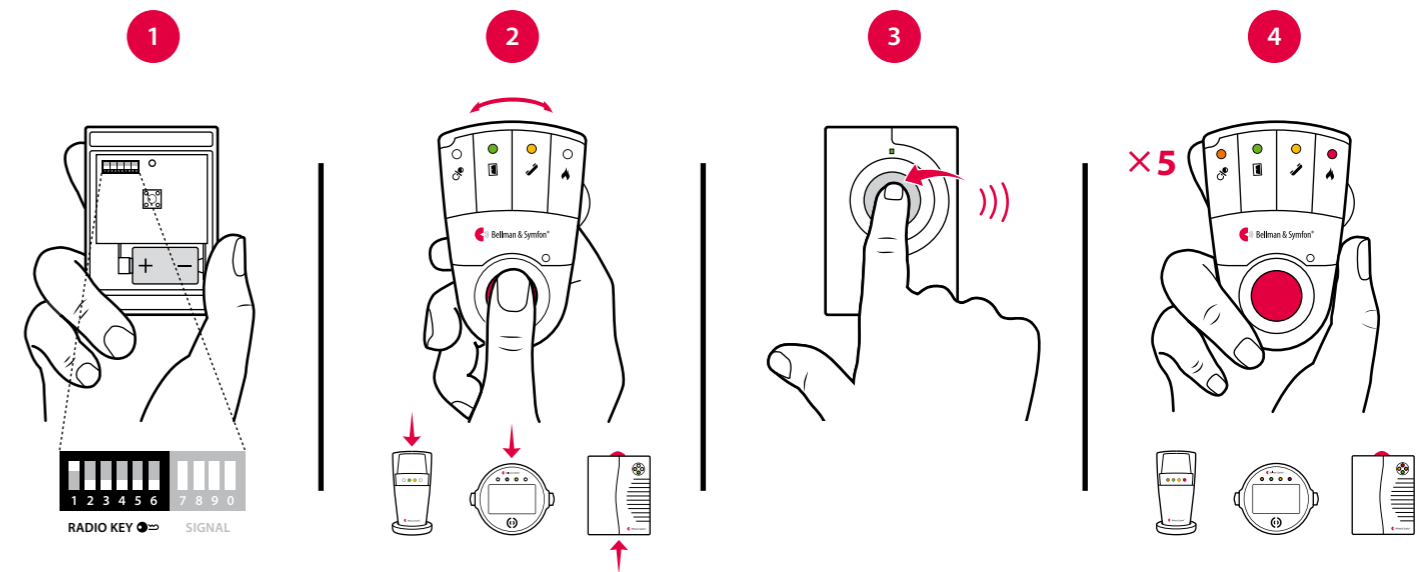

## Troubleshooting

If	Try this
The transmitter LED lights up in yellow when I press the button	<ul style="list-style-type: none"> <li>▪ The battery is nearly depleted. Replace it with an alkaline PX28A or a lithium PX28L type battery.</li> </ul>
The transmitter LED doesn't light up when I press the button	<ul style="list-style-type: none"> <li>▪ Check that the battery is positioned correctly.</li> <li>▪ Replace the battery with an alkaline PX28A or a lithium PX28L type battery.</li> </ul>
The transmitter LED lights up in green but the receiver is not activated	<ul style="list-style-type: none"> <li>▪ Check the receiver batteries and connections.</li> <li>▪ Move the receiver closer to the transmitter to make sure it's within radio range.</li> <li>▪ Check that the units are set to the same radio key, see <b>Changing the radio key</b>.</li> </ul>
The receiver is activated for no apparent reason	<ul style="list-style-type: none"> <li>▪ There is probably another Visit system installed nearby that triggers your system. Change the radio key on all units, see <b>Changing the radio key</b>.</li> </ul>



BE1431

# Visit telephone transmitter

## Buttons and connections

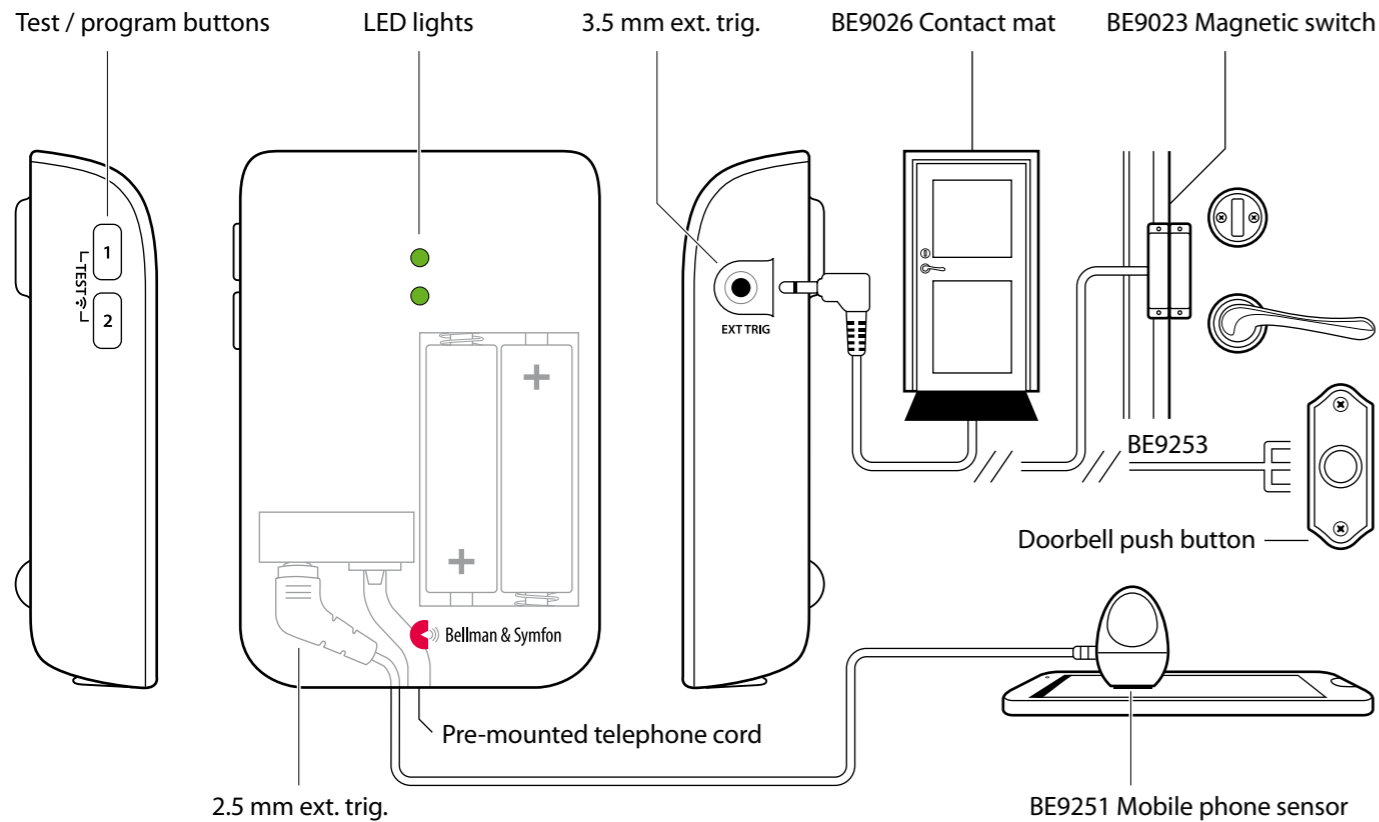

## Technical specifications

### In the box

- BE1431 Visit telephone transmitter
- 2 × 1.5 V AA alkaline batteries
- Telephone cord and adapter
- Screw and wall plug

### Power and battery

- Battery power  
2 × 1.5 V AA lithium or alkaline type batteries
- Power consumption  
Active < 70 mA  
Idle position < 15 µA
- Operation time  
Alkaline batteries ~ 5 years  
Lithium batteries ~ 10 years

### Dimensions and weight

- Height: 100 mm, 4.0"
- Width: 65 mm, 2.6"
- Depth: 27 mm, 1.1"
- Weight: 120 g, 4.2 oz. incl. batteries

### Activation

- The test buttons
- A landline telephone
- A smartphone or tablet via the mobile phone sensor
- A contact mat or magnetic switch
- A doorbell connected to the ext trig

### Environment

- For indoor use only

### Accessories

- BE9251 Mobile phone sensor
- BE9023 Magnetic switch
- BE9026 Contact mat
- BE9253 Ext. trig. cable, 3.5 mm

### Inputs

- RJ11 analogue telephone input
- 2.5 mm external trigger input
- 3.5 mm external trigger input

### Frequency and coverage

- Frequency: 314.91 MHz, 433.92 MHz or 868.30 MHz, depending on region
- Coverage: 50 - 250 m, 55 - 273 yd. depending on the radio frequency and the building's characteristics

## Setting up the transmitter

- 1 Remove the battery pull tab to start the unit. Clean the wall with the wet wipe and remove the protective film from the Velcro.
- 2 Mount the transmitter on the wall. You can also use the supplied screw and plug.
- 3 Connect the telephone adapter as shown below.

**Note:** The appearance of the adapter may differ with territory.

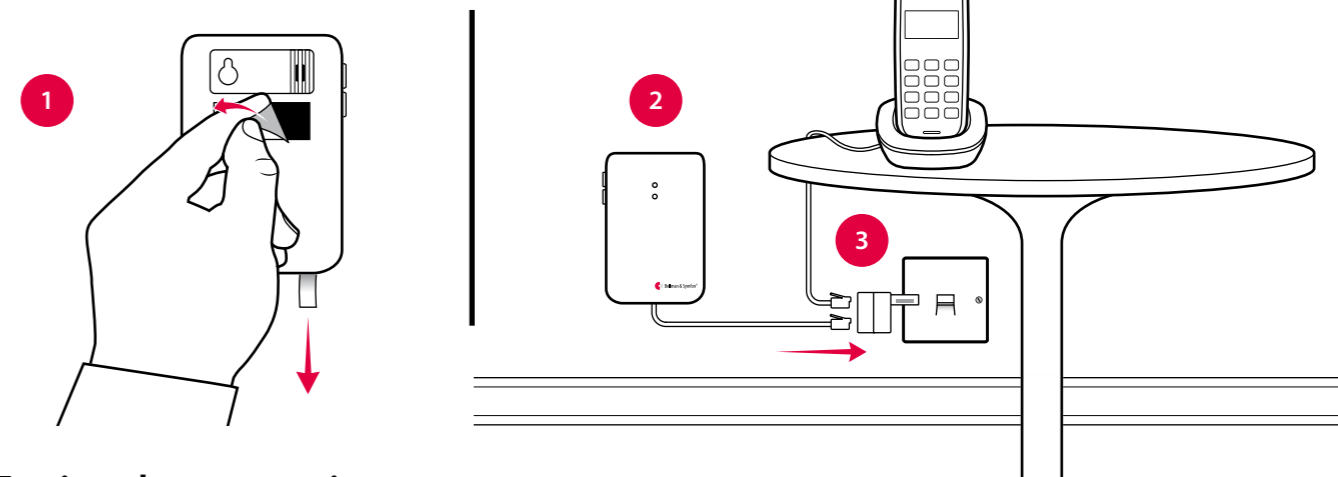

## Testing the connection

### Using the test button

- 1 Press both test buttons simultaneously on the telephone transmitter. The top LED lights up in green to show that a radio signal is being transmitted.
- 2 The yellow Visit LED on the receiver lights up to show that the signal was received. In addition, it starts to sound, flash or vibrate depending on the receiver.

**Note:** If you have changed the signal pattern, it will react in accordance with the table on the following spread.

### Using a mobile phone

- 1 Use for instance a mobile phone to call the landline telephone. The top LED on the transmitter lights up in green to show that an incoming call is detected.
- 2 The yellow Visit LED on the receiver lights up to show that the radio signal was received. In addition, it starts to sound, flash or vibrate depending on the receiver.

**Note:** If you have changed the signal pattern, it will react in accordance with the table on the following spread.

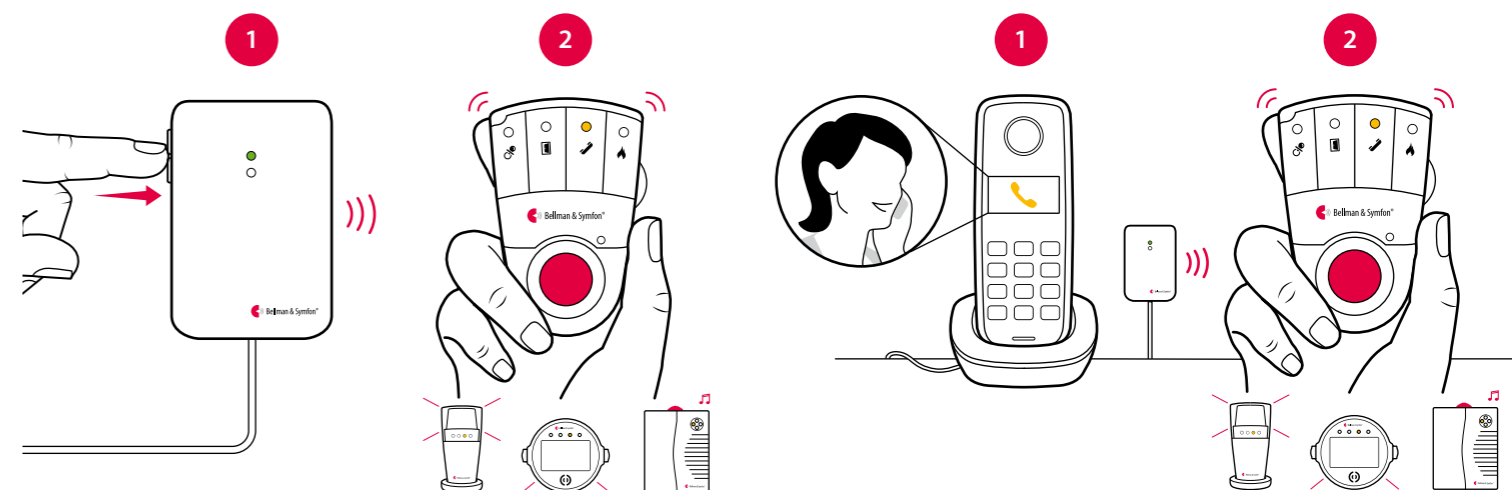



# Visit telephone transmitter

## Default signal pattern

When the telephone transmitter is activated by an incoming call or a triggered accessory, the following happens:

- 1 The LED on the transmitter lights up to show that it's signalling the receiver.
- 2 The Visit LED on the receiver lights up and it starts to sound, flash or vibrate with a certain pace, called signal pattern. The transmitter and the connected accessories determine the signal pattern. The default is as follows:

Transmitter		Receiver signal pattern			
Source	LED	LED	Sound	Vibration	Flash
▪ Landline phone	Green, top	Yellow light	1 × ring signal, low	Medium ■□■□	Yes
▪ Mobile phone sensor	Green, top	Yellow blinks	2 × ring signal, high	Medium ■□■□	Yes
▪ Other accessory	Green, bottom	Green light	1 × door chime, low	Slow ■□□□	Yes

## Changing the signal pattern

The transmitter controls the signal pattern. Open the transmitter front cover and move the signal switches according to the table below to change it:

Transmitter		Receiver signal pattern			
Switch	Source	LED	Sound	Vibration	Flash
	Landline phone / test button Mobile phone sensor Other accessory	Yellow light Yellow blinks Green light	1 × ring signal, low 2 × ring signal, high 1 × door chime, low	Medium ■□■□ Medium ■□■□ Slow ■□□□	Yes Yes Yes
	Landline phone / test button Mobile phone sensor Other accessory	Yellow light Yellow blinks 2 × green blinks	1 × ring signal, low 2 × ring signal, high 2 × door chime, low	Medium ■□■□ Medium ■□■□ Slow ■□□□	Yes Yes Yes
	Landline phone / test button Mobile phone sensor Other accessory	Yellow light Yellow blinks 3 × yellow blinks	1 × ring signal, low 2 × ring signal, high 1 × ring signal, high	Medium ■□■□ Medium ■□■□ Medium ■□■□	Yes Yes Yes
	Landline phone / test button Mobile phone sensor Other accessory	Yellow light Yellow blinks 2 × orange blinks	1 × ring signal, low 2 × ring signal, high Baby melody	Medium ■□■□ Medium ■□■□ Fast ■■■■■■	Yes Yes Yes
	Landline phone / test button Mobile phone sensor Other accessory	2 × yellow blinks Yellow light 3 × orange blinks	2 × ring signal, low 1 × ring signal, low Baby melody	Fast ■■■■■■ Medium ■□■□ Fast ■■■■■■	Yes Yes Yes
	Landline phone / test button Mobile phone sensor Other accessory	2 × yellow blinks Orange blinks Green blinks	2 × ring signal, low Baby melody 2 × door chime, high	Medium ■□■□ Fast ■■■■■■ Slow ■□□□	Yes Yes Yes
	Landline phone / test button Mobile phone sensor Other accessory	Orange blinks 3 × yellow blinks 2 × green blinks	Baby melody 1 × ring signal, high 2 × door chime, low	Medium ■□■□ Medium ■□■□ Slow ■□□□	Yes Yes Yes
	Landline phone / test button Mobile phone sensor Other accessory	3 × yellow blinks 2 × yellow blinks Green blinks	1 × ring signal, high 2 × ring signal, low 2 × door chime, high	Medium ■□■□ Medium ■□■□ Slow ■□□□	Yes Yes Yes



## Changing the radio key

If your Visit system is activated for no reason, there is probably a nearby system that triggers yours. In order to avoid radio interference you need to change the radio key on all units. The radio key switches are located under the transmitter cover.

**Here is how you change the radio key:**

- 1 Open the transmitter front cover and move any radio key switch to the up (on position) to change the radio key. By default, all radio key switches are positioned down (off).
- 2 Press and hold the test/function button on the receiver until the green and yellow Visit LEDs blink alternately. Release the button.
- 3 Press both test buttons simultaneously on the transmitter within 30 seconds to send the new radio key.
- 4 All Visit LEDs on the receiver blink 5 times to show that the radio key has been changed. It then returns to normal mode.

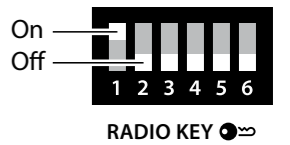

**Note:** All Visit units must be set to the same radio key in order to operate as a group.

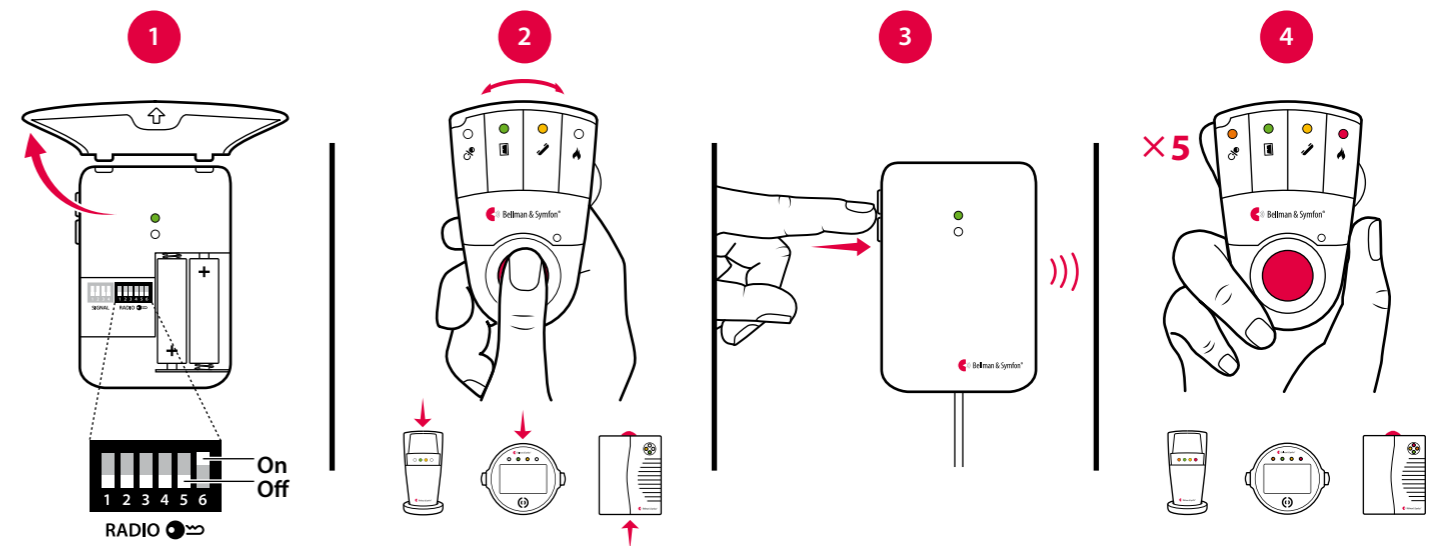

## Troubleshooting

If	Try this
The LEDs blink in orange every minute	▪ Replace the batteries. Only use 1.5 V AA (LR6) lithium or alkaline batteries.
The transmitter LED lights up in green but the receiver doesn't respond	▪ Check the transmitter batteries and the receiver batteries and connections. ▪ Move the receiver closer to the transmitter to make sure it's within radio range. ▪ Check that the units are set to the same radio key, see <b>Changing the radio key</b> .
The transmitter LED doesn't light up when the phone rings or when an accessory is triggered	▪ Press the test buttons on the transmitter. If the LED lights up in green, check all connections. If the LED doesn't light up in green, replace the batteries. Only use 1.5 V AA (LR6) lithium or alkaline batteries.
The transmitter LED doesn't light up when I press the test buttons	▪ Replace the batteries. Only use 1.5 V AA (LR6) lithium or alkaline batteries. If the LED still doesn't light up, contact your retailer for service information.
The receiver is activated for no apparent reason	▪ There is probably another Visit system installed nearby that triggers your system. Change the radio key on all units, see <b>Changing the radio key</b> .



BE1432

# Visit Bluetooth telephone transmitter

## Buttons and connections

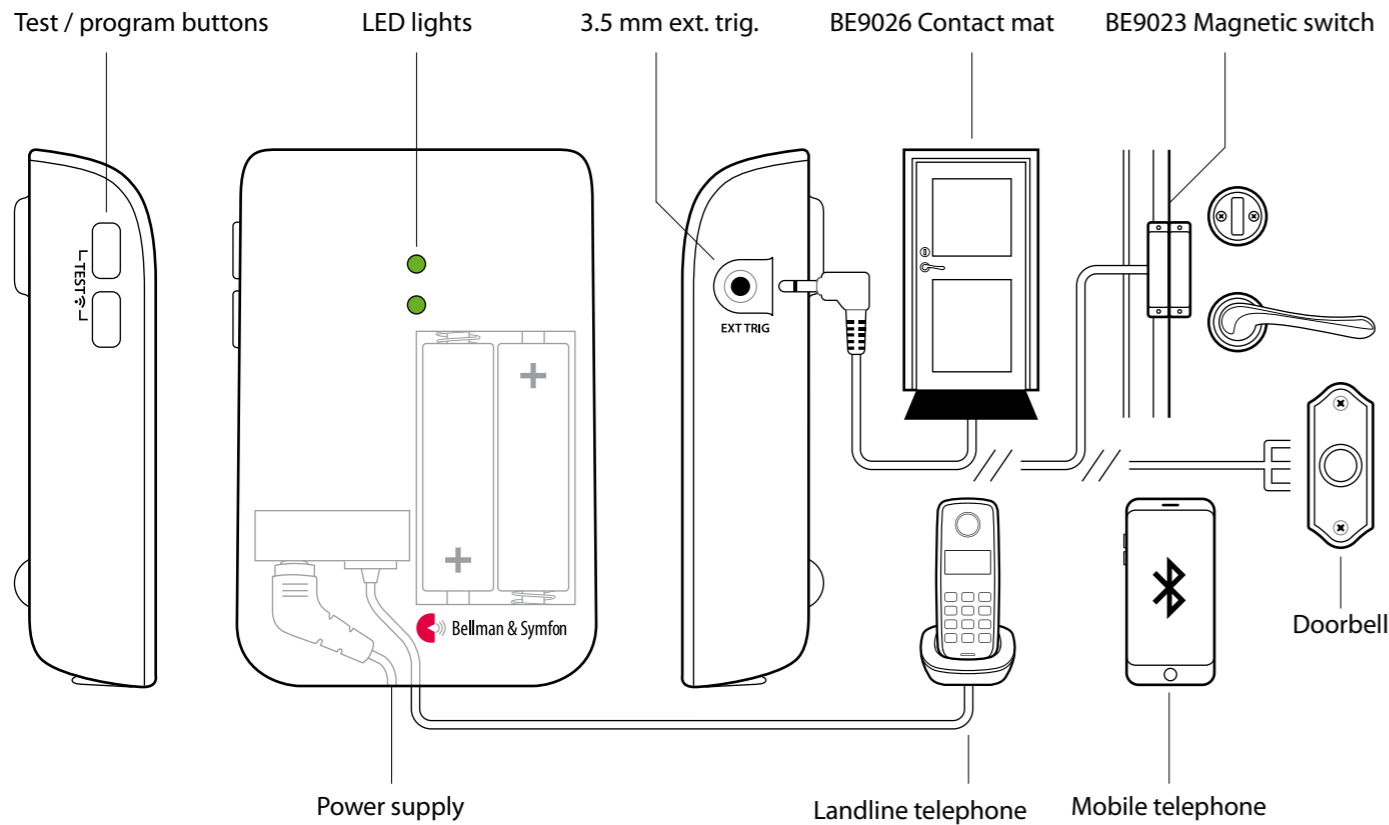

## Technical specifications

### In the box

- BE1432 Visit telephone transmitter
- Power supply and power cable
- 2 × 1.5V AA alkaline batteries
- Pre-mounted telephone cord
- Telephone splitter
- Screw and wall plug

### Compability

- iOS11 and later  
Android 4.4 and later
- iPhone 6S and later  
Modern Android devices

### Power and battery

- Mains power: 5 V DC / 1000 mA
- Batteries: 2 × 1.5 V AA Alkaline

### Dimensions and weight

- Height: 100 mm, 4.0"
- Width: 65 mm, 2.6"
- Depth: 27 mm, 1.1"
- Weight: 120 g, 4.2 oz. incl. batteries

### Activation

- A smartphone via Bluetooth
- A landline telephone
- A contact mat or magnetic switch
- A doorbell connected to the ext. trig
- The test buttons

### Environment

- For indoor use only.
- Temperature: 0 – 35 °C, 32 – 95 °F.
- Humidity: 5% – 95% (non condensing)

### Accessories

- BE9023 Magnetic switch
- BE9026 Contact mat
- BE9253 Ext. trigger cable, 3.5 mm

### Connectivity

- RJ11 analogue telephone input
- 3.5 mm ext. trig input for accessories
- Power supply jack
- Bluetooth 5.0

### Frequency and coverage

- ISM frequency: 868.30 MHz
- ISM coverage: Up to 250 m (275 yd)
- Bluetooth frequency: 2402 – 2480 MHz
- Bluetooth coverage: Up to 50 m

## Installing the app

### 1 Turn on Bluetooth®

Swipe to open the Control Center / Quick Settings Panel and tap the Bluetooth icon.

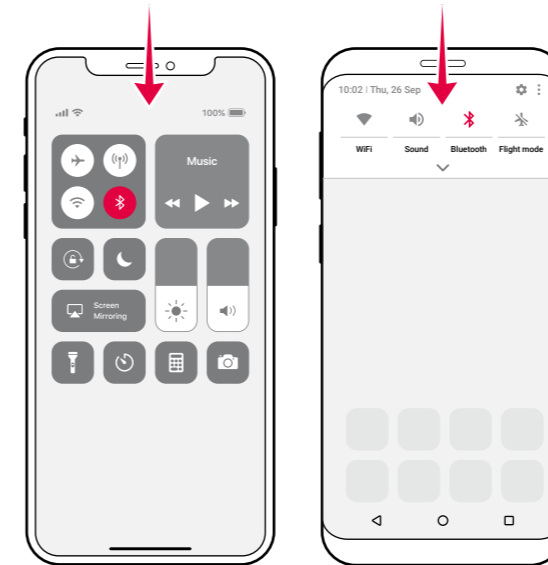

### 2 Install the Visit app

Download the **Bellman Visit** app from the App Store® or Google Play™ and follow the setup instructions.



## Installing the transmitter

### 3 Mount it

Remove the protective film from the Velcro on the back of the transmitter and mount it on the wall. Alternatively use the supplied screw and plug.

### 4 Turn it on

Pull the battery tab to start the transmitter. The indicators light up in green to show that it is on.

### 5 Connect it

Connect the USB cable to the power adapter. Then plug the adapter into a wall outlet. If you have a landline telephone, connect it to the telephone jack using the supplied splitter.

### 6 Test the mobile phone

Have someone call your mobile. The yellow LED on the Visit receiver blinks and it starts to flash, sound or vibrate (depending on the receiver).

### 7 Test the landline phone

Call your landline phone. The yellow LED on the Visit receiver lights up and it starts to flash, sound or vibrate (depending on the receiver).

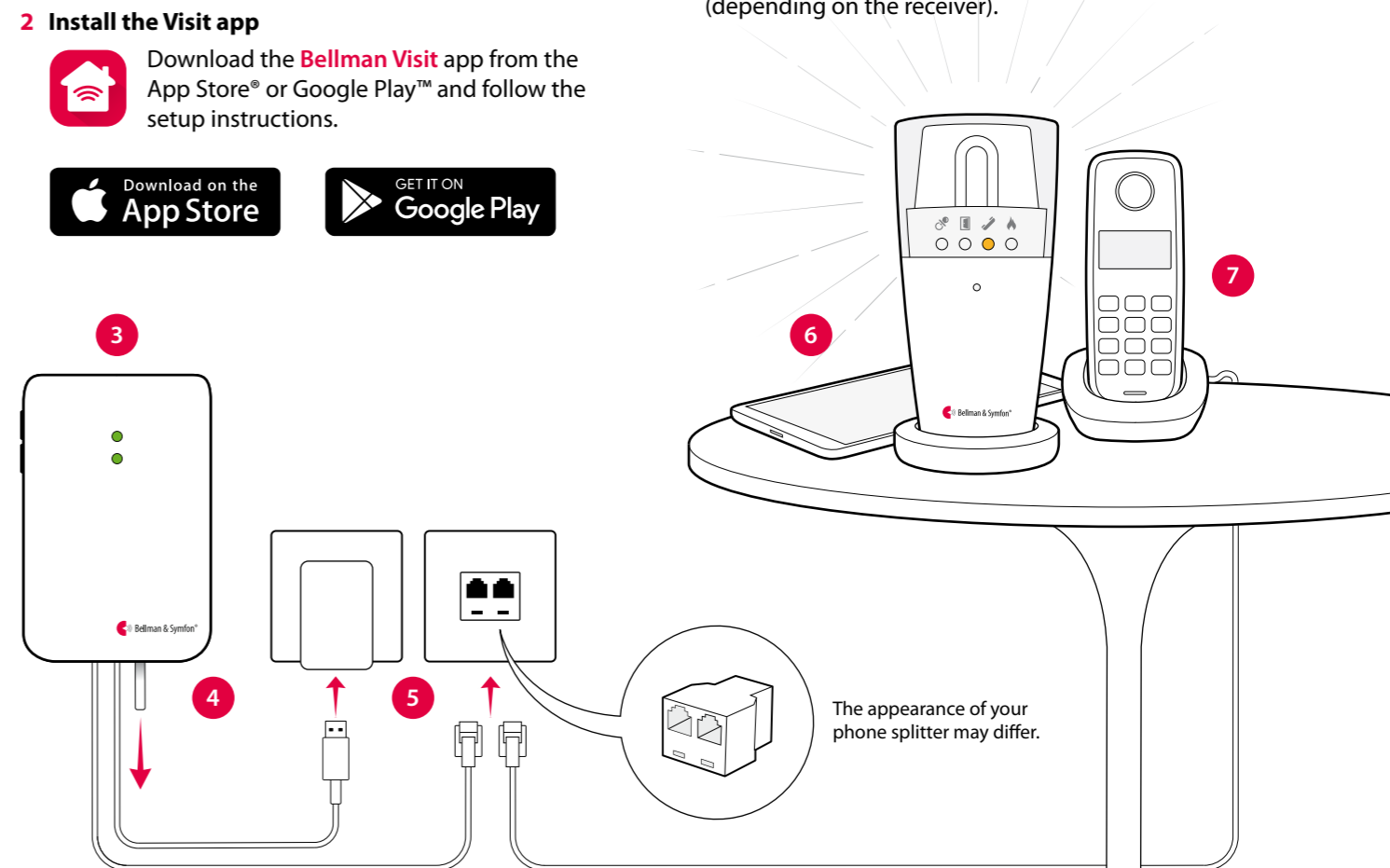



# Visit Bluetooth telephone transmitter

## Using the app

There are times during the day when you probably don't want to be disturbed. The app features four preset **Activities** that gives you full control of your Visit alerts. Just tap an activity to select it.

**Good morning**  
 Visit alerts for both calls and messages during this activity. Select it during daytime, when you don't want to miss out on anything.

**Good night**  
 All Visit alerts are off during this activity. Select it when you go to bed, so you are not woken up by alerts during your sleep.

**Movie night**  
 Visit only alerts for calls during this activity. Select it when you are watching TV, so you're not distracted by a constant flow of messages.

**Dinner time**  
 Visit only alerts for messages during this activity. Select it at dinner, so you don't have to answer incoming calls in the middle of the main course.

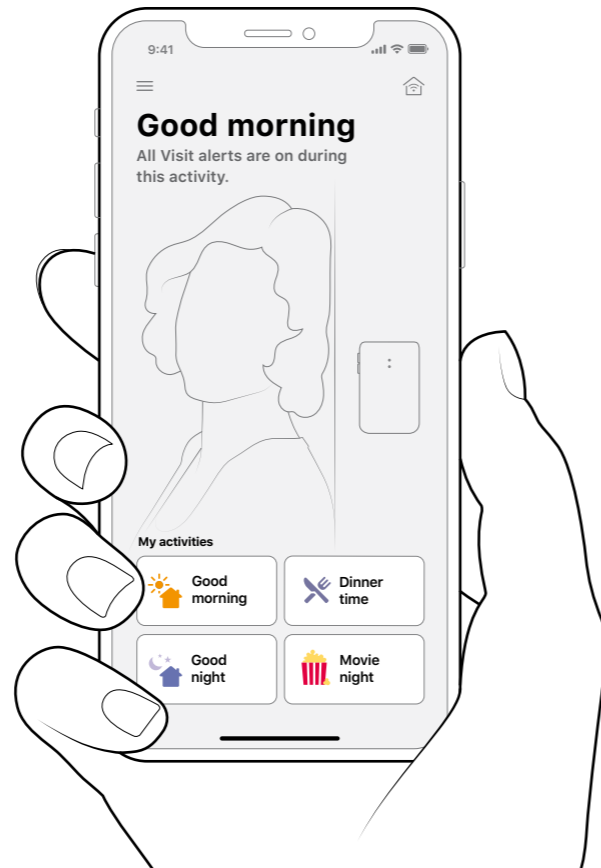

## Default signal pattern

When the telephone transmitter is activated by an incoming call or a triggered accessory, the following happens:

- 1 The LED on the transmitter lights up to show that it's signalling the receiver.
- 2 The Visit LED on the receiver lights up and it starts to sound, flash or vibrate with a certain pace, called signal pattern. The transmitter and the connected accessories determine the signal pattern. The default is as follows:

Transmitter		Receiver signal pattern			
Source	LED	LED	Sound	Vibration	Flash
▪ Landline phone	Green, top	Yellow light	1 × ring signal, low	Medium ■□■□	Yes
▪ Mobile phone	Green, top	Yellow blinks	2 × ring signal, high	Medium ■□■□	Yes
▪ Accessory	Green, bottom	Green light	1 × door chime, low	Slow ■□□□	Yes

## Changing the signal pattern

The transmitter controls the signal pattern. Open the transmitter front cover and move the signal switches, see **Changing the signal pattern** on BE1431.

## Changing the radio key

If your Visit system is activated for no reason, there is probably a nearby system that triggers yours. In order to avoid radio interference, you need to change the radio key on all units, see **Changing the radio key** on BE1431.

## Troubleshooting

If	Try this
The transmitter LEDs blink in red every minute	This means that the power adapter is disconnected, and the backup battery level is low. <ul style="list-style-type: none"> <li>▪ Make sure that the power adapter is connected to mains.</li> <li>▪ Remove the cover and replace the batteries. Only use 1.5 V AA (LR6) alkaline batteries.</li> </ul>
The Visit receiver doesn't respond when the landline phone rings or when an accessory is triggered	Start by pressing both test buttons on the transmitter to send a signal to your Visit receiver. <p><b>If the transmitter LED lights up in green, try the following:</b></p> <ul style="list-style-type: none"> <li>▪ Move the Visit receiver closer to the transmitter to make sure it's within Visit radio range.</li> <li>▪ Make sure that the batteries on your Visit receiver are not depleted and / or that it is connected to mains power.</li> <li>▪ Make sure all cables between the transmitter and the accessories are properly connected.</li> <li>▪ Make sure the units are set to the same radio key, see <b>Changing radio key</b> on BE1431.</li> </ul> <p><b>If the transmitter LED doesn't light up in green, try the following:</b></p> <ul style="list-style-type: none"> <li>▪ Make sure that the power adapter is connected and that the backup batteries are not depleted. If the LED still doesn't light up in green, contact your retailer for information on warranty and service.</li> </ul>
The Visit receiver doesn't respond when the mobile phone rings or receives a message.	Start by checking that the activity you have chosen on the app home screen alerts for incoming calls and messages on your device, see <b>Using the app</b> . Continue by pressing both test buttons on the transmitter. <p><b>If the transmitter LED lights up in green, try the following:</b></p> Start by checking the Bluetooth connection on the app home screen. If the top right house icon is red and crossed out, try the following: <ul style="list-style-type: none"> <li>▪ Move the mobile phone closer to the transmitter to make sure it's within Bluetooth range (approx. 10 meters).</li> <li>▪ Swipe to open the Control Centr / Quick Settings Panel and tap the Bluetooth icon to turn Bluetooth off and on.</li> <li>▪ Force-quit the app and open it again. <b>Note:</b> It's not enough to just close it.</li> <li>▪ Check compatibility with third-party apps like Messenger, Skype, WhatsApp, WeChat or Line. Depending on model, your mobile phone may fail to forward notifications for calls and messages to your Visit system. Test the app by asking someone to call or send a message via the app. If your Visit receiver isn't activated (even though the selected activity is pre-set to forward the notification), the third-party app may be incompatible.</li> </ul> <p><b>If the Visit receiver still doesn't respond, try the following:</b></p> <ul style="list-style-type: none"> <li>▪ Move the Visit receiver closer to the transmitter to make sure it's within Visit radio range.</li> <li>▪ Make sure that the batteries on your Visit receiver are not depleted and/or that it is connected to mains power.</li> <li>▪ Make sure the units are set to the same radio key, see <b>Changing radio key</b> on BE1431.</li> </ul> <p><b>If the transmitter LED doesn't light up in green, try the following:</b></p> <ul style="list-style-type: none"> <li>▪ Make sure that the power adapter is connected. If the LED still doesn't light up in green, contact your retailer for information on warranty and service.</li> </ul>
The Visit receiver is activated for no apparent reason	<ul style="list-style-type: none"> <li>▪ Start by checking if the Activity you have chosen on the app home screen produces Visit alerts for events in your mobile phone that you don't want, see <b>Using the app</b>.</li> <li>▪ If that's not the case, a nearby Visit system might trigger your system. Change the radio key on all Visit units, see <b>Changing radio key</b> on BE1431.</li> </ul>



# Visit baby monitor

## Buttons and connections

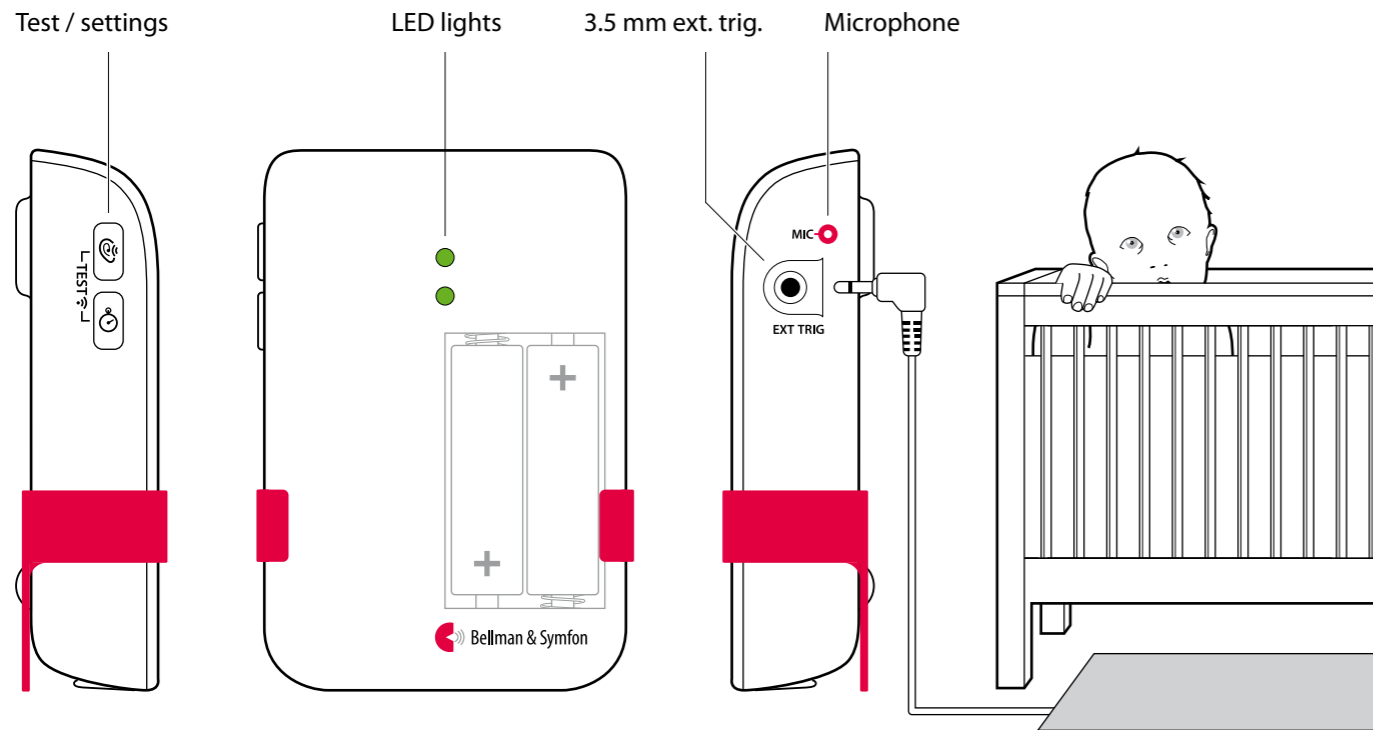

**!** Always make sure the baby monitor is out of the child's reach. Never place the baby monitor in the child's crib or playpen.

BE9026 contact mat

## Technical specifications

### In the box

- BE1491 Visit baby monitor
- 2 × 1.5 V AA alkaline batteries
- Pre-mounted table stand
- Screw and wall plug

### Power and battery

- Battery power  
2 × 1.5 V AA lithium or alkaline type batteries
- Power consumption  
Active < 70 mA  
Idle position < 400 µA
- Operation time  
Alkaline batteries ~ 6 months  
Lithium batteries ~ 1 year

### Dimensions and weight

- Height: 100 mm, 4.0"
- Width: 65 mm, 2.6"
- Depth: 27 mm, 1.1"
- Weight: 120 g, 4.2 oz. incl. batteries

### Activation

- The internal mic. and test buttons
- The contact mat accessory

### Settings

- Sensitivity  
65 dB, 75 dB, 85 dB
- Delay  
30 sec, 10 sec, 1 sec

### Environment

- For indoor use only  
Operating temperature  
15° to 35° C, 59° to 95° F
- Relative humidity  
5% to 95%, non-condensing

### Frequency and coverage

- Frequency: 314.91 MHz, 433.92 MHz or 868.30 MHz, depending on region
- Coverage: 50 - 250 m, 55 - 273 yd. depending on the radio frequency and the building's characteristics

### Accessories

- BE9026 Contact mat  
Alerts you if your child leaves the bed

## Setting up the baby monitor

- 1 Remove the battery pull tab to start the unit.  
(You can press and hold both test buttons for 3 seconds to turn it on/off.)
- 2 Place the baby monitor on the bedside table or mount it on the wall using the supplied screw and plug.  
The recommended distance is 0.5 – 2 m, always out of reach from the child.

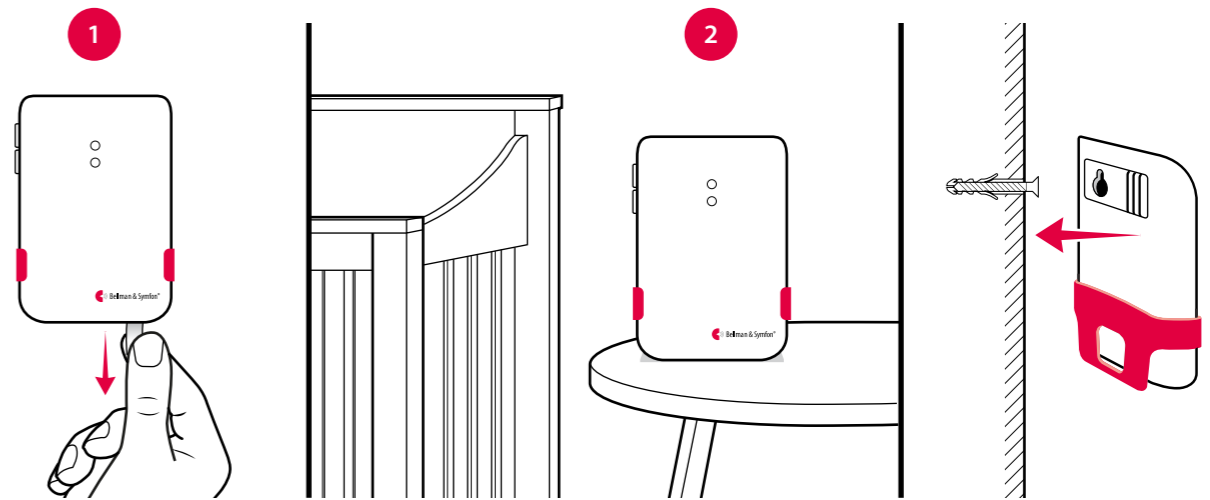

## Testing the connection

### Using the test button

- 1 Press both test buttons simultaneously on the baby monitor. The top LED lights up in green to show that a radio signal is being transmitted.
- 2 The orange Visit LED on the receiver lights up to show that the signal was received. In addition, it starts to sound, flash or vibrate depending on the receiver.

**Note:** If you have changed the signal pattern, it will react in accordance with the table on the following spread.

### Using your voice

- 1 Stand by the baby monitor and make some noise. The top LED lights up in green to show that the sound was detected.
- 2 The orange Visit LED on the receiver lights up to show that the radio signal was received. In addition, it starts to sound, flash or vibrate depending on the receiver.

**Note:** If you have changed the signal pattern, it will react in accordance with the table on the following spread.

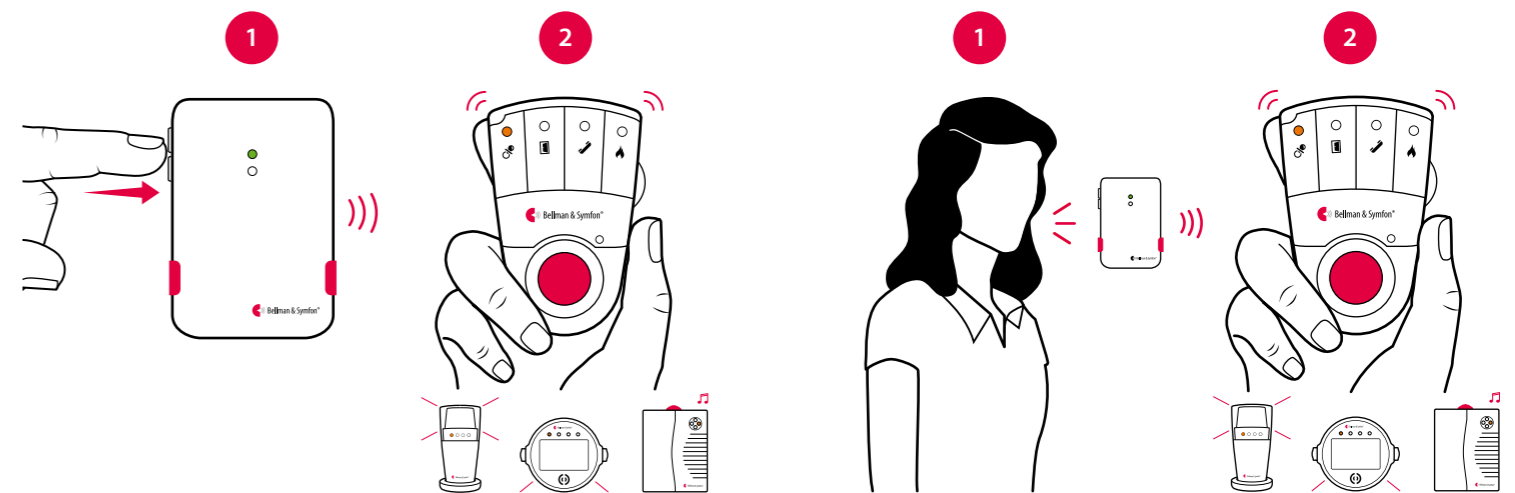



# Visit baby monitor

## Adjusting the settings

The buttons for sensitivity and delay are located on the left side of the baby monitor. When you press the button, the corresponding LED colour shows the current setting. Then press repeatedly to adjust the setting.

- If the baby monitor is not activated when the baby cries – increase the sensitivity.
- If the baby monitor is activated too easily – reduce the sensitivity.
- If the baby monitor is activated too early or too late – adjust the delay.

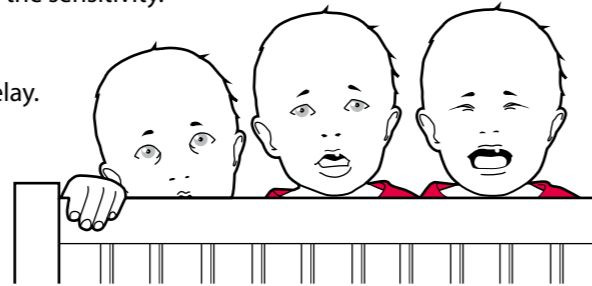

### Sensitivity settings

	65 dB	Red
	75 dB	Orange
	85 dB	Green

### Delay settings

	30 s	Red
	10 s	Orange
	1 s	Green

## Default signal pattern

When the baby monitor is activated by the baby's voice or the contact mat, the following happens:

- 1 The LED on the baby monitor lights up in green to show that it is signalling the receiver.
- 2 The Visit LED on the receiver lights up in orange and it starts to sound, flash or vibrate with a certain pace, called signal pattern. The baby monitor and the contact mat accessory determine the signal pattern. The default is as follows:

Baby monitor		Receiver signal pattern			
Source	LED	LED	Sound	Vibration	Flash
▪ Baby voice	Green, top	Orange light	Baby melody	Fast ■■■■■■	Yes
▪ Contact mat	Green, bottom	Green light	1×door chime, low	Slow ■■■■	Yes

## Changing the signal pattern

If you have more than one child, you can set a unique Visit LED pattern for each baby monitor. Just open the front cover and move any signal switch to the up (on position) and make sure the other switches are down (off).



Baby monitor		Receiver signal pattern			
Switch	Source	LED	Sound	Vibration	Flash
	Baby monitor 1	Orange light	Baby melody	Fast ■■■■■■	Yes
	Contact mat 1	Green light	Baby melody	Fast ■■■■■■	Yes
	Baby monitor 2	2×orange blinks	Baby melody	Fast ■■■■■■	Yes
	Contact mat 2	2×green blinks	Baby melody	Fast ■■■■■■	Yes
	Baby monitor 3	3×orange blinks	Baby melody	Fast ■■■■■■	Yes
	Contact mat 3	3×orange blinks	Baby melody	Fast ■■■■■■	Yes
	Baby monitor 4	Orange blinks	Baby melody	Fast ■■■■■■	Yes
	Contact mat 4	Orange blinks	Baby melody	Fast ■■■■■■	Yes

## Changing the radio key

If your Visit system is activated for no reason, there is probably a nearby system that triggers yours. In order to avoid radio interference, you need to change the radio key on all units. The radio key switches are located under the monitor cover.

### Here is how you change the radio key:

- 1 Carefully remove the table stand and open the front cover on the baby monitor. Move any radio key switch to the up (on position) to change the radio key.
- 2 Press and hold the test/function button on the receiver until the green and yellow Visit LEDs blink alternately. Release the button.
- 3 Press both test buttons simultaneously on the baby monitor within 30 s to send the new radio key.
- 4 All Visit LEDs on the receiver blink 5 times to show that the radio key has been changed. It then returns to normal mode.



**Note:** All Visit units must be set to the same radio key in order to operate as a group.

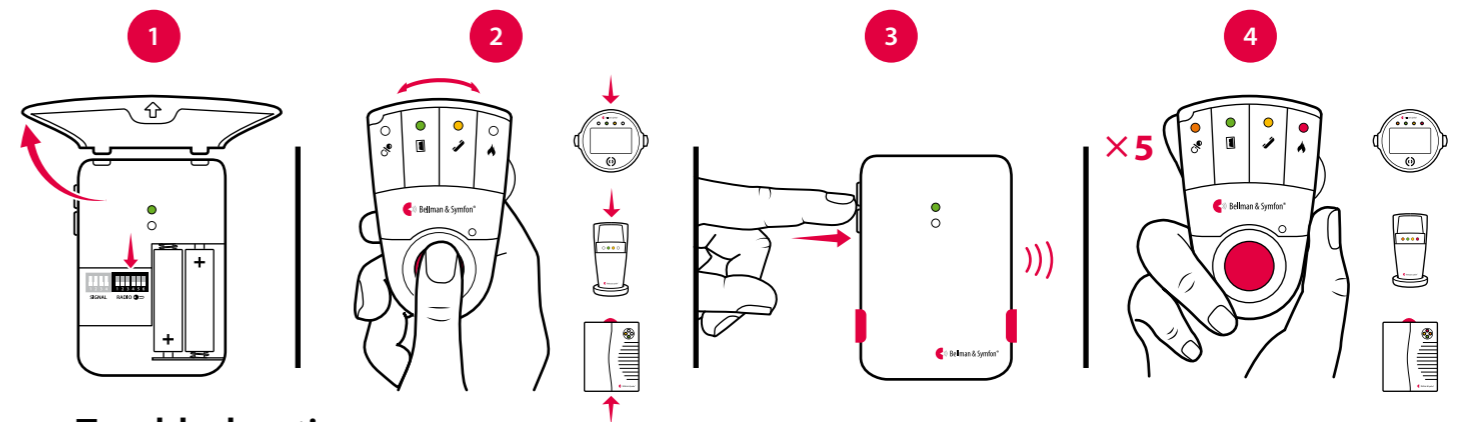

## Troubleshooting

If	Try this
The LEDs blink in orange every minute	▪ Replace the batteries. Only use 1.5 V AA (LR6) lithium or alkaline batteries.
The baby monitor LED lights up in green but the receiver is not activated	▪ Check the baby monitor batteries and the receiver batteries and connections. ▪ Move the receiver closer to the baby monitor to make sure it's within range. ▪ Check that the units are set to the same radio key, see <b>Changing the radio key</b> .
The baby monitor LED doesn't light up even though the baby is crying	▪ Move the baby monitor closer to the baby or increase the microphone sensitivity, see <b>Adjusting the settings</b> . ▪ <b>Note:</b> Always make sure the baby monitor is out of the child's reach. Never place the baby monitor in the child's crib or playpen.
The baby monitor is activated too easily	▪ Reduce the sensitivity or move the baby monitor further away from the crib, see <b>Adjusting the settings</b> .
The baby monitor is activated too early	▪ Increase the delay. For more information, see <b>Adjusting the settings</b> .
The baby monitor is activated too late	▪ Reduce the delay, see <b>Adjusting the settings</b> .
The receiver is activated for no apparent reason	▪ There is probably another Visit system installed nearby that triggers your system. Change the radio key on all units, see <b>Changing the radio key</b> .



BE1481

# Visit smoke alarm – optothermal

## Buttons and controls

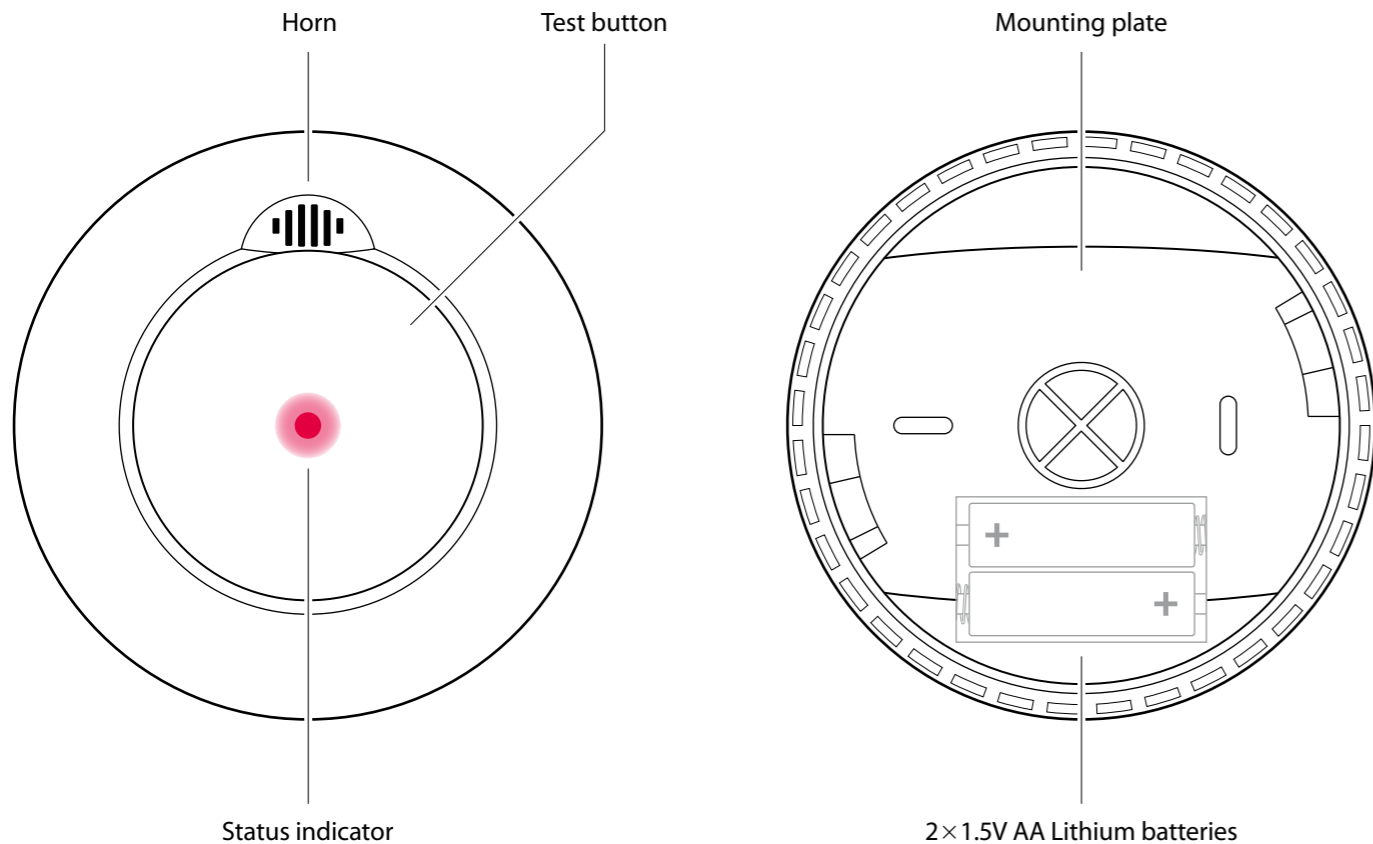

## Technical specifications

### In the box

- BE1481 Visit smoke alarm
- 2 x 1.5V AA Lithium batteries
- 2 x Screws and plugs
- Mounting plate
- User manual

### Power and battery

- Battery type  
2 x 1.5V AA Energizer Lithium L91
- Power consumption  
Active < 75 mA  
Idle < 15 µA
- Operation time  
Minimum 5 years

### Size and weight

- Diameter: 120 mm
- Depth: 37 mm
- Weight: 165 g, incl. batteries

### Sensor type

- Optical smoke and thermal detection  
Min 85 dB(A) @ 3m, Frequency: 3.2 kHz

### Activation

- Via the test button
- Via the smoke detector  
Smoke sensitivity: 0.115 – 0.168 dB/m
- Via the thermal sensor  
Heat sensitivity: 54°–70 °C, 129°–158° F

### Frequency and coverage

- Radio frequency  
868.30 MHz
- Coverage: Up to 200 m (218 yd.), clear line of sight. It depends on the building's characteristics and radio conditions.

### Environment

- For indoor use only
- Operating temperature  
4° – 40° C, 39° – 104° F
- Relative humidity  
15% – 95% R.H. (non-condensing)

### Regulatory

- Meets EN14604:2005 and AC:2008

## Installing the smoke alarm

- 1 Remove the mounting bracket from the smoke alarm by turning it counter-clockwise and insert the supplied batteries to start the unit.
- 2 Fix the mounting bracket to the ceiling using the supplied screws and plugs. Make sure it's located at least 50 cm, (20") from walls and other obstructions, see **Location and positioning**. For alternative mounting options see p 34.
- 3 Fit the smoke alarm to the bracket by turning it clockwise until it snaps into place.

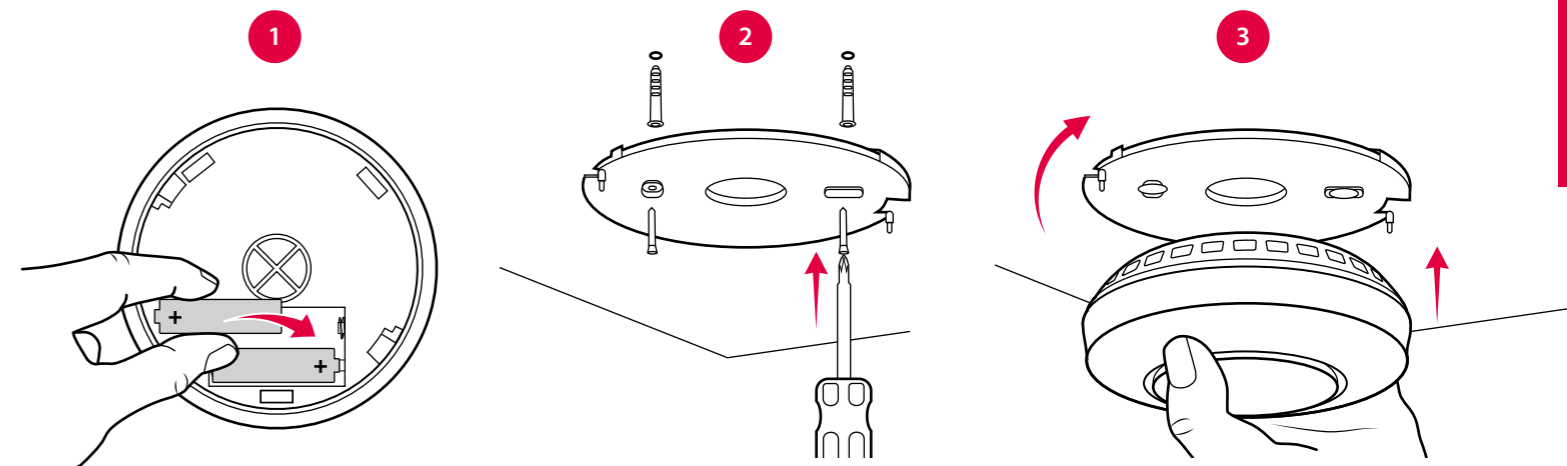

## Location and positioning

Fit the smoke alarms in the center of the ceiling outside the bedrooms, at least 50 cm, (20") from any wall. If the bedrooms are in different areas of the house, separate smoke alarms are recommended. In multi-storey properties, install at least one smoke alarm on each floor.

Avoid kitchens, fireplaces or garages, as cooking fumes and car exhaust may cause false alarms. The smoke alarm should not be installed in damp spaces, close to fans, etc. or in agricultural buildings.

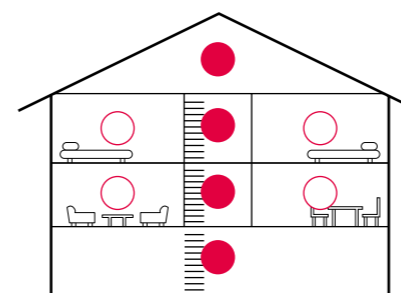

- = Minimum
- = Additional smoke alarm

## Testing the connection

- 1 Press and hold the smoke alarm test button until the alarm sounds and the status indicator starts to blink. The smoke alarm transmits a radio signal to the receiver.
- 2 The red Visit LED on the receiver lights up to show that the signal was received. In addition, it starts to sound, flash or vibrate depending on the receiver.

**Note:** The smoke alarm will stop sounding shortly after the button is released and the receiver will time out within 1 min.

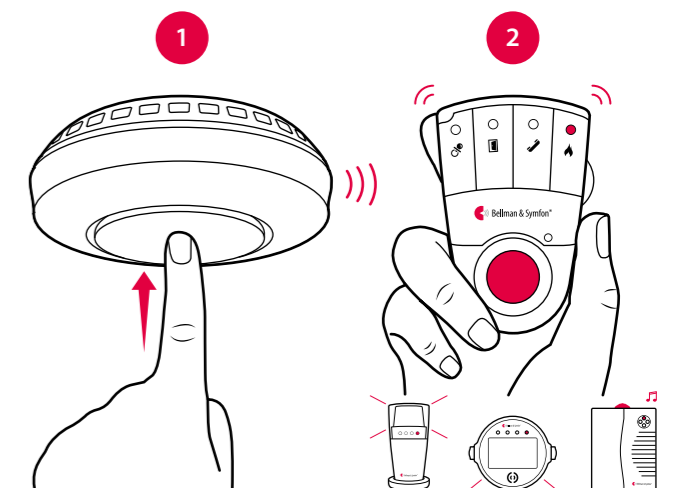





BE1481

# Visit smoke alarm – optothermal

## Signal pattern

The smoke alarm status indicator blinks in red once every 50 s to show that it is working correctly. Depending on the cause of the alarm, the signal patterns are as follows:

Smoke alarm			Receiver signal pattern			
Cause	Status LED	Sound	Visit LED	Sound	Vibration	Flash
Smoke	Blinking in red	■■■□	Blinking in red	Fire alarm	Long	Yes
Heat	Blinking in red	■■■■■	Blinking in red	Fire alarm	Long	Yes
Low battery	1 blink / 50 s	1 chirp / 50 s	Blinking in red	–	–	–
Faulty unit	1 blink / 50 s	1 chirp / 50 s	–	–	–	–

## Using broadcast

If you want the smoke alarm signal to be transmitted to *all* Visit receivers within radio range, you can activate broadcast mode. This will override the radio key settings.

### To activate broadcast

- Press the test button three times in quick succession. The smoke alarm chirps and blinks three times to confirm that broadcast is activated. Please note that low battery warnings will only be transmitted to receivers with the same radio key.

**Note:** In broadcast mode, the alarm cannot be activated with the test button. Use smoke detector aerosol spray.

### To deactivate broadcast

- Press the smoke alarm test button three times in quick succession. The smoke alarm emits a steady sound and light for 2 seconds to confirm that broadcast is deactivated. The smoke alarm has now returned to the latest stored radio key.

## Silence function

### Using the silence function

- In case of a nuisance alarm, press and hold the test button for 2 s to silence it temporarily. The status indicator blinks in red every 16 s to confirm. For security reasons, the silence mode stops automatically after 10 minutes.

## Test and maintenance

Test the smoke alarm and radio connection regularly, preferably each week, e.g. during cleaning, but at least once per month. Always test it immediately after any holidays or other extended periods of absence. Clean it with a damp cloth. After changing battery, vacuum clean with a soft brush. Do not paint over the smoke alarm.

If	Try this
Nothing happens when I press the smoke alarm test button	<ul style="list-style-type: none"> <li>Check that the batteries are inserted correctly.</li> <li>Replace the smoke alarm batteries. Only use AA Energizer lithium L91 batteries.</li> <li>Check the age of the unit, see the “Replace by” label on the unit.</li> </ul>
The smoke alarm beeps when I press the test button, but the Visit receiver is not responding	<ul style="list-style-type: none"> <li>Check the smoke alarm batteries and the Visit receiver batteries and connections.</li> <li>Move the Visit receiver closer to the smoke alarm to make sure it's within radio range.</li> <li>Check that the units are set to the same radio key, see <b>Changing the radio key</b>.</li> </ul>
The Visit receiver is activated for no apparent reason	<ul style="list-style-type: none"> <li>Check if smoke or steam from the kitchen or bathroom causes the false alarm.</li> <li>Check if the Visit LED signals for low battery. If so, change the smoke alarm batteries.</li> <li>If the problem persists, there is probably another Visit system nearby that triggers yours. Change the radio key on all units, see <b>Changing the radio key</b>.</li> <li>Check if there is another system nearby on broadcast mode.</li> </ul>
The smoke alarm beeps for no reason	<ul style="list-style-type: none"> <li>Remove contamination from cobwebs or dust. If the problem persists, replace the unit.</li> </ul>

## Changing the radio key

If your Visit system is activated for no reason, there is probably a nearby system that triggers yours. In order to avoid radio interference, you need to change the radio key on all units. The procedure differs depending on your system setup.

### Systems with *different* types of transmitters

Start by changing the radio key on all *other* transmitters in the system by moving any of the radio key switches, see the corresponding user manual. **Note:** All transmitters must be set to the same radio key to operate as a group.

#### Step 1: Change the radio key on the BE1481 Smoke alarm

- Remove one of the batteries to turn off the smoke alarm and wait at least 30 s. Press and hold the test button as you insert the battery again. Continue pressing the test button until the status indicator starts to flash. Now, release the button. The status indicator will flash rapidly to show that the smoke alarm is ready to receive the new radio key.
- Press the test button on any *other* transmitter within 25 s to transmit the new radio key.
- The smoke alarm status indicator emits a steady light to show that the radio key has been received. Press the test button on the smoke alarm to save the new radio key and exit the programming mode.

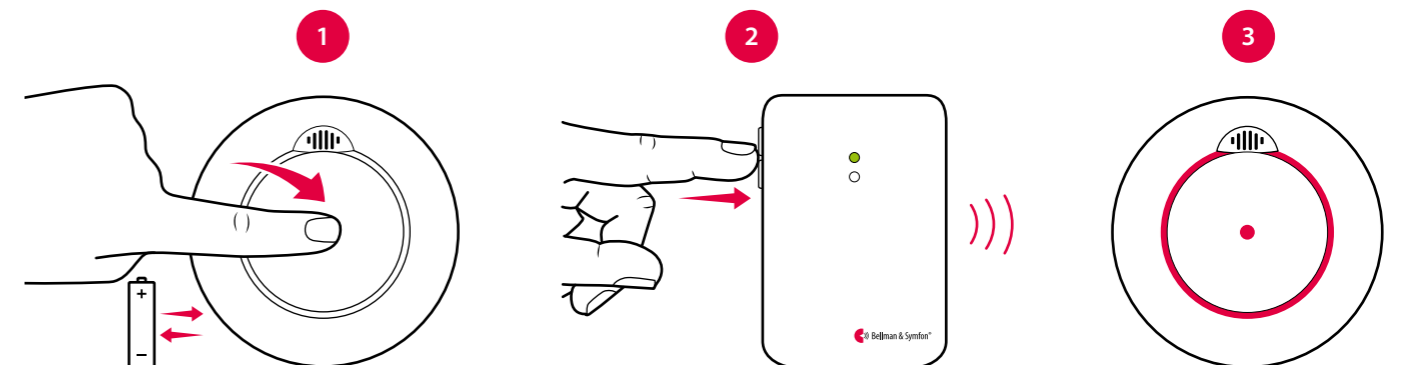

#### Step 2: Change the radio key on the Visit receiver

- Press and hold the test button on the receiver until the green and yellow Visit LEDs blink alternately. Release the button.
- Press the test button on any transmitter within 25 s to transmit the new radio key.
- All Visit LEDs on the receiver blink 5 times to show that the radio key has been changed.



# Visit smoke alarm – optothermal

## Changing the radio key

### Systems with *only* BE1481 Smoke alarm

#### Step 1: Change the radio key on the BE1481 Smoke alarm

- 1 Remove one of the batteries to turn off the smoke alarm and wait at least 30 s. Press and hold the test button as you insert the battery again and continue holding it until the status LED goes from slow to rapid flashes. Release the button to enter the programming mode.
- 2 The smoke alarm is reset to the default radio key 0 and the status LED lights up to confirm.
- 3 **Within 4 s**, press and hold the test button until the LED goes out to select the next radio key. Radio key 1 is now selected and the status LED lights up to confirm. Follow this procedure to advance to the next radio key. There are 9 radio keys available. If you continue beyond radio key 9, the unit will reset to radio key 0.
- 4 After 4 s, the smoke alarm automatically exits the programming mode and the LED goes out to confirm.

**Note:** Follow the steps above to change the radio key on all BE1481 smoke alarms in your Visit system.

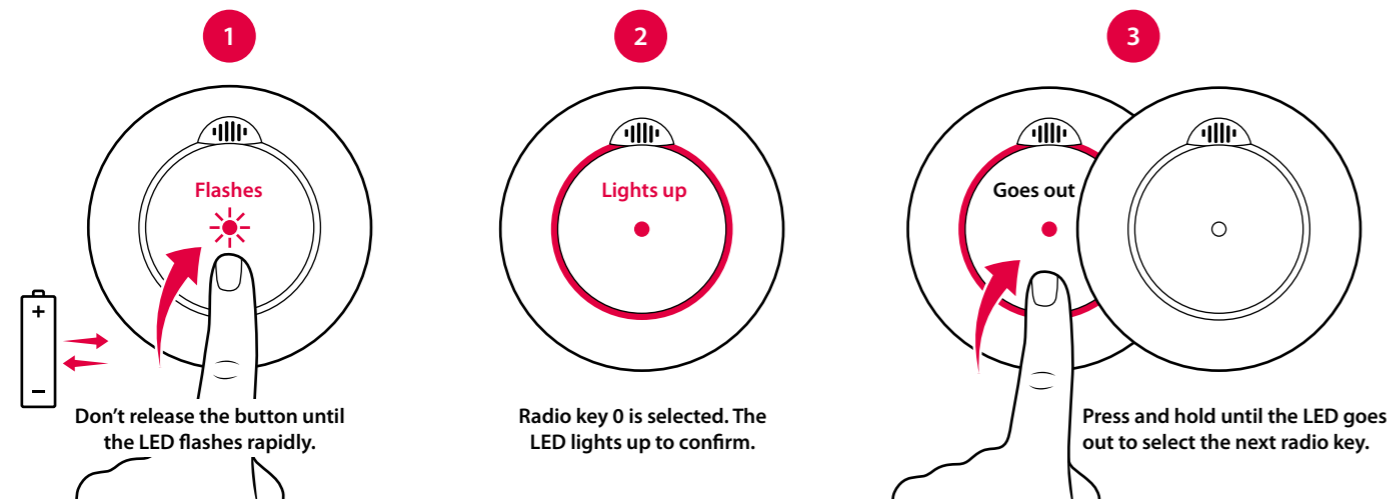

#### Step 2: Change the radio key on the Visit receiver

- 1 Press and hold the test button on the receiver until the green and yellow Visit LEDs blink alternately. Release the button.
- 2 Press the test button on any transmitter within 25 s to transmit the new radio key.
- 3 All Visit LEDs on the receiver blink 5 times to show that the radio key has been changed.



# Visit accessory



BE9175

## Magnetic mount kit

### For easy installation of smoke alarms

The magnetic mount kit offers a quick and easy alternative to traditional screws and plugs. It consists of a self-adhesive plate that you fix to the ceiling and a self-adhesive magnetic plate that you attach to your smoke alarm.

### Installation procedure

- 1 Remove the protective film from the non-magnetic plate.
- 2 Mount the plate on the ceiling and hold for 10 s.
- 3 Remove the protective film from the magnetic plate and attach it to the smoke alarm. Hold for 10 s.
- 4 Place the smoke alarm on the ceiling plate.

**Note:** The mounting kit is not suitable for vinyl wallpapers, anti-adhesive coatings, silicone-coated or Teflon-coated surfaces. The diameter of the smoke alarm cannot be less than 70 mm.

### Technical specifications

- Diameter 70 mm
- Weight 25 g
- Color White
- Environment For indoor use only

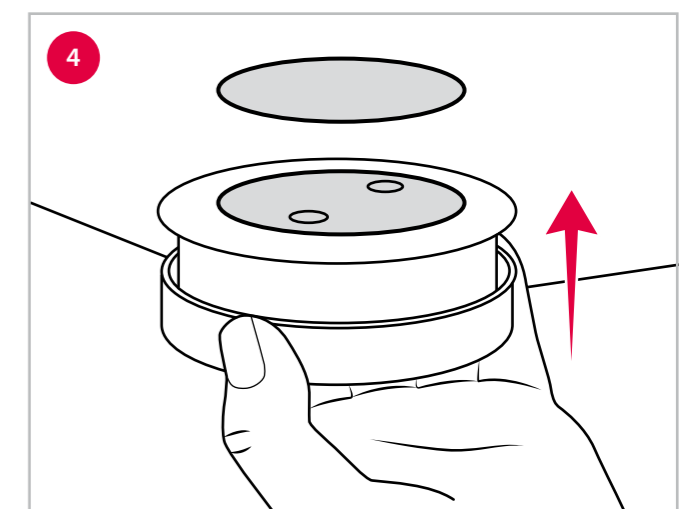
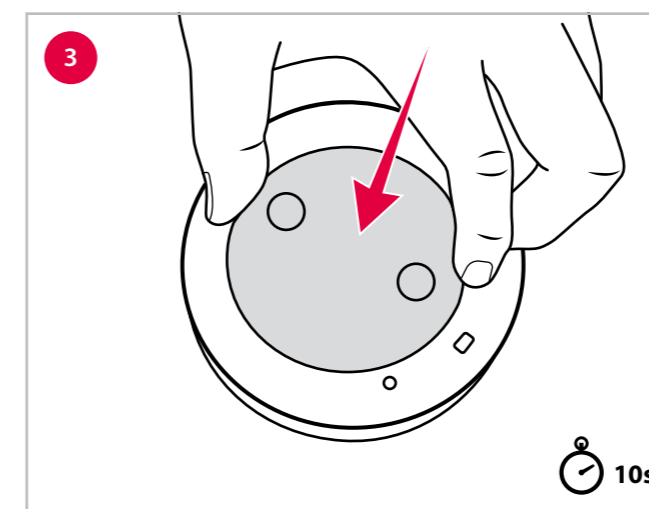
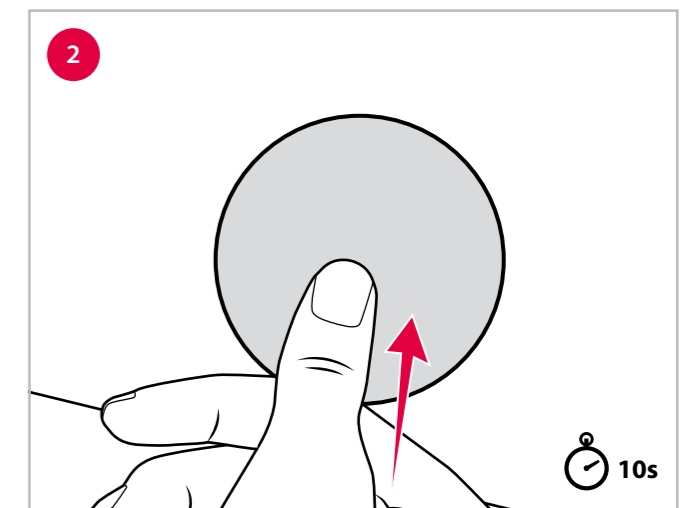
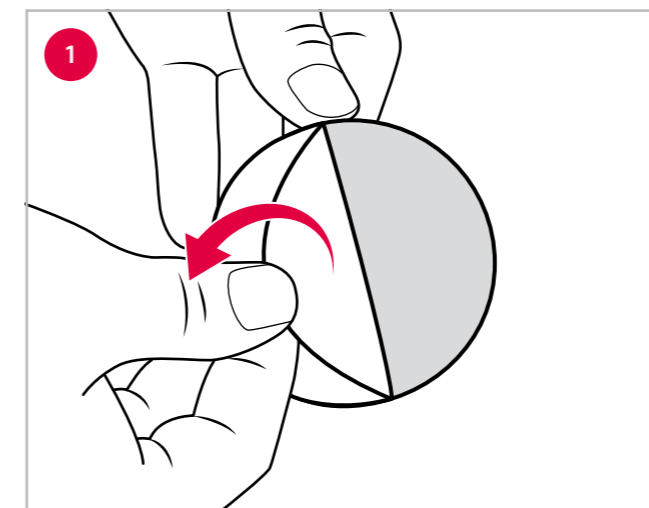



# Visit smoke alarm – ionization

## Overview

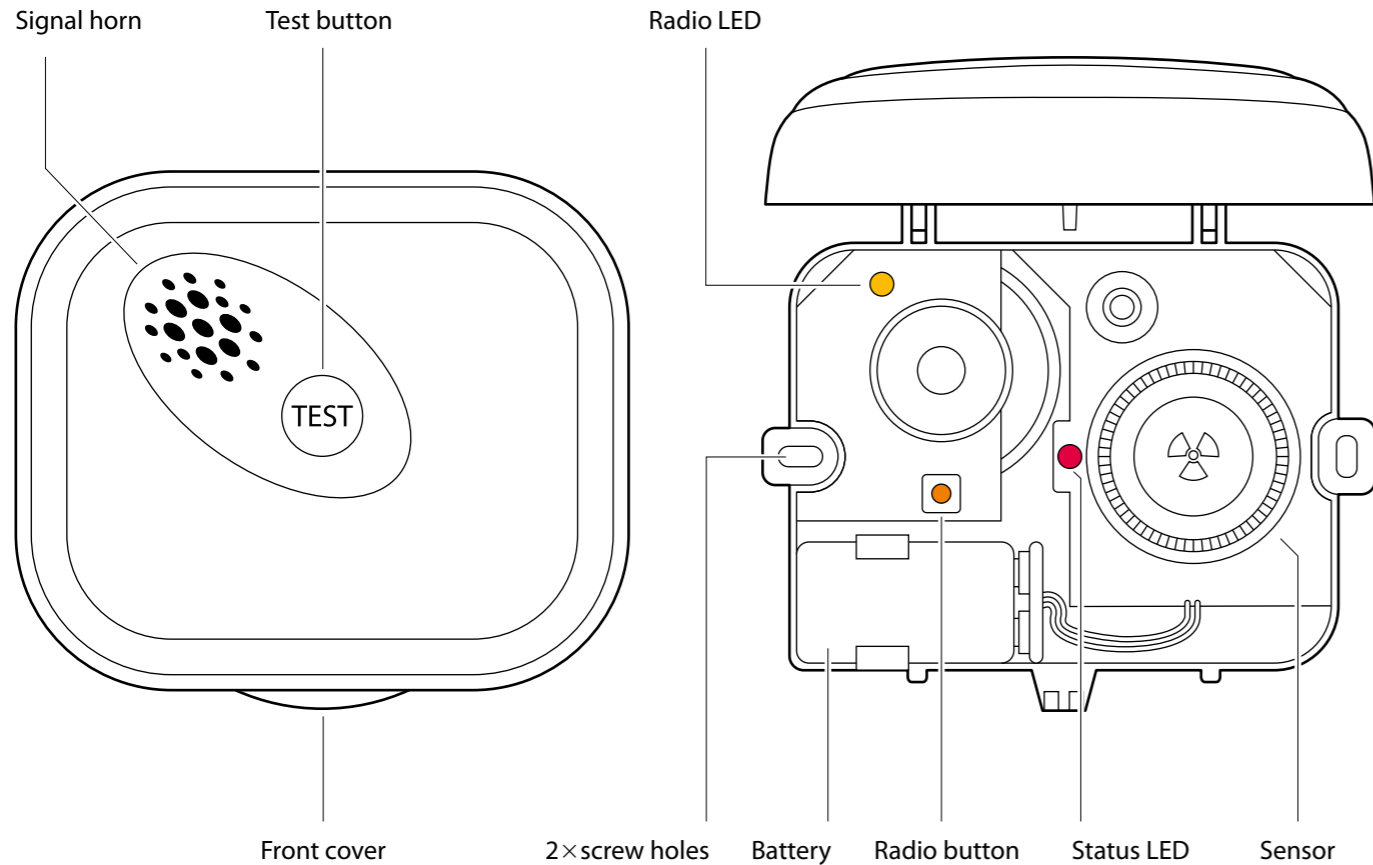

## Technical specifications

### In the box

- BE1551 Visit smoke alarm
- 1 × 9 V alkaline battery
- 2 × screws and plugs
- User manual

### Power and battery

- Battery type  
Duracell MN1604  
9 V alkaline battery
- Power consumption  
Idle position < 15 μA
- Battery life  
Minimum 3 years

### Size and weight

- Height: 118 mm, 4.6"
- Width: 140 mm, 5.5"
- Depth: 42 mm, 1.6"
- Weight: 200 g, 7 oz. incl. battery

### Sensor type

- Ionization smoke detection

### Audible alarm

- Min 85 dB(A) @ 3m (10'), 2.6 kHz

### Activation

- Via the test button
- Via the built-in smoke detector

### Frequency and coverage

- Radio frequency  
868.30 MHz
- Coverage: Up to 200 m (218 yd.), clear line of sight. It depends on the building's characteristics and radio conditions.

### Environment

- For indoor use only
- Operating temperature  
4° till 40° C, 39° to 104° F
- Relative humidity  
15% to 95% RH, non-condensing

### Smoke sensitivity

- Meets the BS EN 14604:2005 standard

## Setting up the smoke alarm

- 1 Remove the front cover by rotating it fully backwards and connect the battery to the battery snaps to start the unit. The alarm will chirp during startup.
- 2 Mark the location of the screw holes and fix the smoke alarm to the ceiling using the supplied screws and plugs. Mount it at least 30 cm, (12") from walls and other obstructions, see **Location and positioning** below.
- 3 Put the cover back on the smoke alarm by pressing gently until it snaps into place.

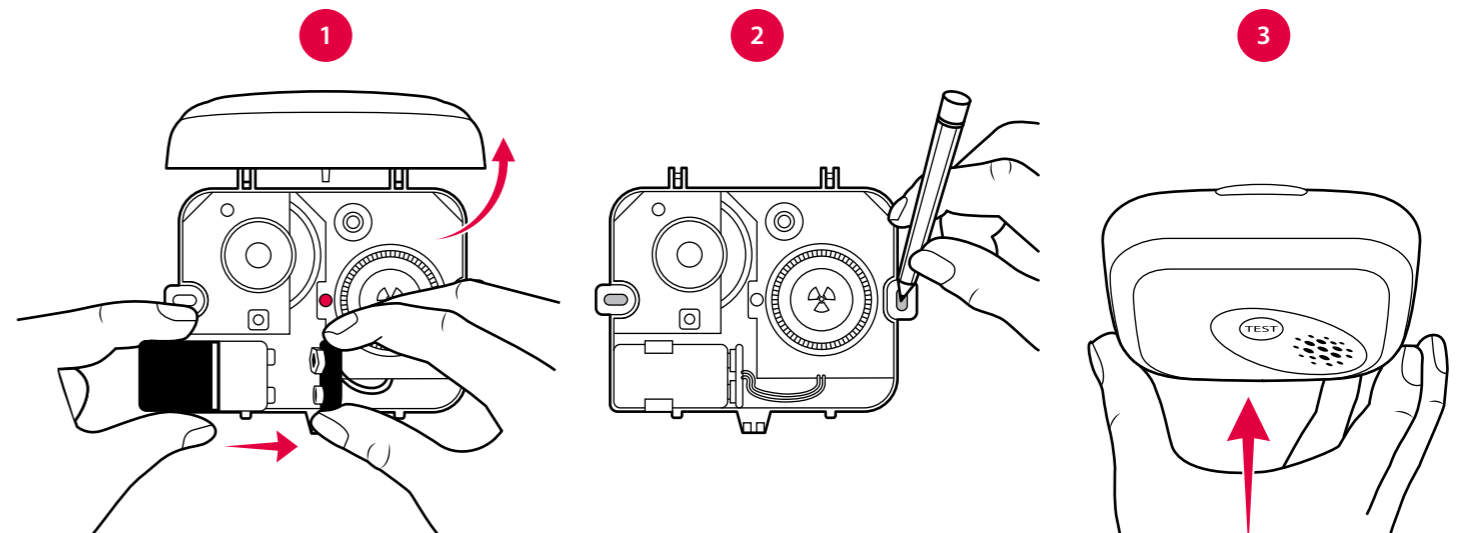

## Location and positioning

Fit the smoke alarms in the center of the ceiling outside the bedrooms, at least 30 cm from any wall. If the bedrooms are in different areas of the house, separate smoke alarms are recommended. In multi-storey properties, install at least one smoke alarm on each floor.

Avoid kitchens, fireplaces or garages, as cooking fumes and car exhaust may cause false alarms. The smoke alarm should not be installed in damp spaces, close to fans, etc. or in agricultural buildings.

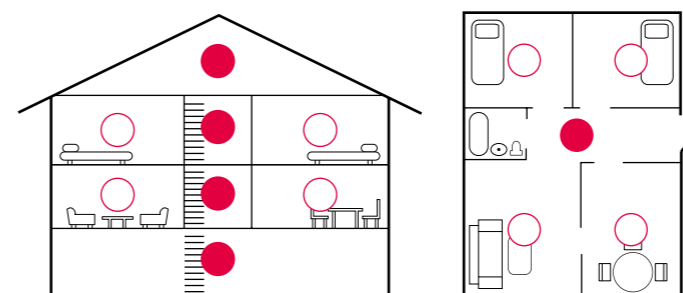

- = Minimum
- = Additional

## Testing the connection

- 1 Press and hold the smoke alarm test button until the alarm sounds. The smoke alarm transmits a radio signal to the receiver.
- 2 The red Visit LED on the receiver lights up to show that the signal was received. In addition, it starts to sound, flash or vibrate depending on the receiver.

**Note:** The smoke alarm will stop sounding shortly after the button is released and the receiver will time out within 40s.

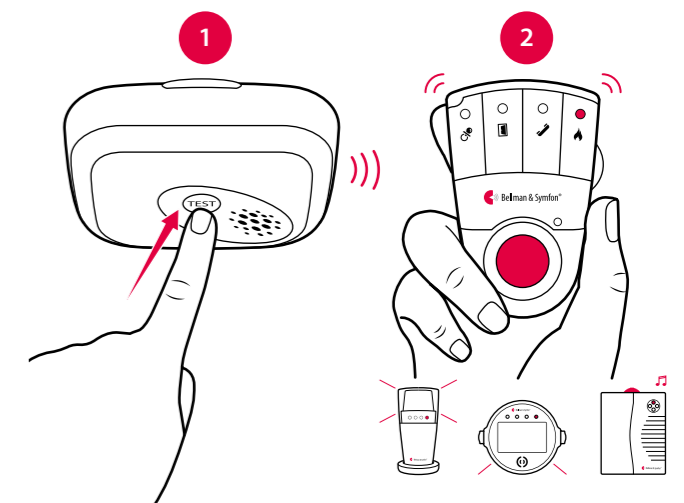



# Visit smoke alarm – ionization

## Signal pattern

The smoke alarm LED blinks in red once per minute to show that it is working correctly. Depending on the alarm, the signal patterns are as follows:

Smoke alarm			Receiver signal pattern			
Alarm type	LED	Sound	Visit LED	Sound	Vibration	Flash
■ Fire detected	Red blinks	Fire alarm	Red blinks	Fire alarm	Long	Yes
■ Low battery	1 red blink / min	1 chirp / min	1 red blink / 5 s	1 short alarm	Short	No

**Note:** When the smoke alarm warns for low battery, you have at least 30 days to replace it. Bed shakers connected to the BE1580 Alarm clock or the BE1441/BE1442 Flash receiver will not vibrate when the smoke alarm battery level is low.

## Using broadcast

If you want the smoke alarm signal to be transmitted to *all* Visit receivers within radio range, you can activate broadcast mode. This will override the radio key settings.

### Here is how you activate broadcast mode:

- 1 Open the smoke alarm front cover to access the radio button, see **Overview**.
- 2 Press the radio button three times in quick succession. The radio LED blinks three times to show that broadcast mode is activated.

**Note:** Battery warnings will only be transmitted to units with the same radio key. To disable broadcast, you need to select a new radio key, see **Changing the radio key** on the following page.

## Test and maintenance

Test the smoke alarm and radio connection regularly, preferably each week, e.g. during cleaning, but at least once per month. Always test it immediately after any holidays or other extended periods of absence. Clean it with a damp cloth. After changing battery, vacuum clean with a soft brush. Do not paint over the smoke alarm.

## Troubleshooting

If	Try this
Nothing happens when I press the smoke alarm test button	<ul style="list-style-type: none"> <li>■ Check that the battery snaps are firmly connected.</li> <li>■ Replace the smoke alarm battery. Only use a Duracell MN1604 alkaline battery.</li> <li>■ Check the age of the unit, see the “replace by” label on the sidewall of the unit.</li> </ul>
The smoke alarm beeps when I press the test button, but the Visit receiver is not responding	<ul style="list-style-type: none"> <li>■ Check the smoke alarm battery and the receiver batteries and connections.</li> <li>■ Move the receiver closer to the smoke alarm to make sure it’s within radio range.</li> <li>■ Check that the units are set to the same radio key, see <b>Changing the radio key</b>.</li> </ul>
The Visit receiver is activated for no apparent reason	<ul style="list-style-type: none"> <li>■ Change the smoke alarm battery if the red Visit LED indicates low battery.</li> <li>■ If the problem persists, there is probably another Visit system nearby that triggers yours. Change the radio key on all units, see <b>Changing the radio key</b>.</li> </ul>
The smoke alarm beeps and chirps for no apparent reason	<ul style="list-style-type: none"> <li>■ Check for fumes or steam from the kitchen or bathroom. Check for any sign of contamination such as cobwebs or dust. If the problem persists, replace the unit.</li> </ul>

## Changing the radio key

If your Visit system is activated for no reason, there is probably a nearby system that triggers yours. In order to avoid radio interference, you need to change the radio key on all units.

### Systems with *different* types of transmitters

Start by changing the radio key on all *other* transmitters in the system by moving any of the radio key switches, see the corresponding user manual. **Note:** All transmitters must be set to the same radio key to operate as a group.

### Changing the radio key on the BE1551 Smoke alarm

- 1 Open the front cover on the BE1551 Smoke alarm to access the radio button, see **Overview**. Press and hold the radio button until the radio LED flashes slowly in yellow. Release the button.
- 2 Press the test button on any *other* transmitter within 30 s to transmit the new radio key.
- 3 The radio LED on the BE1551 Smoke alarm lights up in yellow to show that the radio key has been changed.

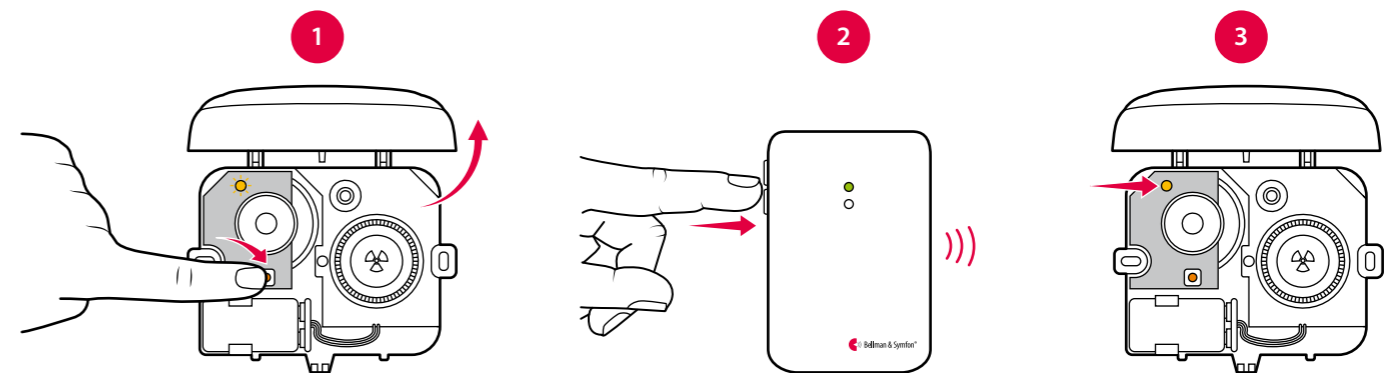

### Changing the radio key on a receiver

- 1 Press and hold the test/function button on the receiver until the green and yellow Visit LEDs blink alternately. Release the button.
- 2 Press the test button on any transmitter within 30 s to transmit the new radio key.
- 3 All Visit LEDs on the receiver blink 5 times to show that the radio key has been changed.

### Systems with *only* BE1551 Smoke alarms

#### Changing the radio key on the smoke alarms

Select one of the BE1551 Smoke alarms that will function as the *master* unit. The other BE1551 Smoke alarm will function as a *slave* unit. Open the front cover on the units to access the radio button, see **Overview**.

- 1 Press and hold the radio button on the *master* unit until the radio LED blinks slowly in yellow. Press and hold the button again to generate a new radio key. The radio LED blinks faster to confirm.
- 2 Press and hold the radio button on the *slave* unit until the radio LED blinks slowly in yellow.
- 3 Press and hold the test button on the *master* unit to transmit the new radio key. The alarm will sound to confirm.
- 4 The radio LED on the *slave* unit lights up in yellow to show that the radio key has been changed.
 

**Note:** Repeat steps 2 - 4 to change the radio key on an additional BE1551 Smoke alarm.

#### Changing the radio key on a receiver

- 1 Press and hold the test/function button on the receiver until the green and yellow Visit LEDs blink alternately. Release the button.
- 2 Press and hold the test button on any smoke alarm within 30 s to transmit the new radio key. The alarm will sound to confirm.
- 3 All Visit LEDs on the receiver blink 5 times to show that the radio key has been changed.



# Visit CO alarm – electrochemical

## Buttons and controls

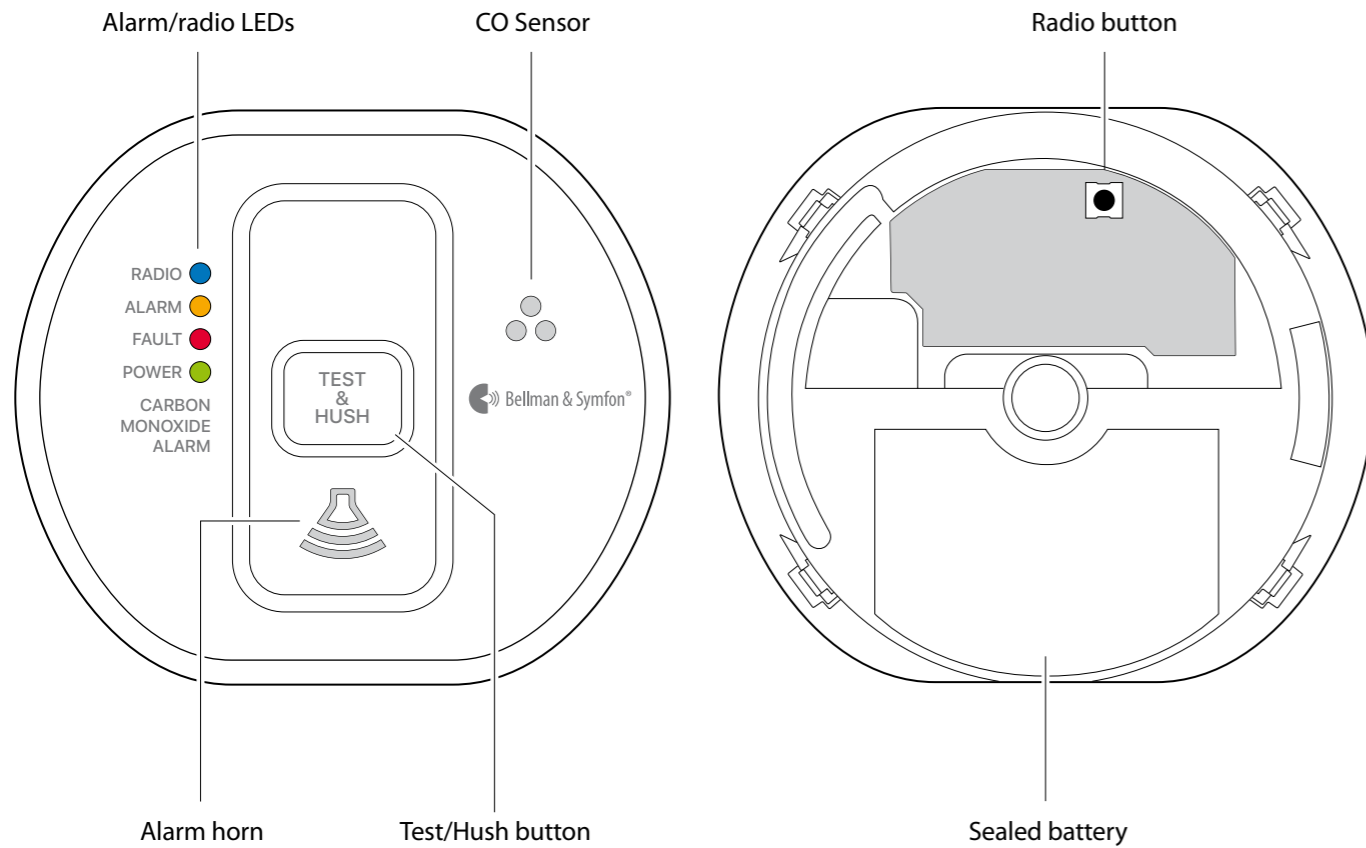

## Technical specifications

### Size and weight

- Height: 105 mm
- Width: 120 mm
- Depth: 40 mm
- Weight: 185 g incl. battery

### Power and battery

- **Battery:** Built-in powered for life non-replaceable lithium battery
- **Battery life:** 10 years. Matches the product lifetime.

### Regulatory

- Meets BS EN 50291-1:2010 and A1:2012 / BS EN 50291-2:2010

### In the box

- BE1555 Visit CO alarm
- Screws and plugs
- User manual

### Activation

- Via the Test/Hush button
- By carbon monoxide

### Frequency and coverage

- Radio frequency : 868.30 MHz
- Coverage: Up to 200 m (218 yd.), clear line of sight. It depends on the building's characteristics and radio conditions.

### Environment

- For indoor use only  
Operating temperature -10° to 40° C
- Humidity range  
15% to 95% R.H. (non-condensing)

### CO alarm response

- BE1555 is calibrated to respond to the following levels of carbon monoxide:

CO level/fault	Alarm sound
> 43 ppm	On within 60 – 90 min.
> 80 ppm	On within 10 – 40 min.
>150 ppm	On within 2 minutes
Low battery	1 beep every minute
Faulty unit	2 beeps every minute
End of life	3 beeps every minute

## Installing the CO alarm

- 1 Remove the mounting bracket from the CO alarm by turning it counter-clockwise.
- 2 Taking care to avoid any electrical wiring, fix the mounting bracket to the ceiling or wall using the supplied screws and plugs, see **Location and positioning** below.
- 3 Fit the alarm to the bracket by turning it clockwise until it snaps into place. The red, yellow and green LEDs blink in sequence to show that the unit is on.

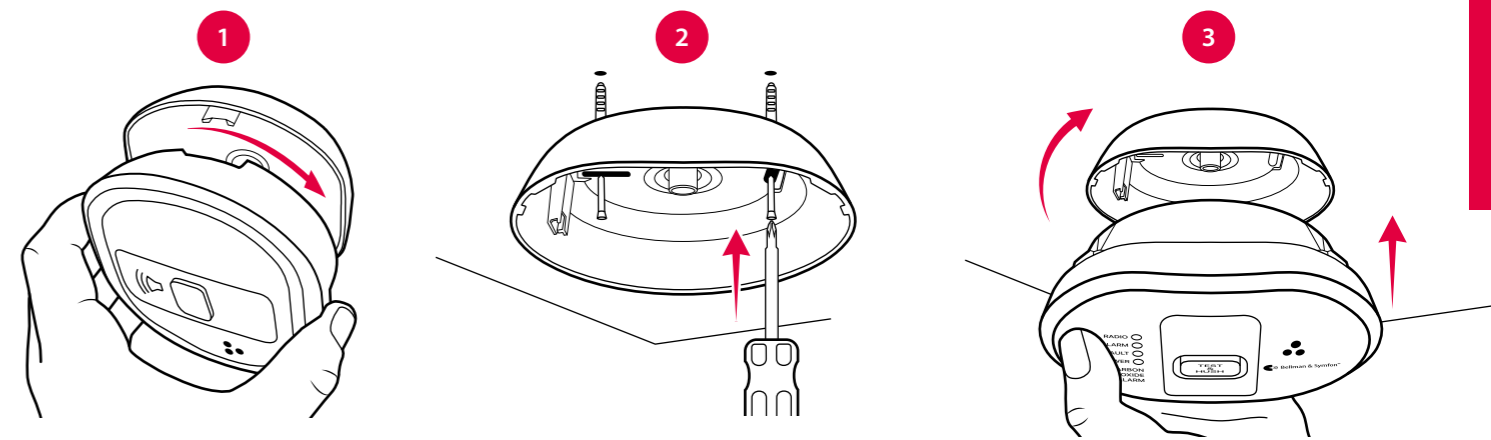

## Location and positioning

Install the CO alarms in every bedroom, in every room containing a fuel burning appliance and in remote rooms where occupants spend a considerable amount of time. Fit the alarms in the center of the ceiling inside every bedroom, at least 30 cm (11.8") from any wall or light fitting.

Avoid kitchens, fireplaces or garages, as cooking fumes and car exhaust may cause false alarms. The CO alarm should not be installed in damp spaces, close to fans, etc. or in agricultural buildings.

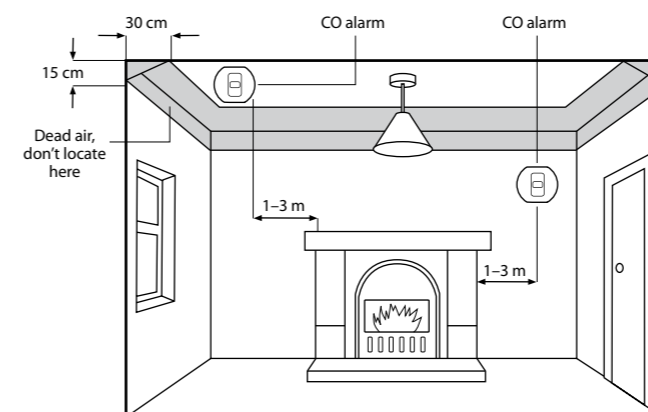

## Testing the connection

- 1 Wait 15 s. Press the test/hush button and release it when the alarm sounds. The CO alarm transmits a radio signal to the receiver.
- 2 The orange and red LEDs on the Visit receiver blink alternately to show that the signal was received. In addition, it starts to sound, flash or vibrate depending on the receiver.

**Note:** The alarm will stop sounding after the button is released and the Visit receiver will time out in less than a minute.

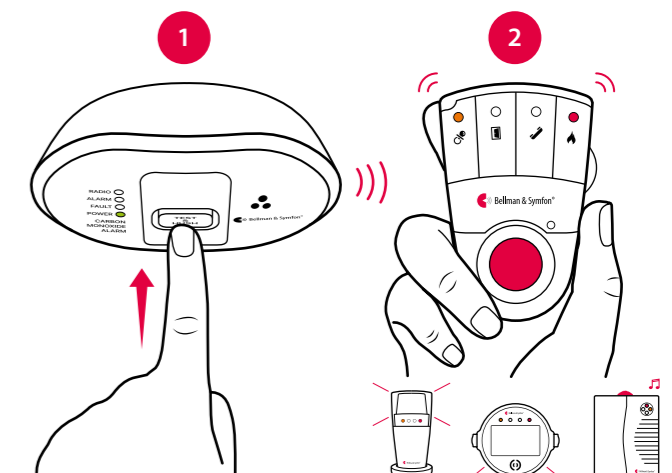

# Visit CO alarm – electrochemical

## Signal pattern

When the alarm detects over 43 ppm CO, the red LED blinks in accordance with the table. This helps locate CO leaks as the alarm gives an indication straight away. This pre-alarm signal may be triggered by CO coming from e.g. cooking with gas, car engines or nearby barbecues. This is usually not a concern, unless the pre-alarm signal persists until the alarm sounds and the CO source is unknown. **Note:** The alarm may sound if cigarette smoke is blown into it, or aerosols are released nearby. Depending on the cause of the alarm, the signal patterns are as follows:

CO level / fault	Alarm LED	Alarm sound	Visit receiver
▪ > 43 ppm	1 red blink every 2 s	On within 60 - 90 min	Alarm within 60 - 90 min
▪ > 80 ppm	2 red blinks every 2 s	On within 10 - 40 min	Alarm within 10 - 40 min
▪ >150 ppm	4 red blinks every 2 s	On within 2 min	Alarm within 2 min
▪ Low battery	1 yellow blink / min	1 beep / min	Blinking red LED
▪ Faulty unit	2 yellow blinks / min	2 beeps / min	Blinking red LED
▪ End of Life	3 yellow blinks / min	3 beeps / min	Blinking red LED

**Note:** When the low battery warning occurs for the first time, you have at least 30 days to replace the unit. You can press the test/hush button to temporarily hush the low battery warning for 24 hours.

## Using broadcast

If you want the smoke alarm signal to be transmitted to *all* Visit receivers within radio range, you can activate broadcast mode. This will override the radio key settings.

- To activate broadcast, remove the CO alarm from the bracket to access the radio button, see **Buttons and controls**. Press the radio button three times in quick succession. The radio LED blinks three times in blue to show that broadcast is activated.

## Silencing (Hush)

- When the alarm sounds, after sensing CO, pressing the test/hush button will immediately stop the horn (the red LED will continue to blink). If CO is still present, the horn will turn on again after about 4 minutes. The CO alarm can only be silenced once during a CO incident. At levels > 150ppm CO the unit cannot be silenced.

## Test and maintenance

Test the CO alarm and radio connection regularly, at least once per month. Always test it immediately after any holidays or other extended periods of absence. Clean the outside case with a clean damp cloth. Avoid spraying air fresheners, hair spray, paint or other aerosols near the CO alarm. Do not place air fresheners near the CO alarm. Do not paint over the CO alarm.

## Troubleshooting

If	Try this
The CO alarm beeps for no apparent reason.	<ul style="list-style-type: none"> <li>▪ Follow the detailed instructions in <b>What to do when the alarm sounds</b> section in the BE1555 User manual.</li> </ul>
The Visit receiver is triggered for no apparent reason.	<ul style="list-style-type: none"> <li>▪ There is probably another Visit system nearby that triggers yours. Change the radio key on all units, see <b>Changing the radio key</b>.</li> </ul>
Nothing happens when I press the CO alarm test/hush button.	<ul style="list-style-type: none"> <li>▪ Check that the unit is secured correctly on the mounting plate. Wait 15 s before testing again by pushing the test/hush button.</li> <li>▪ Check the age of the alarm, see the “replace by” label on the unit.</li> </ul>
The CO alarm beeps when I press the test/hush button, but the Visit receiver is not responding.	<ul style="list-style-type: none"> <li>▪ Check the Visit receiver batteries and connections.</li> <li>▪ Move the receiver closer to the CO alarm to make sure it's within radio range.</li> <li>▪ Check that the units are set to the same radio key, see <b>Changing the radio key</b>.</li> </ul>

## Changing the radio key

If your Visit system is activated for no reason, there is probably a nearby system that triggers yours. In order to avoid radio interference, you need to change the radio key on all units. The procedure differs depending on your system setup.

### Systems with different types of transmitters

Start by changing the radio key on all *other* transmitters in the system by moving any of the radio key switches, see the corresponding user manual. **Note:** All transmitters must be set to the same radio key to operate as a group.

#### Step 1: Change the radio key on the BE1555 CO alarm

- 1 Remove the alarm from the bracket to access the radio button, see **Buttons and controls**. Press and hold the radio button until the radio LED blinks slowly in blue. Release the button.
- 2 Press the test button on any *other* transmitter within 30 s to transmit the new radio key.
- 3 The radio LED on the alarm lights up in blue to show that the radio key has been changed.

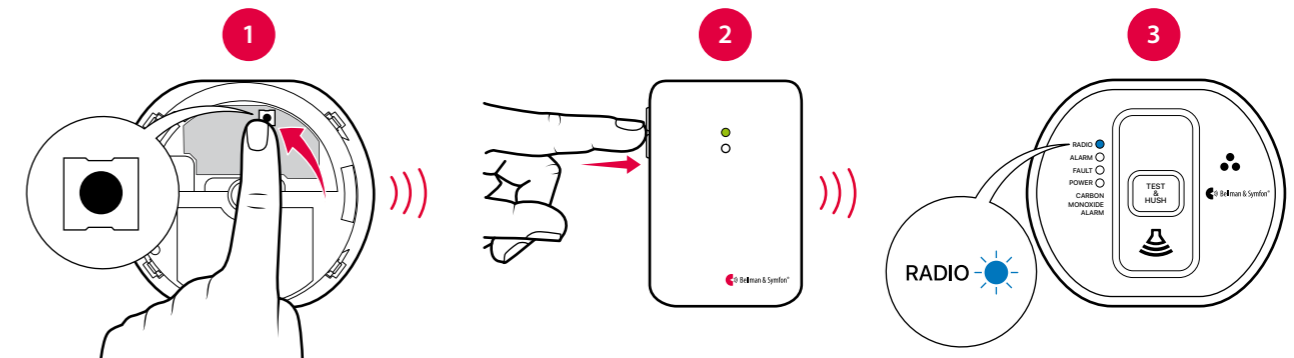

### Systems with only BE1555 CO alarms

#### Step 1: Change the radio key on the BE1555 CO alarms

Select one of the BE1555 CO alarms that will function as the *master* unit. The other alarms will function as slave units. Remove the CO alarms from the brackets to access the radio button.

- 1 Press and hold the radio button on the *master* unit until the radio LED blinks slowly in blue. Press and hold the button again to generate a new radio key. The radio LED will pulsate to confirm.
- 2 Press and hold the radio button on the *slave* unit until the radio LED blinks slowly in blue.
- 3 Press the test/hush button on the *master* unit and release it when the alarm sounds to transmit the new radio key.
- 4 The radio LED on the *slave* unit lights up in blue to show that the radio key has been changed. Repeat steps 2 - 4 to change the radio key on an additional BE1555 CO alarm.

#### Step 2: Change the radio key on the Visit receiver

- 1 Press and hold the test button on the receiver until the green and yellow Visit LEDs blink alternately. Release the button.
- 2 Within 30 s, press the test/hush button and release it when the alarm sounds to transmit the new radio key.
- 3 All Visit LEDs on the receiver blink 5 times to show that the radio key has been changed.

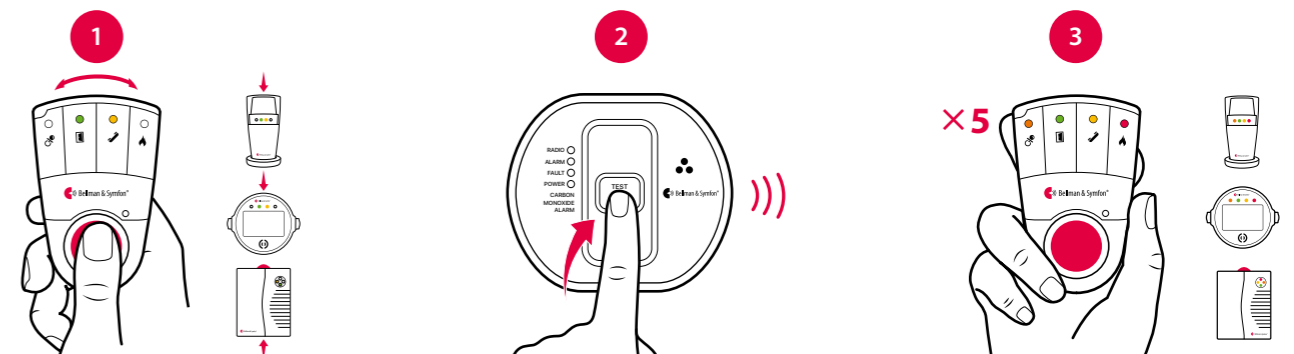



# Visit flash receiver

## Buttons and controls

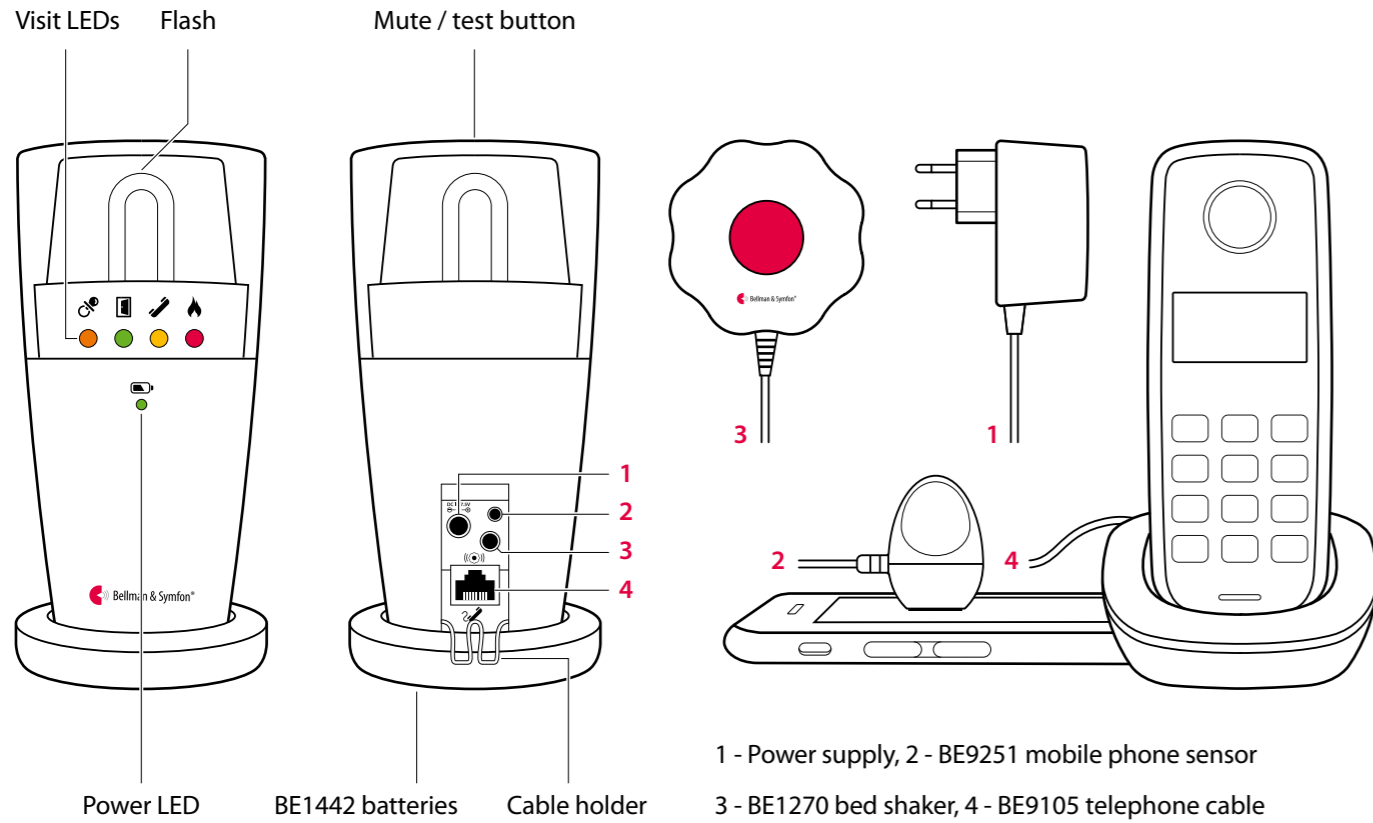

## Technical specifications

### In the box

- BE1441 Flash receiver or BE1442 Flash receiver w. battery backup
- Power supply
- 4 × 1.2 V AAA NiMH batteries (BE1442 model only)

### Power and battery

- Mains power  
7.5 V DC / 1500 mA  
External power supply unit
- Power consumption  
Active: 1250 mA, idle position: 10 mA
- Backup batteries (BE1442 model only)  
4 × 1.2 V AAA NiMH rechargeable batteries
- Backup battery operating time  
~ 48 h when fully charged

### Dimensions and weight

- Height BE1441: 140 mm, 5.5"  
BE1442: 155 mm, 6.1"
- Diameter BE1441: 70 mm, 2.7"  
BE1442: 78 mm, 3.1"
- Weight 310 g, 10.9 oz.

### Visit LEDs

The Visit LEDs normally indicates the following:

- Orange LED, pacifier symbol  
The baby monitor is activated
- Green LED, door symbol  
The door transmitter is activated
- Yellow LED, telephone symbol  
The phone transmitter is activated
- Red LED, fire symbol  
The smoke alarm is activated

### Accessories

- BE9075 Wall bracket
- BE1270 Bed shaker
- BE9251 Mobile phone sensor
- BE9105 Telephone cable

### Frequency and coverage

- Radio frequency  
314.91 MHz, 433.92 MHz or 868.30 MHz, depending on the region
- Coverage  
50 – 250 m, 55 - 273 yd. depending on the radio frequency and the characteristics of the building

### Output

- Built-in ~30 Candela Xenon light  
Warning! Flashes can cause epileptic attacks

## Getting started

- Connect the power supply to the receiver and the mains outlet. Pull the battery tab on the bottom (BE1442 only). Place the receiver on a level surface or mount it on the wall using the wall bracket accessory (see separate instructions).
- To test the radio link you need a Visit transmitter. Press the test button/s on the transmitter.
- The receiver lights up a Visit LED and starts to flash. If a bed shaker is connected, it will vibrate. A short press on the mute/test button repeats the last indication. If nothing happens, see **Troubleshooting**.

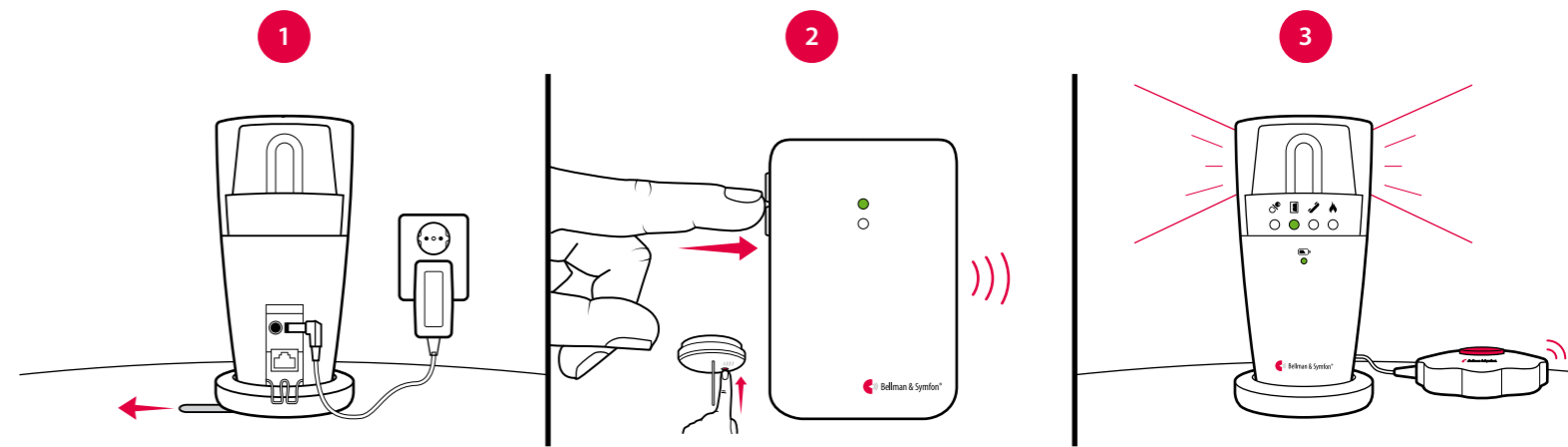

## Default signal pattern

When a transmitter is activated, the flash receiver lights up an LED, flashes and the bed shaker starts to vibrate with a certain pace. This is called signal pattern. The transmitters determine the pattern, and the default is as follows:

Transmitter	Flash receiver	Bed shaker
<b>Activated source</b>	<b>Visit LED</b>	<b>Vibration</b>
Door transmitter / push button transmitter	Green	Slow ■□□□
Telephone transmitter / connected telephone	Yellow	Medium ■■□□
Baby monitor	Orange	Fast ■■■■■■
Smoke alarm	Red	Long ■■■■□

## Changing the signal pattern

The signal pattern can only be changed on the transmitters. See **Changing the signal pattern** for the relevant transmitter.

## Power LED indications

When the flash receiver is connected to mains power, the power LED lights up in green. The BE1442 model is also equipped with battery backup and the power LED indicates the following:

### Power LED

- Green light
- Green blinks
- Red light
- Red blinks

### Status

- The flash receiver is connected to mains power. The backup batteries are detected.
- The flash receiver is connected to mains power. No backup batteries are detected.
- The flash receiver is running on battery backup.
- The backup batteries are nearly depleted.



# Visit flash receiver

## Changing the radio key

If your Visit system is activated for no reason, there is probably a nearby system that triggers yours. In order to avoid radio interference, you need to change the radio key on all units. The radio key switches are located on the **transmitters**.

**Here is how you change the radio key:**

- 1 Open the transmitter cover and move any radio key switch to the up (on) position to change the radio key. See **Changing the radio key** for the relevant transmitter.
- 2 Press and hold the mute/test button on the top of the receiver until the green and yellow Visit LEDs blink alternately. Release the button.
- 3 Press the test button/s on the transmitter within 30 seconds to send the new radio key.
- 4 All Visit LEDs on the receiver blink 5 times to show that the radio key has been changed. It then returns to normal mode.

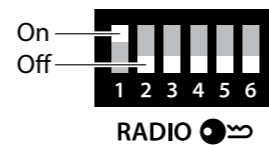

**Note:** All Visit units must be set to the same radio key in order to operate as a group.

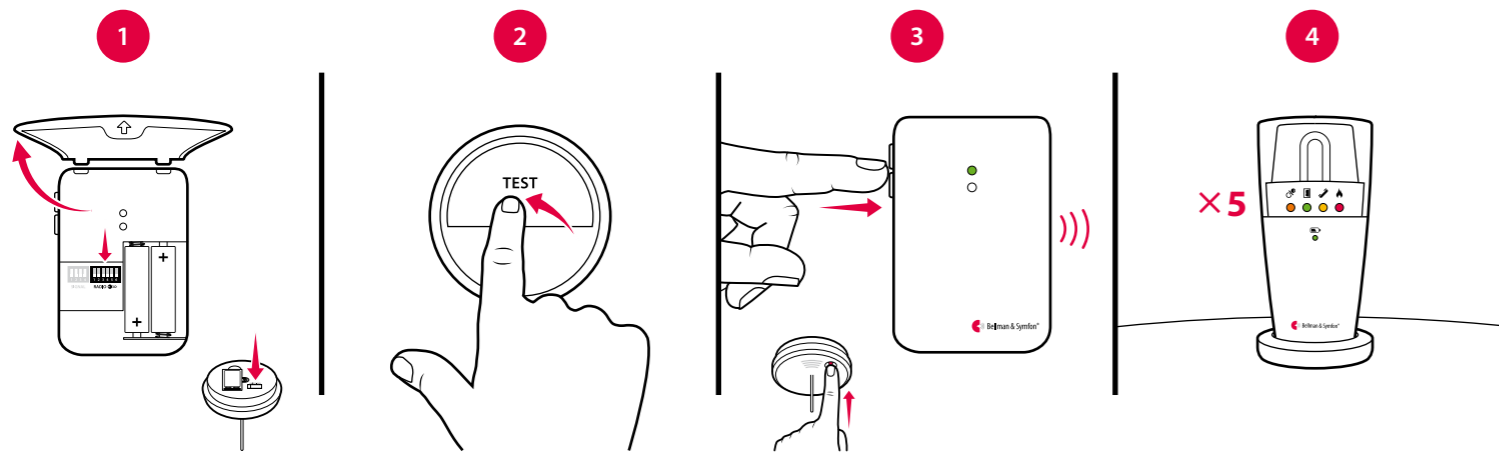

## Accessories

The flash receiver can be complemented with the following accessories:

- **BE1270 Bed shaker**  
Wakes you with vibrations under the pillow or mattress.
- **BE9250 Mobile phone sensor**  
Place it on the mobile phone or tablet, and the flash receiver will alert you of incoming calls and messages.
- **BE9105 Telephone cable**  
Use it to connect the receiver to your landline telephone and be alerted with flashes when the phone rings.
- **BE9075 Wall bracket**

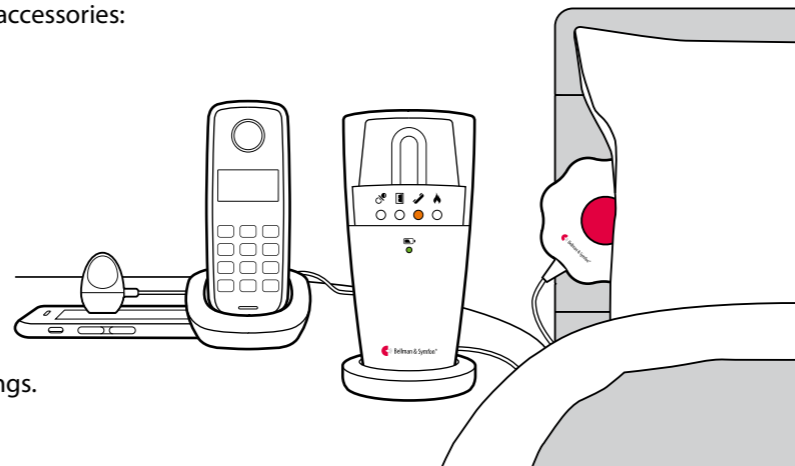

## Directing the flash

The flash receiver features a rotating top that makes it easy to direct the light. Point it for example towards a wall if you feel that the flash is too intense. A silicone slip-on top is also available in a variety of colours (art. no. BE9164-BE9167).

## Advanced programming

By using advanced programming, you can customize the signal pattern from a specific transmitter and event, displaying the LED colour and vibration pattern of your choice. The advanced programming overrides the radio key and pairs the units via the serial number. Please note that smoke- and CO alarms cannot be programmed for safety reasons.

**Note:** The transmitter must be activated as it is intended to be used in the system to generate the right signal. This means that you can't always use the transmitter test button (see **Default signal pattern** for the relevant transmitter).

**Here is how you program the receiver:**

- 1 Press and hold the mute/test button on the receiver. The green and yellow Visit LEDs will start to blink alternately. While still holding down the button, activate the desired transmitter as intended. Release the button.
- 2 Scroll through the different **Visit LED options** by pressing the mute/test button on the receiver. Select the desired Visit LED colour by holding down the mute/test button until the power LED goes out and lights up again.
- 3 Scroll through the different **vibration options** by pressing the test button on the receiver (bed shaker required). Select the desired vibration pattern by holding down the mute/test button until the power LED goes out and lights up again.
- 4 The receiver will now show the new Visit LED colour and vibration pattern. Press the mute/test button briefly to end the demonstration. After a short while, it will return to normal mode.

## Deleting the advanced programming

Follow the procedure below to delete the advanced programming.

- 1 Hold down the mute/test button on the receiver until the green and yellow Visit LEDs blink alternately. Release the button.
- 2 Press the mute/test button on the receiver 3 times in quick succession.
- 3 All Visit LEDs will light up for ~2 seconds to show that it has been deleted.

## Troubleshooting

Most problems with the flash receiver can be solved quickly by following the advice below.

If	Try this
The receiver seems to be turned off	<ul style="list-style-type: none"> <li>▪ Check that the power supply is connected correctly.</li> <li>▪ Charge the backup batteries for at least 24 hours (BE1442 only).</li> </ul>
The power LED blinks in red	<ul style="list-style-type: none"> <li>▪ The backup batteries are nearly depleted and the power supply is disconnected. Connect the power supply and charge the batteries for at least 24 hours.</li> </ul>
The power LED blinks in green	<ul style="list-style-type: none"> <li>▪ The receiver detects no backup batteries. Pull the battery tab, see <b>Getting started</b>.</li> </ul>
The receiver does not respond when a transmitter is activated, but works when I use the test button	<ul style="list-style-type: none"> <li>▪ Check the transmitter batteries and connections.</li> <li>▪ Move the receiver closer to the transmitter to make sure it's within radio range.</li> <li>▪ Check that the receiver is set to the same radio key as the other units in the Visit system, see <b>Changing the radio key</b>.</li> </ul>
The receiver is activated for no apparent reason	<ul style="list-style-type: none"> <li>▪ There is probably another Visit system installed nearby that triggers your system. Change the radio key on all units, see <b>Changing the radio key</b>.</li> </ul>
The flash is too bright	<ul style="list-style-type: none"> <li>▪ Redirect the light by rotating the top or use a silicone slip-on top to dim the light.</li> </ul>



# Visit portable receiver



BE1450 | BE1452

## Buttons and controls

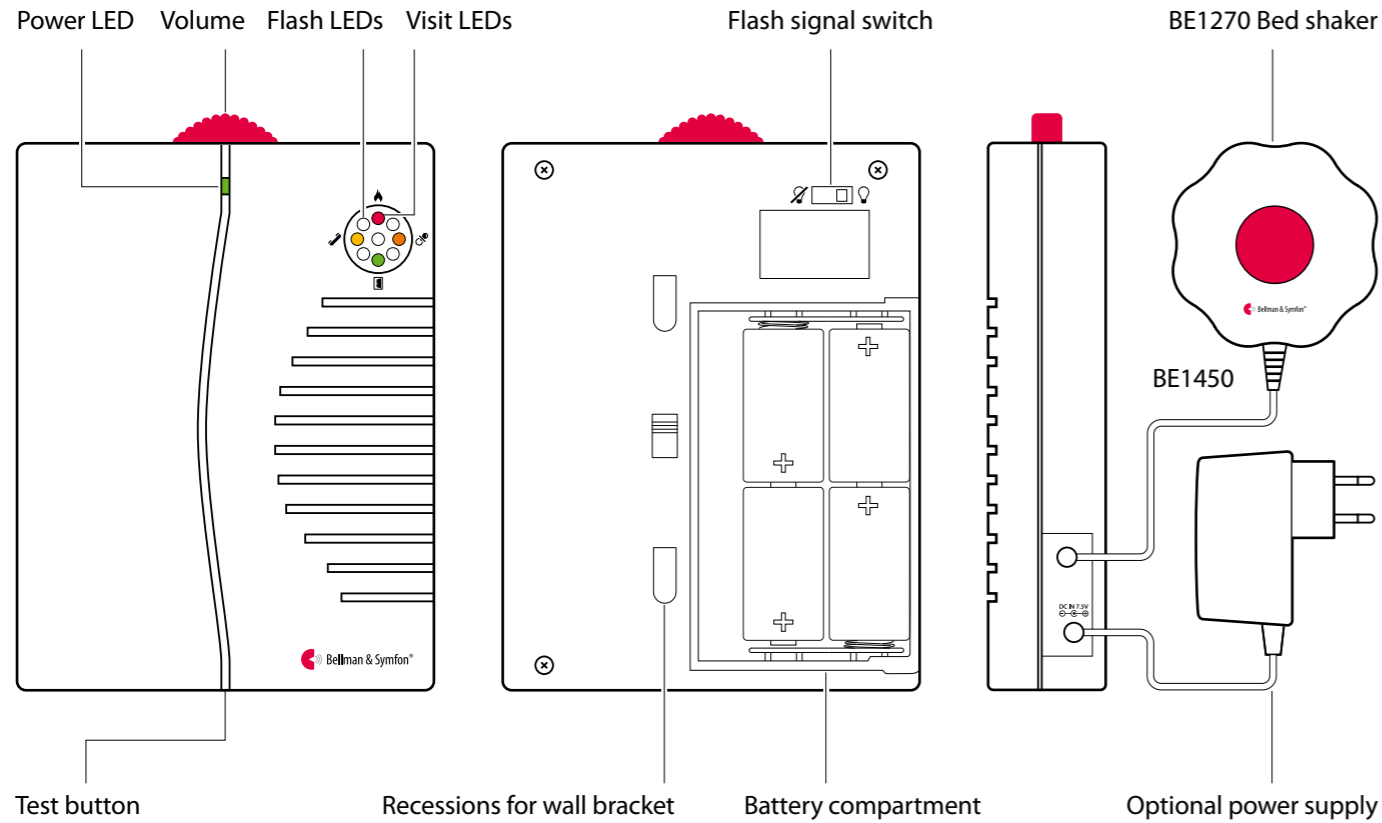

## Technical specifications

### In the box

- BE1450 Portable receiver
- 4 × 1.5V LR14 batteries
- Wall bracket
- Screws and wall plugs

### Power and battery

- Mains power  
7.5 V DC / 1000 mA  
Optional power supply unit  
Europe: BE9275 + BE9268  
UK: BE9268 + BE9276
- Battery power  
4 × 1.5 V LR14 alkaline batteries
- Operating time  
2 – 3 years with alkaline batteries
- Power consumption  
Active: 1000 mA  
Idle position: 0.1 mA

### Dimensions and weight

- Height: 165 mm, 6.5"
- Width: 130 mm, 5.1"
- Depth: 36 mm, 1.5"
- Weight: 590 g, 20.8 oz. incl. batteries

### Visit LEDs

The Visit LEDs normally indicates the following:

- Orange LED, pacifier symbol  
The baby monitor is activated
- Green LED, door symbol  
The door transmitter is activated
- Yellow LED, telephone symbol  
The phone transmitter is activated
- Red LED, fire symbol  
The smoke alarm is activated

### Output

- Adjustable sound signal  
Max 93 dBA @ 1 m, frequency range: 500 – 1000 Hz
- Bed shaker outlet: 2.0 – 4.0 VDC or  
Speaker outlet: 10 kΩ, 0 – 4 V

### Frequency and coverage

- Radio frequency  
314.91 MHz, 433.92 MHz or 868.30 MHz, depending on the region
- Coverage  
50 – 250 m, 55 - 273 yd. depending on the radio frequency and the characteristics of the building

### Accessories

- BE1270 Bed shaker
- Power supply unit,  
Europe: BE9275 + BE9268  
UK: BE9268 + BE9276

## Getting started

- Slide open the battery cover, fit the batteries and close the cover again. Place the receiver on a level surface or mount it on the wall using the wall bracket.
- To test the radio link you need a Visit transmitter. Press the test button/s on the transmitter.
- The receiver lights up a Visit LED and starts to flash and sound. If a bed shaker is connected, it will vibrate. A short press on the test button repeats the last indication. If nothing happens, see **Troubleshooting**.

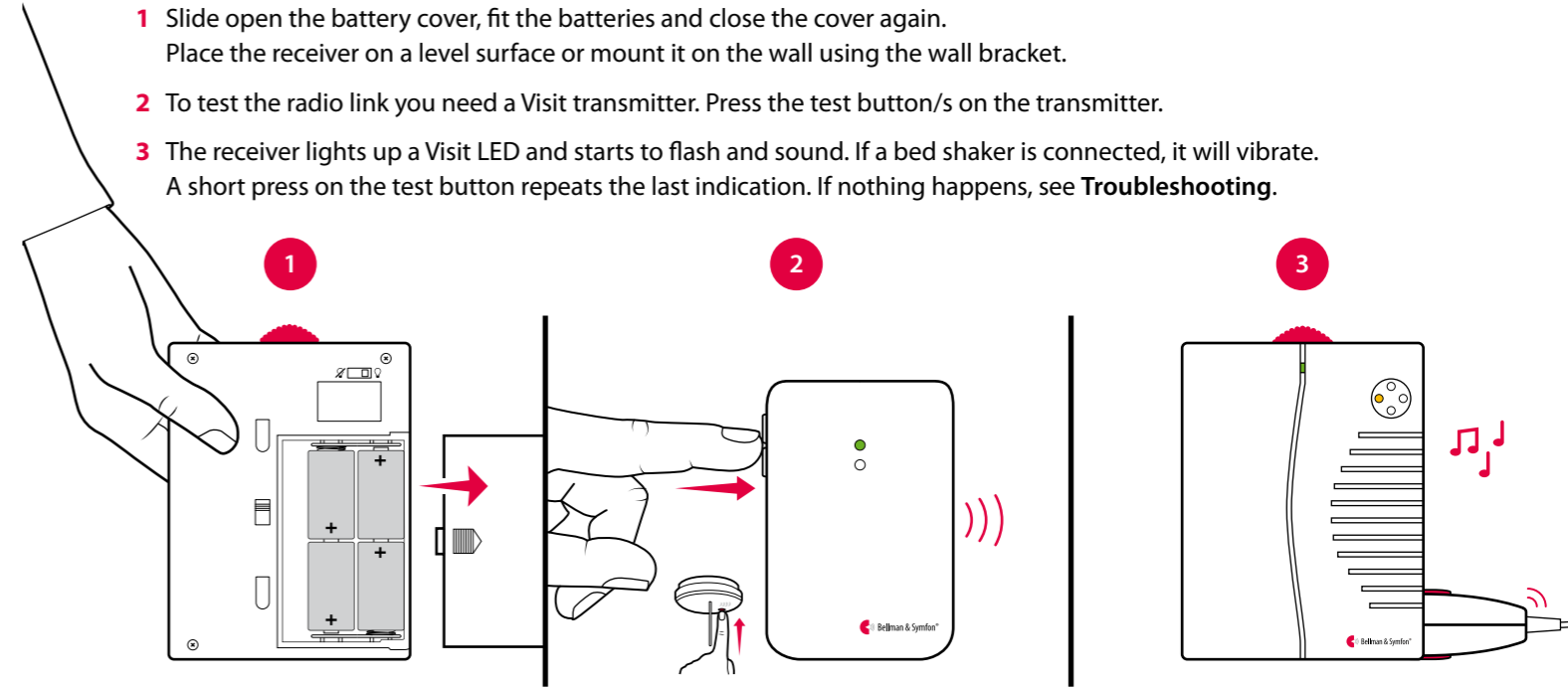

## Default signal pattern

When a transmitter is activated, the receiver lights up an LED, sounds, flashes and the bed shaker starts to vibrate with a certain pace. This is called signal pattern. The transmitters determine the pattern, and the default is as follows:

Transmitter	Portable receiver			Bed shaker
Activated source	Visit LED	Sound	Flash	Vibration
Door transmitter / push button transmitter	Green	Door chime	Yes	Slow ■■■■
Telephone transmitter	Yellow	Ring signal	Yes	Medium ■■■■
Baby monitor	Orange	Baby melody	Yes	Fast ■■■■
Smoke alarm	Red	Fire horn	Yes	Long ■■■■

## Changing the signal pattern

The signal pattern can only be changed on the transmitters. See **Changing the signal pattern** for the relevant transmitter.

## Adjusting the volume and flash

Adjust the volume to your liking using the red volume dial on the top of the receiver. It goes from 0 to 93 dBA @ 1 m with a main frequency range of 500 – 1000 Hz. Use the flash signal switch on the back of the receiver to turn the flash off/on.

## Replacing batteries

If the power LED is yellow when the receiver is activated, the batteries are nearly depleted. Here is how you replace them:

- Slide open the battery cover. Replace the old batteries with four new 1.5 V LR14 alkaline batteries, see the battery compartment for correct positioning.



# Visit portable receiver

## Changing the radio key

If your Visit system is activated for no reason, there is probably a nearby system that triggers yours. In order to avoid radio interference, you need to change the radio key on all units. The radio key switches are located on the **transmitters**.

### Here is how you change the radio key:

- 1 Open the transmitter cover and move any radio key switch to the up (on) position to change the radio key. See **Changing the radio key** for the relevant transmitter.
- 2 Press and hold the test button located on the bottom of the portable receiver until the green and yellow Visit LEDs blink alternately. Release the button.
- 3 Press the test button/s on the transmitter within 30 seconds to send the new radio key.
- 4 All Visit LEDs on the receiver blink 5 times to show that the radio key has been changed. It then returns to normal mode.

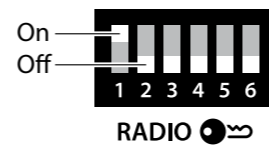

**Note:** All Visit units must be set to the same radio key in order to operate as a group.

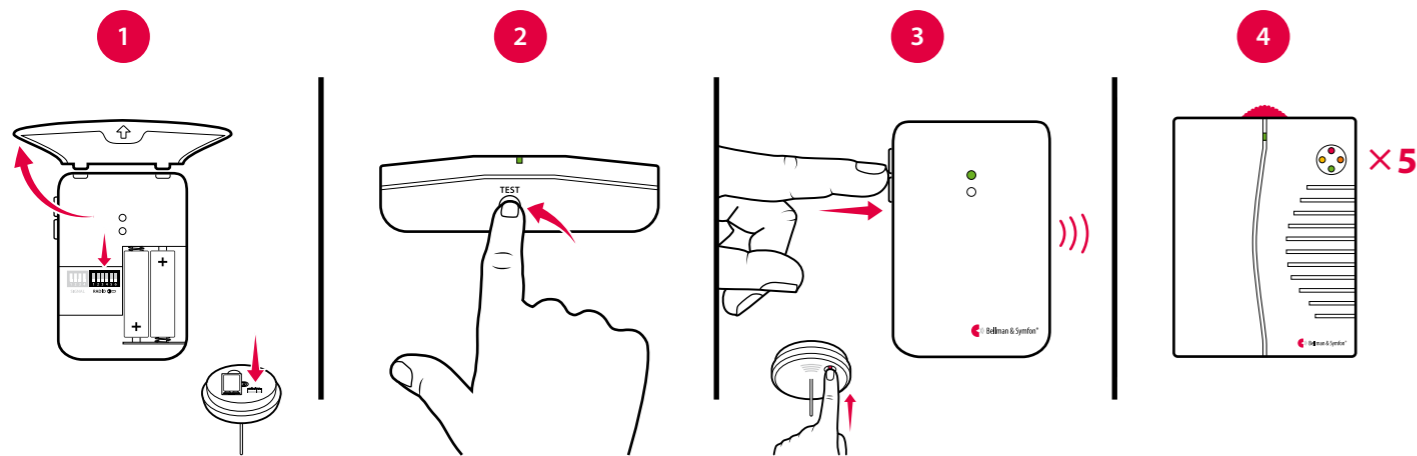

## Accessories

The portable receiver can be complemented with the following accessories:

### ■ BE1270 Bed shaker

Wakes you with vibrations if anything happens while you are asleep. Connect it to the receiver and slide it under your pillow or mattress.

### ■ BE9275 + BE9268 EU / BE9268 + BE9276 UK power supply

If your receiver has a fixed place, you can connect it to mains power and not having to worry about batteries.

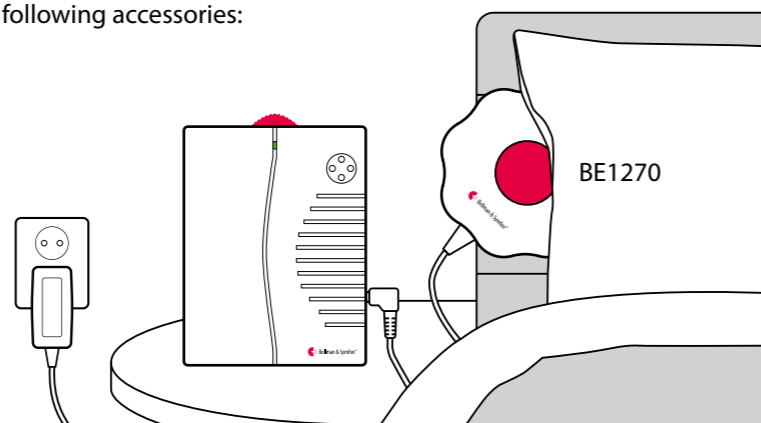

## Advanced programming

By using advanced programming, you can customize the signal pattern from a specific transmitter and event, displaying the LED colour, sound and vibration pattern of your choice. The advanced programming overrides the radio key and pairs the units via the serial number. Please note that smoke alarms cannot be programmed for safety reasons.

**Note:** The transmitter must be activated as it is intended to be used in the system to generate the right signal. This means that you can't always use the transmitter test button (see **Default signal pattern** for the relevant transmitter).

### Here is how you program the receiver:

- 1 Press and hold the test button on the receiver. The green and yellow Visit LEDs will start to blink alternately. While still holding down the button, activate the desired transmitter as intended. The power LED on the receiver will light up in yellow to show that you are in advanced programming mode. Release the button.
- 2 Scroll through the different **Visit LED options** by pressing the test button on the receiver. Select the desired Visit LED colour by holding down the test button until the power LED goes out and lights up again.
- 3 Scroll through the different **sound options** by pressing the test button on the receiver. Select the desired sound by holding down the test button until the power LED goes out and lights up again.
- 4 Scroll through the different **vibration options** by pressing the test button on the receiver (bed shaker required). Select the desired vibration pattern by holding down the test button until the power LED goes out and lights up again.
- 5 The receiver will now show the new Visit LED colour, sound and vibration pattern. Press the test button briefly to end the demonstration. After a short while, it will return to normal mode.

## Deleting the advanced programming

Follow the procedure below to delete the advanced programming.

- 1 Hold down the test button on the receiver until the green and yellow Visit LEDs blink alternately. Release the button.
- 2 Press the test button on the receiver 3 times in quick succession.
- 3 All Visit LEDs will light up for ~2 seconds to show that it has been deleted.

## Troubleshooting

If	Try this
The receiver seems to be turned off	<ul style="list-style-type: none"> <li>■ The batteries are depleted. Replace them with 4 × 1.5V LR14 alkaline batteries.</li> </ul>
The power LED is yellow when the receiver is activated.	<ul style="list-style-type: none"> <li>■ The battery level is low. Replace them with 4 × 1.5V LR14 alkaline batteries.</li> </ul>
The receiver does not respond when a transmitter is activated, but works when I use the test button	<ul style="list-style-type: none"> <li>■ Check the transmitter batteries and connections.</li> <li>■ Move the receiver closer to the transmitter to make sure it's within radio range.</li> <li>■ Check that the receiver is set to the same radio key as the other units in the Visit system, see <b>Changing the radio key</b>.</li> </ul>
The receiver is activated for no apparent reason	<ul style="list-style-type: none"> <li>■ There is probably another Visit system installed nearby that triggers your system. Change the radio key on all units, see <b>Changing the radio key</b>.</li> </ul>
The receiver is too quiet	<ul style="list-style-type: none"> <li>■ Turn up the volume using the red volume dial on the top of the unit.</li> </ul>
The receiver is not flashing	<ul style="list-style-type: none"> <li>■ Check that the flash signal switch on the back of the unit is set to the ON position.</li> </ul>

# Visit pager receiver

## Buttons and controls

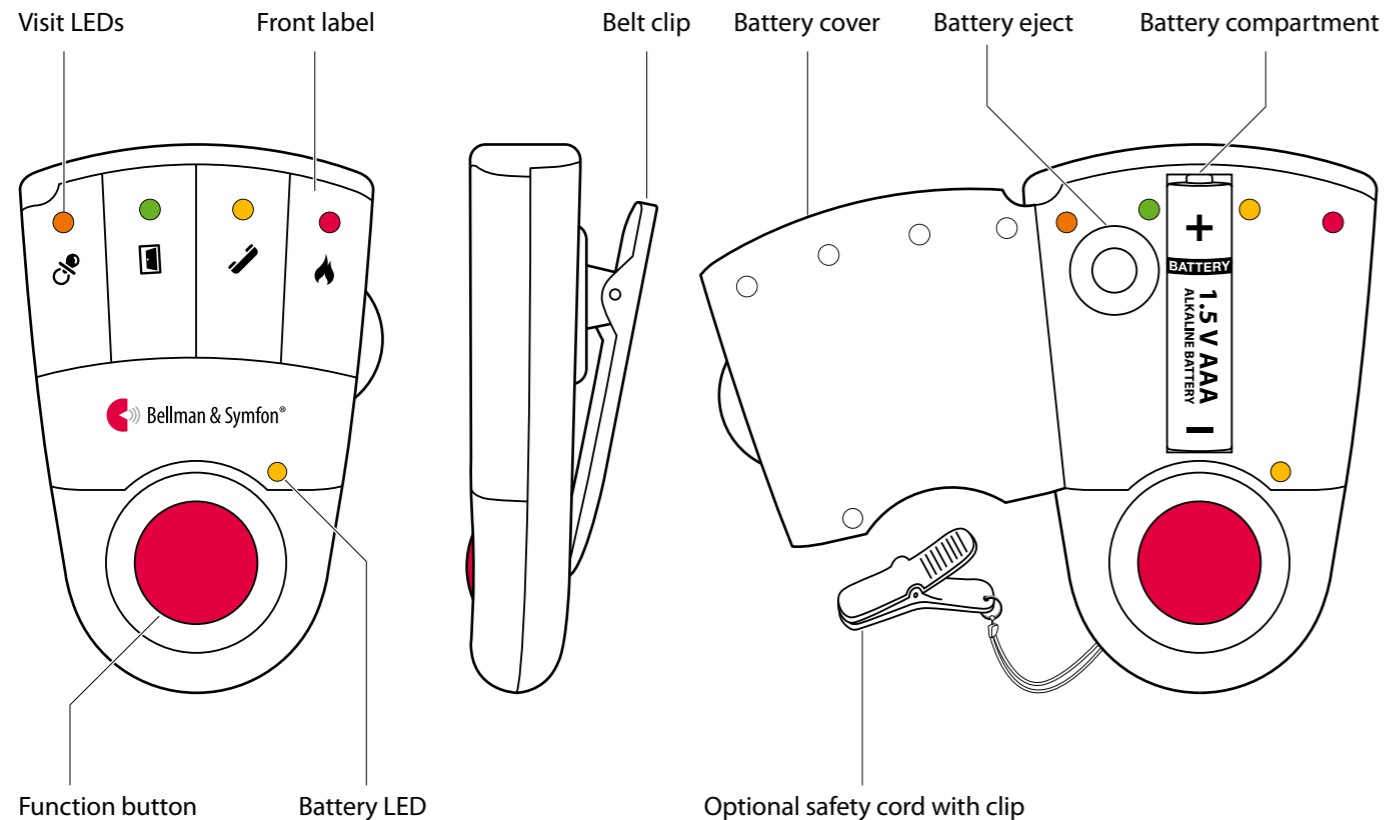

## Technical specifications

### In the box

- BE1470 Visit pager receiver
- Safety cord with clip
- Extra front label

### Power and battery

- Mains power  
7.5 V DC 200 mA via the charger
- Battery power  
1.5 V AAA alkaline or  
1.2 V AAA NiMH rechargeable battery
- Operation time  
Alkaline battery: 2 – 3 weeks  
NiMH battery: ~1 week
- Power consumption  
Active: ≤200 mA, Idle position: ≤1 mA

### Dimensions and weight

- Height: 86 mm, 3.4"
- Width: 57 mm, 2.2"
- Depth: 29 mm, 1.1"
- Weight: 70 g, 2.5 oz. incl. battery

### Visit LEDs

The Visit LEDs normally indicates the following:

- Orange LED, pacifier symbol  
The baby monitor is activated
- Green LED, door symbol  
The door transmitter is activated
- Yellow LED, telephone symbol  
The phone transmitter is activated
- Red LED, fire symbol  
The smoke alarm is activated

### Environment

- For indoor use only  
Operating temperature  
15° to 35° C, 59° to 95° F
- Relative humidity  
5% to 95%, non-condensing

### Frequency and coverage

- Radio frequency  
314.91 MHz, 433.92 MHz or 868.30 MHz, depending on the region
- Coverage  
50 – 250 m, 55 - 273 yd. depending on the radio frequency and the characteristics of the building

### Accessories

- BE1260 Pager charger
- BE1270 Bed shaker

## Getting started

- Open the battery cover, fit the battery and close the cover again. Attach the pager to your belt using the belt clip. For extra security, use the supplied safety cord.
- To test the radio link you need a Visit transmitter. Press the test button/s on the transmitter.
- The pager starts to vibrate and lights up a Visit LED. If a bed shaker is connected during charging, it will vibrate. If nothing happens, see **Troubleshooting**.

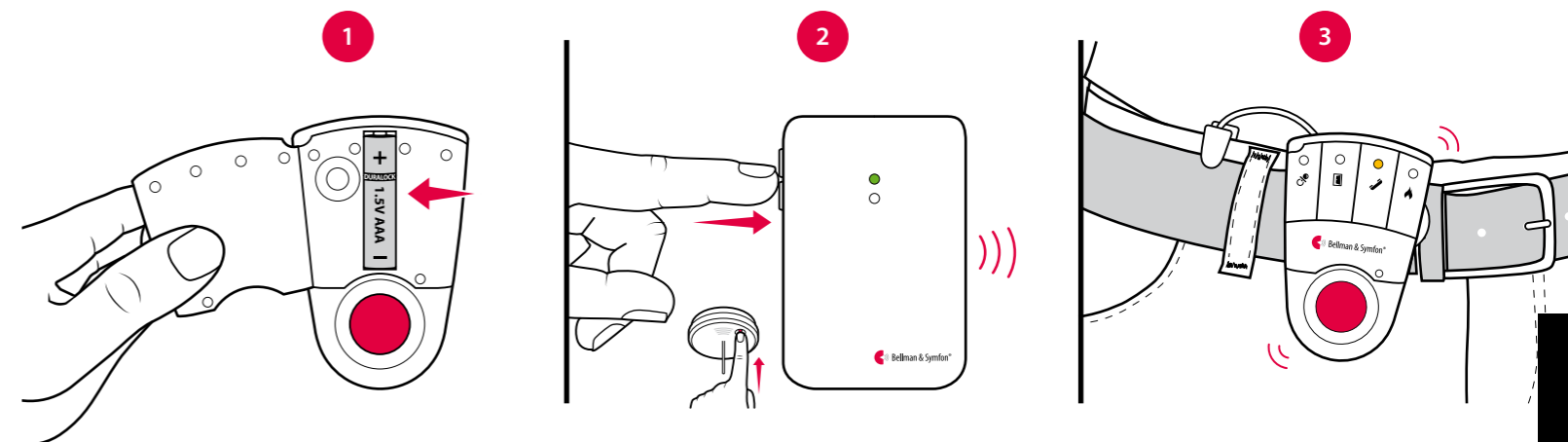

## Default signal pattern

When a transmitter is activated, the pager lights up an LED and starts to vibrate with a certain pace. This is called signal pattern. The transmitters determine the pattern, and the default is as follows:

### Activated transmitter

- Door transmitter
- Push button transmitter
- Telephone transmitter
- Baby monitor
- Smoke alarm

### Pager LED

- Green
- Green
- Yellow
- Orange
- Red

### Pager / bed shaker vibration

- Slow ■□□□
- Slow ■□□□
- Medium ■□■□
- Fast ■■■■■■
- Long ■■■■□

## Changing the signal pattern

The signal pattern can only be changed on the transmitters. See **Changing the signal pattern** for the relevant transmitter.

## Changing the front label

If you want to use Visit for other purposes, the pager front label can be replaced with a customized one. Here is how it's done:

- Open the battery cover, replace the original label with the supplied extra label and close the cover again.

## Replacing the battery

When the battery LED starts to blink in yellow, the battery is nearly depleted. Here is how you replace it:

- Open the battery cover and press the battery eject button to remove the old battery. Insert a 1.5 V AAA alkaline battery or a 1.2 V AAA NiMH rechargeable battery if you are using the BE1260 charger accessory.

# Visit pager receiver

## Changing the radio key

If your Visit system is activated for no reason, there is probably a nearby system that triggers yours. In order to avoid radio interference, you need to change the radio key on all units. The radio key switches are located on the **transmitters**.

### Here is how you change the radio key:

- 1 Open the transmitter cover and move any radio key switch to the up (on position) to change the radio key. See **Changing the radio key** for the relevant transmitter.
- 2 Press and hold the function button on the pager until the green and yellow Visit LEDs blink alternately. Release the button.
- 3 Press the test button/s on the transmitter within 30 seconds to send the new radio key.
- 4 All Visit LEDs on the pager blink 5 times to show that the radio key has been changed. It then returns to normal mode.

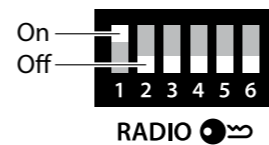

**Note:** All Visit units must be set to the same radio key in order to operate as a group.

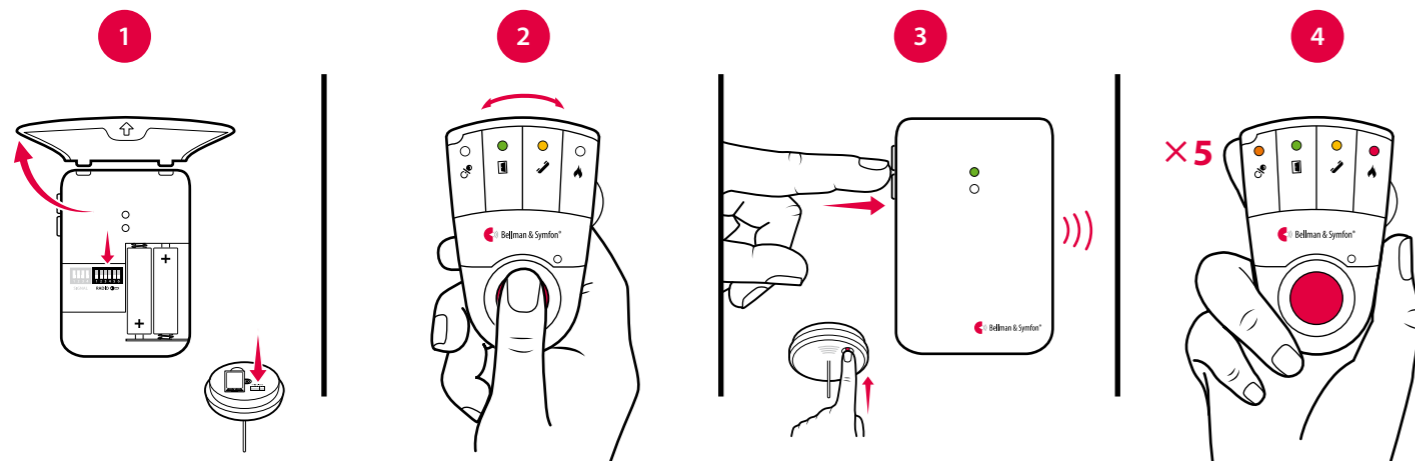

## Pager accessories

The pager can be complemented with the following accessories:

### BE1260 Pager charger

Charges your pager during the night. Place it on the bedside table and connect up to two bed shakers.

**Note:** The pager will not vibrate when it's charging, but the Visit LEDs will act as usual.

### BE1270 Bed shaker

Wakes you with vibrations if anything happens while you are asleep. Connect it to the pager charger and slide it under your pillow or mattress.

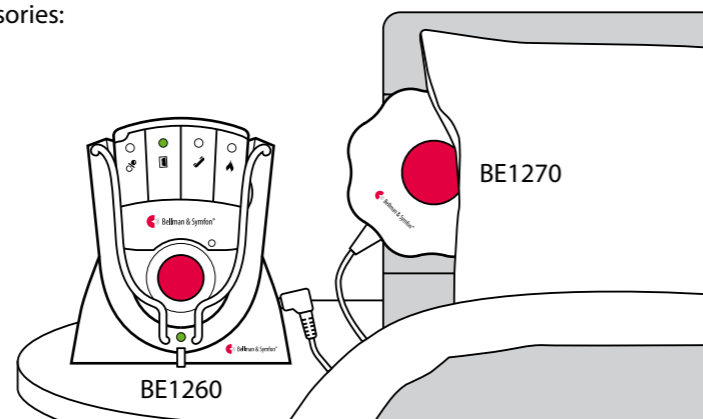

**Warning!** When using the pager charger **ONLY USE RECHARGEABLE NiMH BATTERIES** in the pager. Non-rechargeable batteries will start to leak if the pager is placed in the charger and the battery acid will damage the electronics. The resulting damage is not covered by warranty.

## Advanced programming

By using advanced programming, you can customize the signal pattern from a specific transmitter and event, displaying the LED colour and vibration pattern of your choice. The advanced programming overrides the radio key and pairs the units via the serial number. Please note that smoke alarms cannot be programmed for safety reasons.

**Note:** The transmitter must be activated as it is intended to be used in the system to generate the right signal. This means that you can't always use the transmitter test button (see **Default signal pattern** for the relevant transmitter).

### Here is how you program the pager:

- 1 Press and hold the function button on the pager. The green and yellow Visit LEDs will start to blink alternately. While still holding down the button, activate the desired transmitter as intended. The yellow battery LED on the pager will light up to indicate that you are in advanced programming mode. Release the button.
- 2 Scroll through the different **Visit LED options** by pressing the function button on the pager. Select the desired Visit LED pattern by holding down the function button until the battery LED goes out and lights up again.
- 3 Scroll through the different **vibration options** by pressing the function button on the pager. Select the desired vibration pattern by holding down the function button until the battery LED goes out and lights up again.
- 4 The pager will now show the new Visit LED colour and vibration pattern. Press the function button briefly to end the demonstration. After a short while, the pager will return to normal mode.

## Deleting the advanced programming

Follow the procedure below to delete the advanced programming.

- 1 Hold down the function button on the pager until the green and yellow Visit LEDs blink alternately. Release the button.
- 2 Press the function button on the pager 3 times in quick succession.
- 3 All Visit LEDs will light up for ~2 seconds to show that it has been deleted.

## Troubleshooting

Most problems with the pager can be solved quickly by following the advice below.

If	Try this
The pager seems to be turned off	<ul style="list-style-type: none"> <li>The battery is depleted. Replace it with a 1.5V AAA alkaline battery.</li> <li><b>Important!</b> If you have a pager charger; only use a rechargeable 1.2 V AAA NiMH battery in the pager.</li> </ul>
The battery LED blinks in yellow	<ul style="list-style-type: none"> <li>The battery level is low. Replace it with a 1.5V AAA alkaline battery.</li> <li><b>Important!</b> If you have a pager charger; only use a rechargeable 1.2 V AAA NiMH battery in the pager.</li> </ul>
The pager does not respond when a transmitter is activated	<ul style="list-style-type: none"> <li>Check the batteries in the transmitters.</li> <li>Move the pager closer to the transmitter to make sure it's within radio range.</li> <li>Check that the pager is set to the same radio key as the other units in the Visit system, see <b>Changing the radio key</b>.</li> </ul>
The pager is activated for no apparent reason	<ul style="list-style-type: none"> <li>There is probably another Visit system installed nearby that triggers your system. Change the radio key on all units, see <b>Changing the radio key</b>.</li> </ul>



# Visit wrist receiver

## Buttons and controls

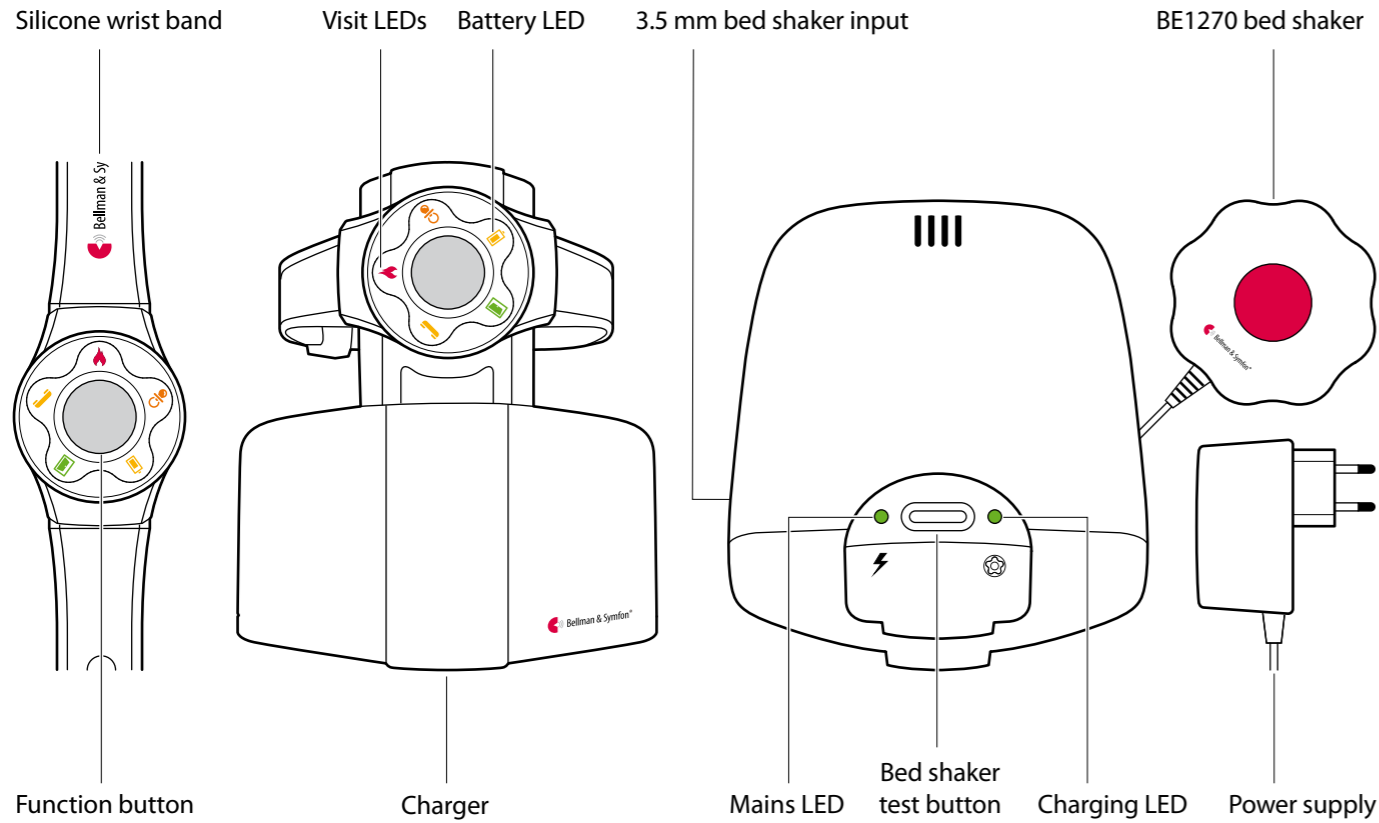

## Technical specifications

### In the box

- BE1560 Visit wrist receiver
- BE1570 Charger
- Elastic wrist band
- Power supply

### Dimensions and weight

	Receiver	Charger
Height	49 mm	100 mm
Width	38 mm	95 mm
Depth	12 mm	117 mm
Weight	27 g	185 g

### Environment

- For indoor use only
- Operating temperature: 15° to 35° C, 59° to 95° F
- Relative humidity: 5% to 95%, non-condensing

### Power and battery

- Mains power: 7.5V DC/1500 mA
- Power consumption  
Receiver: Active: 100 mA, Idle: 3 mA  
Charger: Active: 650 mA, Idle: 70 mA
- Battery power  
Receiver: 1 × 1.2 V V40H rechargeable  
Charger: 4 × 1.2 V NiMH rechargeable
- Operating and charging time  
Receiver: ~30 h, Charging time: ~8 h  
Charger: Battery charging time: ~24 h

### Visit LEDs

- The Visit LEDs normally indicates the following:
- Orange LED, pacifier symbol  
The baby monitor is activated
  - Green LED, door symbol  
The door transmitter is activated
  - Yellow LED, telephone symbol  
The phone transmitter is activated
  - Red LED, fire symbol  
The smoke alarm is activated

### Frequency and coverage

- Radio frequency: 314.91 MHz, 433.92 MHz or 868.30 MHz, depending on the region
- Coverage: 50 – 250 m, 55 - 273 yd. depending on the radio frequency and the characteristics of the building

### Accessories

- BE1270 Bed shaker
- BE9086 External trigger cable

## Getting started

- Pull the battery tab on the charger and connect the power supply to the mains outlet. The mains LED lights up in green. Place the wrist receiver in the charger and charge it for at least 2 hours. The charging LED is green during charging.
- To test the radio link you need a Visit transmitter. Press the test button/s on the transmitter.
- The receiver starts to vibrate and lights up a Visit LED. If a bed shaker is connected during charging, it will vibrate. If nothing happens, see **Troubleshooting**.

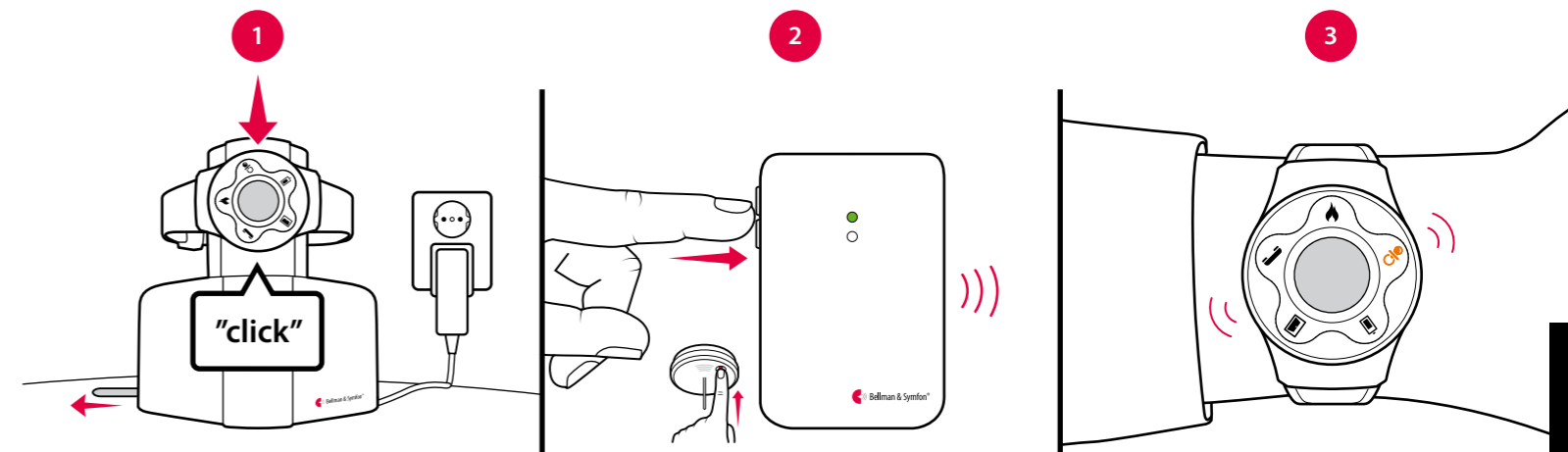

## Default signal pattern

When a transmitter is activated, the wrist receiver lights up an LED and starts to vibrate with a certain pace. This is called signal pattern. The transmitters determine the pattern, and the default is as follows:

### Activated transmitter

- Door transmitter
- Push button transmitter
- Telephone transmitter
- Baby monitor
- Smoke alarm

### Wrist receiver LED

- Green
- Green
- Yellow
- Orange
- Red

### Wrist receiver / bed shaker vibration

- Slow ■□□□
- Slow ■□□□
- Medium ■■□□
- Fast ■■■■■■
- Long ■■■■□

## Changing the signal pattern

The signal pattern can only be changed on the transmitters. See **Changing the signal pattern** for the relevant transmitter.

## LED indications

When the wrist receiver battery is nearly depleted, the battery LED starts to blink in yellow. The charging time is up to 8 h. The charger is equipped with a battery backup and the charger LEDs indicate the following:

### LED

- Charging LED
- Mains LED
- Mains LED

### Indication

- Green light
- Green light
- Green blinks

### Status

- The receiver battery is being charged.
- The charger is powered by mains voltage.
- The charger is powered by the battery backup.

# Visit wrist receiver

## Changing the radio key

If your Visit system is activated for no reason, there is probably a nearby system that triggers yours. In order to avoid radio interference, you need to change the radio key on all units. The radio key switches are located on the **transmitters**.

### Here is how you change the radio key:

- 1 Open the transmitter cover and move any radio key switch to the up (on position) to change the radio key. See **Changing the radio key** for the relevant transmitter.
- 2 Press and hold the function button on the wrist receiver until the green and yellow Visit LEDs blink alternately. Release the button.
- 3 Press the test button/s on the transmitter within 30 seconds to send the new radio key.
- 4 All Visit LEDs on the receiver blink 5 times to show that the radio key has been changed. It then returns to normal mode.

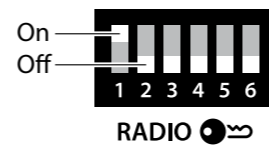

**Note:** All Visit units must be set to the same radio key in order to operate as a group.

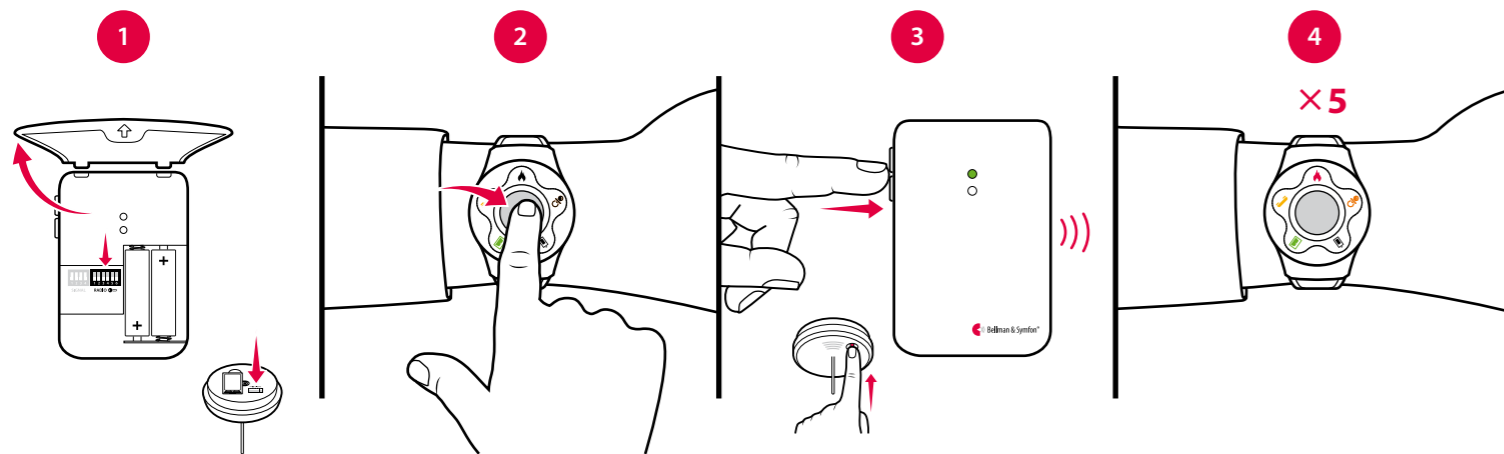

## Accessories

The wrist receiver can be complemented with the following accessory:

### BE1270 Bed shaker

Wakes you with vibrations if anything happens while you are asleep. Connect it to the charger and slide it under your pillow or mattress.

**Note:** The bed shaker only works when the wrist receiver is placed in the charger. The receiver will not vibrate during charging, but the Visit LEDs will act as usual.

Press the bed shaker test button on top of the charger to try the bed shaker vibration.

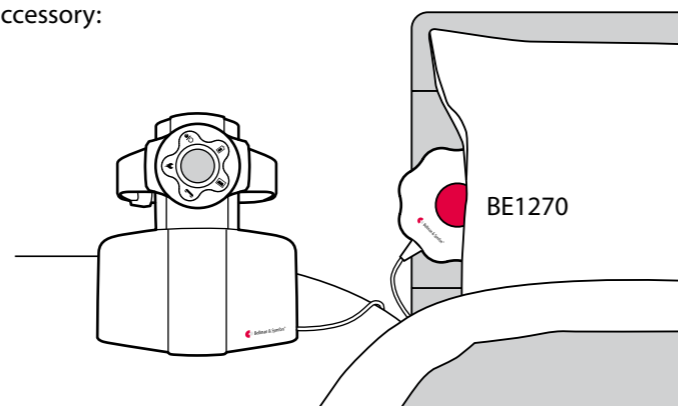

**Warning!** The wrist receiver and charger can **ONLY USE RECHARGEABLE NiMH BATTERIES**. Non-rechargeable batteries will start to leak during charging and the battery acid will damage the electronics in the wrist receiver and charger. The resulting damage is not covered by warranty.

## Advanced programming

By using advanced programming, you can customize the signal pattern from a specific transmitter and event, displaying the LED colour and vibration pattern of your choice. The advanced programming overrides the radio key and pairs the units via the serial number. Please note that smoke alarms cannot be programmed for safety reasons.

**Note:** The transmitter must be activated as it is intended to be used in the system to generate the right signal. This means that you can't always use the transmitter test button (see **Default signal pattern** for the relevant transmitter).

### Here is how you program the wrist receiver:

- 1 Press and hold the function button on the receiver. The green and yellow Visit LEDs will start to blink alternately. While still holding down the button, activate the desired transmitter as intended. The battery LED on the receiver lights up in yellow to show that you are in advanced programming mode. Release the button.
- 2 Scroll through the different **Visit LED options** by pressing the function button on the receiver. Select the desired Visit LED colour by holding down the function button until the battery LED goes out and lights up again.
- 3 Scroll through the different **vibration options** by pressing the function button on the receiver. Select the desired vibration pattern by holding down the function button until the battery LED goes out and lights up again.
- 4 The wrist receiver will now show the new Visit LED colour and vibration pattern. Press the function button briefly to end the demonstration. After a short while, it will return to normal mode.

## Deleting the advanced programming

Follow the procedure below to delete the advanced programming.

- 1 Hold down the function button on the receiver until the green and yellow Visit LEDs blink alternately. Release the button.
- 2 Press the function button on the receiver 3 times in quick succession.
- 3 All Visit LEDs will light up for ~2 seconds to show that it has been deleted.

## Troubleshooting

Most problems with the wrist receiver can be solved quickly by following the advice below.

If	Try this
The receiver seems to be turned off	<ul style="list-style-type: none"> <li>The battery is depleted. Charge or replace it with a VARTA V40H NiMH battery.</li> </ul>
The battery LED blinks in yellow	<ul style="list-style-type: none"> <li>The battery level is low. Charge or replace it with a VARTA V40H NiMH battery.</li> </ul>
The receiver is not charging	<ul style="list-style-type: none"> <li>Check that the receiver is placed correctly in the charger and that the power supply is connected. The mains LED and charging LED should be lit.</li> <li>Charge or replace the backup batteries with four 1.2 V NiMH rechargeable batteries.</li> </ul>
The receiver does not respond when a transmitter is activated	<ul style="list-style-type: none"> <li>Check the transmitter batteries and connections.</li> <li>Move the receiver closer to the transmitter to make sure it's within radio range.</li> <li>Check that the receiver is set to the same radio key as the other units in the Visit system, see <b>Changing the radio key</b>.</li> </ul>
The receiver is activated for no apparent reason	<ul style="list-style-type: none"> <li>There is probably another Visit system installed nearby that triggers your system. Change the radio key on all units, see <b>Changing the radio key</b>.</li> </ul>
The bed shaker does not vibrate	<ul style="list-style-type: none"> <li>Check that the bed shaker is connected and that the receiver is placed in the charger.</li> </ul>



# Visit alarm clock receiver

## Buttons and controls

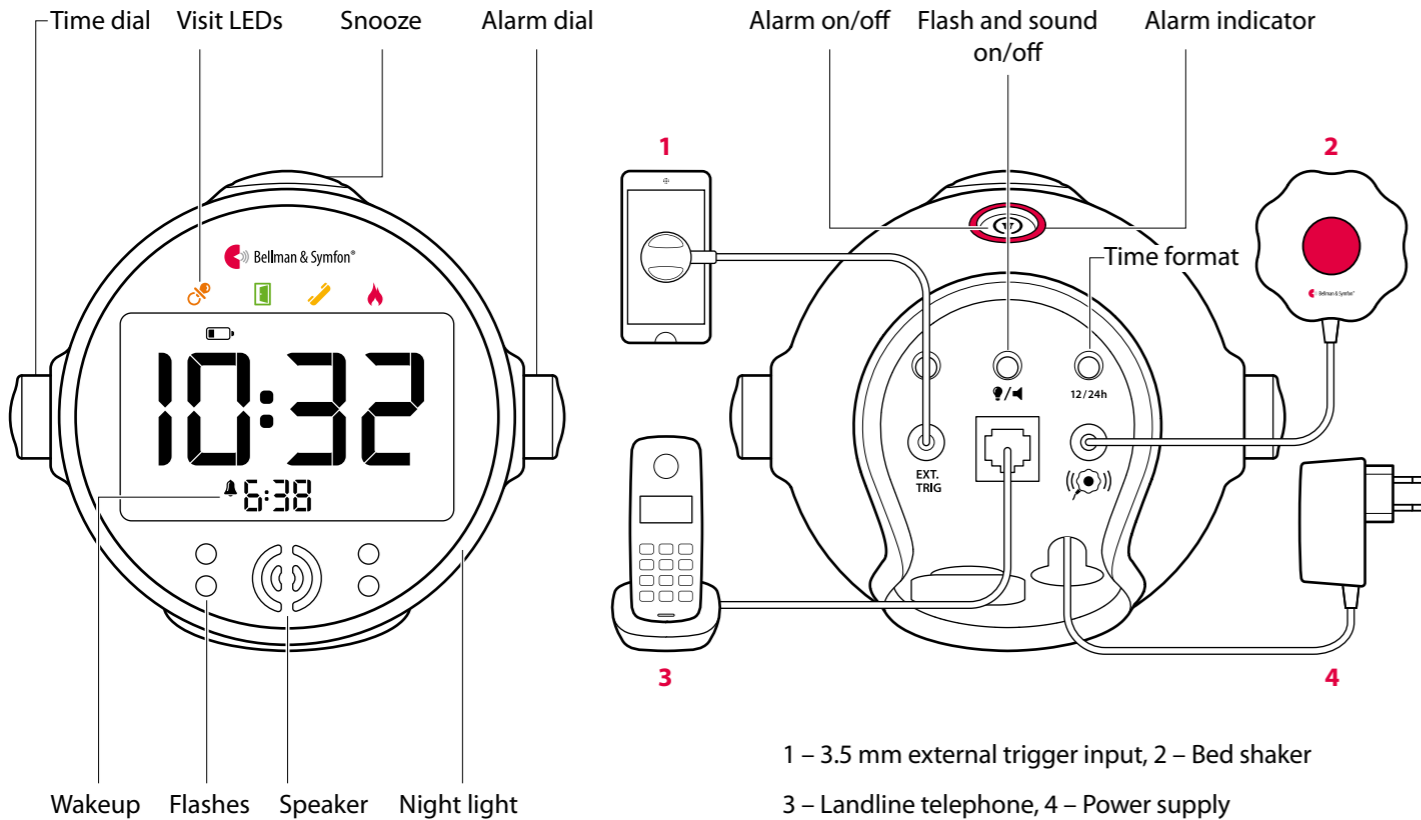

## Technical specifications

### In the box

- BE1580 Visit alarm clock
- BE1272 Bed shaker with sound
- Power supply
- 4 × 1.2 V AAA NiMH batteries

### Dimensions and weight

- Height: 108 mm, 4.3"
- Width: 121 mm, 4.7"
- Depth: 92 mm, 3.6"
- Weight: 390 g, 13.7 oz. incl. batteries

### Output signals

- Sound  
100 dB @ 10 cm, 950 Hz – 3 kHz
- Four high-intensity flashing LEDs
- Bed shaker power: 2.0 – 4.0 VDC  
The bed shaker emits a sound

### Power and battery

- Mains power  
7.5 V DC / 1000 mA  
External power supply unit
- Backup batteries  
4 × 1.2 V AAA NiMH rechargeable batteries
- Battery backup operating time  
~ 24 h when fully charged
- Battery backup charging time  
~ 10 h from fully depleted

### Visit LEDs

- The Visit LEDs normally indicates the following:
- Orange LED, pacifier symbol  
The baby monitor is activated
  - Green LED, door symbol  
The door transmitter is activated
  - Yellow LED, telephone symbol  
The phone transmitter is activated
  - Red LED, fire symbol  
The smoke alarm is activated

### Frequency and coverage

- Radio frequency  
314.91 MHz, 433.92 MHz or 868.30 MHz, depending on the region
- Coverage  
50 – 250 m, 55 - 273 yd. depending on the radio frequency and the characteristics of the building

### Accessories

- BE9250 Mobile phone sensor

## Getting started

- Pull the battery tab and connect the power supply to the alarm clock and the mains outlet. Connect the bed shaker, tuck it under the pillow or mattress, and place the alarm clock on the bedside table.
- To test the radio link you need a Visit transmitter. Press the test button/s on the transmitter.
- The alarm clock lights up a Visit LED and starts to sound and flash. The bed shaker emits a sound and vibrates. If nothing happens, see **Troubleshooting**.

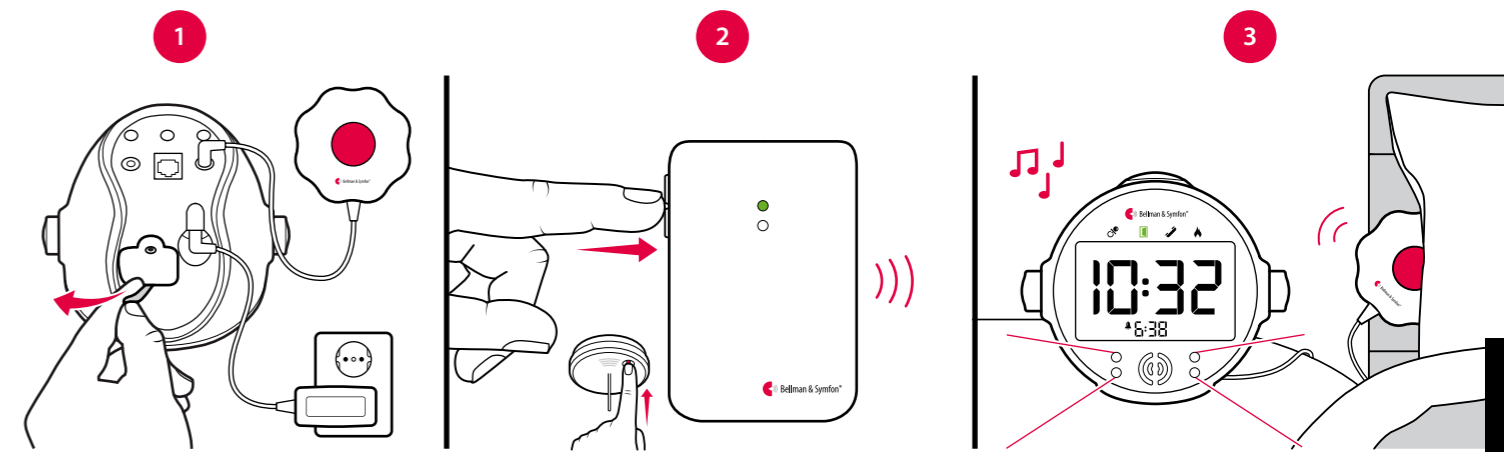

## Default signal pattern

When a transmitter is activated, the alarm clock lights up an LED, sounds, flashes and the bed shaker starts to vibrate with a certain pace. This is called signal pattern. The transmitters determine the pattern, and the default is as follows:

Transmitter	Alarm clock			Bed shaker
Activated source	Visit LED	Sound	Flash	Vibration
Door transmitter / push button transmitter	Green	Door chime	Yes	Slow ■■■■
Telephone transmitter / connected telephone	Yellow	Ring signal	Yes	Medium ■■■■
Baby monitor	Orange	Baby melody	Yes	Fast ■■■■■■
Smoke alarm	Red	Fire horn	Yes	Long ■■■■

## Changing the signal pattern

The signal pattern can only be changed on the transmitters. See **Changing the signal pattern** for the relevant transmitter.

## Settings

### Flash and sound on/off

Press the flash and sound on/off button marked with on the back of the alarm clock repeatedly to toggle between the options. A icon will appear on the clock face when the flash is turned off and a icon when the sound is muted.

### Display backlight

Press the button marked with repeatedly to adjust the intensity in 4 steps. **Step 5 results in permanent backlight.**

### Time format

Press the time format button marked with **12/24h** on the back of the alarm clock to toggle between a 24h and a 12h setting.



# Visit alarm clock receiver

## Setting the time

Press the **left** dial and turn it to set hours.  
To set minutes, press and turn the dial again.  
Press once again to save your settings.

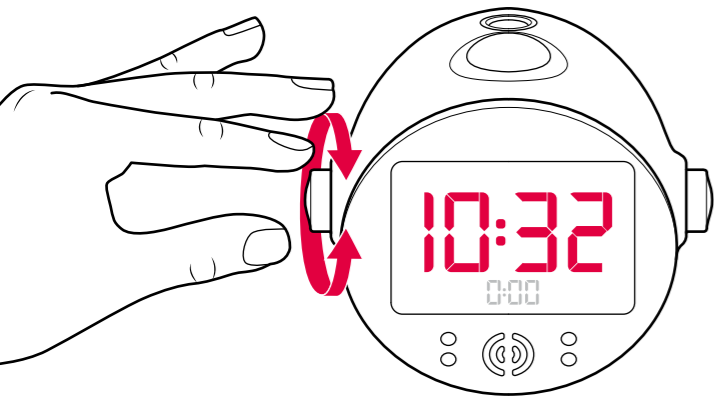

## Setting the alarm

Press the **right** dial and turn it to set hours.  
To set minutes, press and turn the dial again.  
Press once again to save your settings.

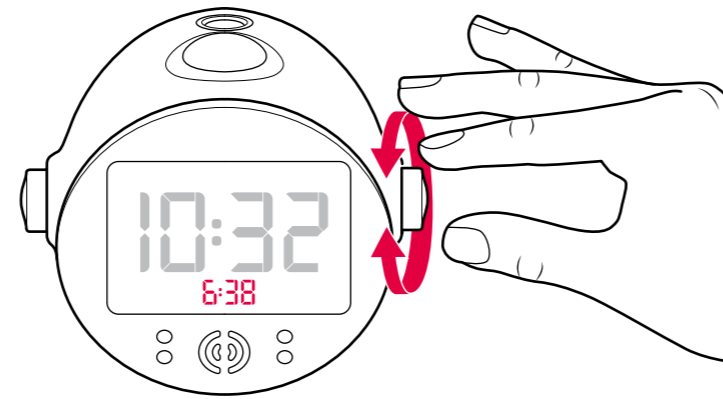

## Activating the alarm

Press the alarm on/off button to activate the alarm.  
The alarm indicator lights up in red. To turn off the alarm, press the button again.

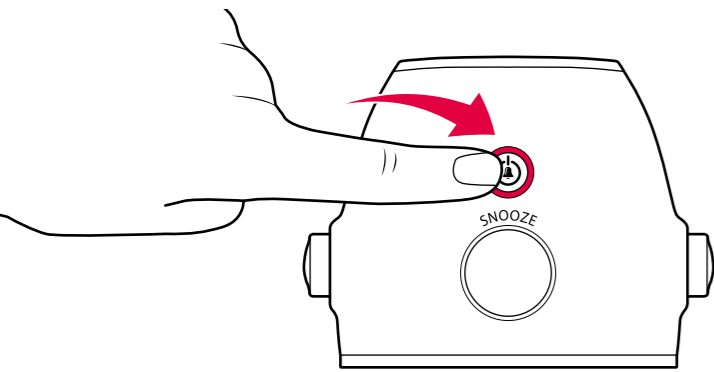

## Using the snooze and night light

Press the snooze button briefly to snooze the alarm (fire alarms cannot be snoozed for security reasons).  
Press and hold the snooze button for 3 seconds to turn on the night light. Press the button again to turn it off.

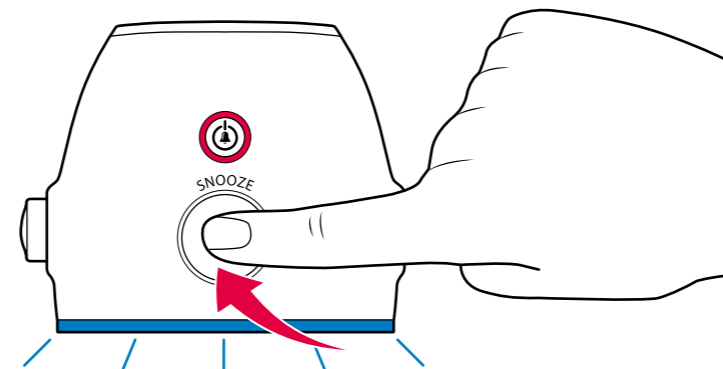

## Alarm clock accessories

The alarm clock can be complemented with the following accessories:

- **BE9105 Telephone cord**  
Use it to connect the landline telephone to the alarm clock RJ11 input and be alerted when the telephone rings.
- **BE9250 Mobile phone sensor**  
Connect it to the ext. trig. input and place it on the display to be alerted by incoming calls or messages.
- **BE9026 Contact mat**  
Connect it to the ext. trig. input to be alerted when your partner leaves the bed.

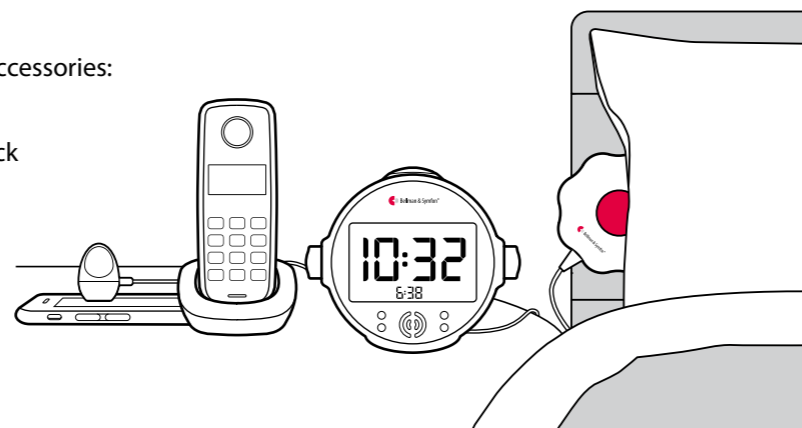

## Changing the radio key

If your Visit system is activated for no reason, there is probably a nearby system that triggers yours. In order to avoid radio interference, you need to change the radio key on all units. The radio key switches are located on the **transmitters**.

**Here is how you change the radio key:**



- 1 Open the transmitter cover and move any radio key switch to the up (on) position to change the radio key. See **Changing the radio key** for the relevant transmitter.
- 2 Press and hold the snooze button on the alarm clock until the green and yellow Visit LEDs blink alternately. Release the button.
- 3 Press the test button/s on the transmitter within 30 seconds to send the new radio key.
- 4 All Visit LEDs on the alarm clock blink 5 times to show that the radio key has been changed. It then returns to normal mode.

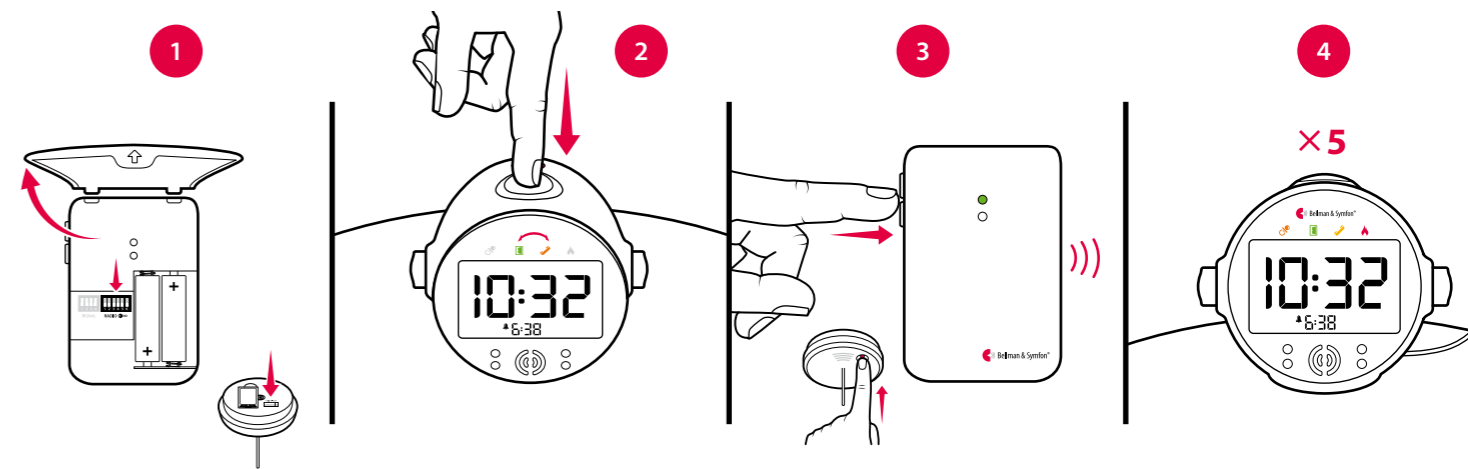

**Note:** All Visit units must be set to the same radio key in order to operate as a group.



## Troubleshooting

If	Try this
The alarm clock seems to be turned off	<ul style="list-style-type: none"> <li>▪ Check that the power supply is connected correctly.</li> <li>▪ Charge the backup batteries for a couple of hours.</li> </ul>
The  symbol on the clock face starts to blink	<ul style="list-style-type: none"> <li>▪ The power supply is disconnected and the backup batteries are nearly depleted. Connect the power supply and charge the backup batteries for a couple of hours.</li> </ul>
A  symbol appears on the clock face	<ul style="list-style-type: none"> <li>▪ The receiver detects no backup batteries. Pull the battery tab, see <b>Getting started</b>.</li> </ul>
The alarm clock does not respond when a transmitter is activated	<ul style="list-style-type: none"> <li>▪ Check the transmitter batteries and connections.</li> <li>▪ Move the alarm clock closer to the transmitter to make sure it's within radio range.</li> <li>▪ Check that the alarm clock is set to the same radio key as the other units in the Visit system, see <b>Changing the radio key</b>.</li> </ul>
The alarm clock is activated for no apparent reason	<ul style="list-style-type: none"> <li>▪ There is probably another Visit system installed nearby that triggers your system. Change the radio key on all units, see <b>Changing the radio key</b>.</li> </ul>
The alarm volume is too low	<ul style="list-style-type: none"> <li>▪ The volume increases gradually and reaches over 100 dB.</li> </ul>





BE1260

# Pager charger

## Buttons and controls

Charger brackets

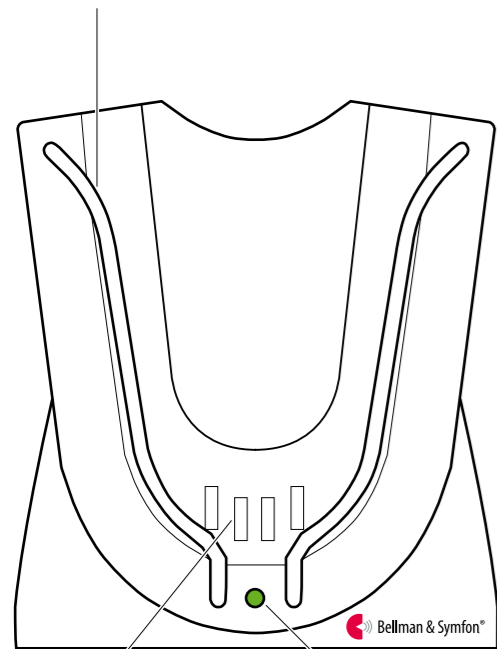

Charging pins

Charging LED

BE1270 bed shaker

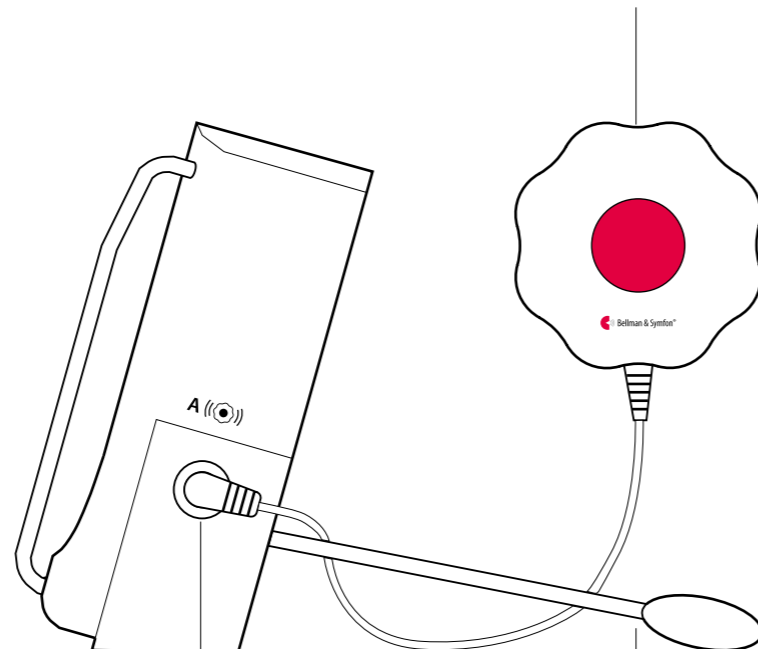

2x bed shaker jacks

Supporting legs

## Technical specifications

### In the box

- BE1260 Pager charger with pre-mounted backup batteries
- External power supply
- 1 × 1.2 V NiMH rechargeable battery intended for the pager
- Supporting legs and screws + plugs

### Charging LED

- Green light:** The pager is charging
- No light:** The pager is fully charged or the power supply is not connected to mains power.

### Power and battery

- Mains power: 8 VDC / 800 mA
- Battery power  
4 × 1.2 V NiMH rechargeable batteries

**Note:** The backup batteries must be changed at a service center.

- Pager charging time  
Normal charging time: ~ 6 h  
W. depleted backup batteries: ~ 24 h

- Vibrator power: 2.0 – 4.0 VDC

### Environment

- For indoor use only

### Dimensions and weight

- Height: 78 mm, 3"
- Width: 88 mm, 3.5"
- Depth: 43 mm, 1.7"
- Weight: 385 g, 16.3 oz. incl. batteries

### Accessories

- BE1270 Bed shaker  
Connects up to two bed shakers
- BE9086 External trigger cable  
Use output B

## Getting started

- Important!** Replace the old alkaline battery with the supplied 1.2 V NiMH rechargeable battery.
- Fit the supporting legs to the back of the charger and place it on a level surface. You can also mount it on the wall using the supplied screws and plugs.
- Connect the power supply to the mains outlet and place the pager in the charger. The charging LED is green during charging and goes out when the pager is fully charged. Connect the bed shaker and tuck it under the pillow or mattress.

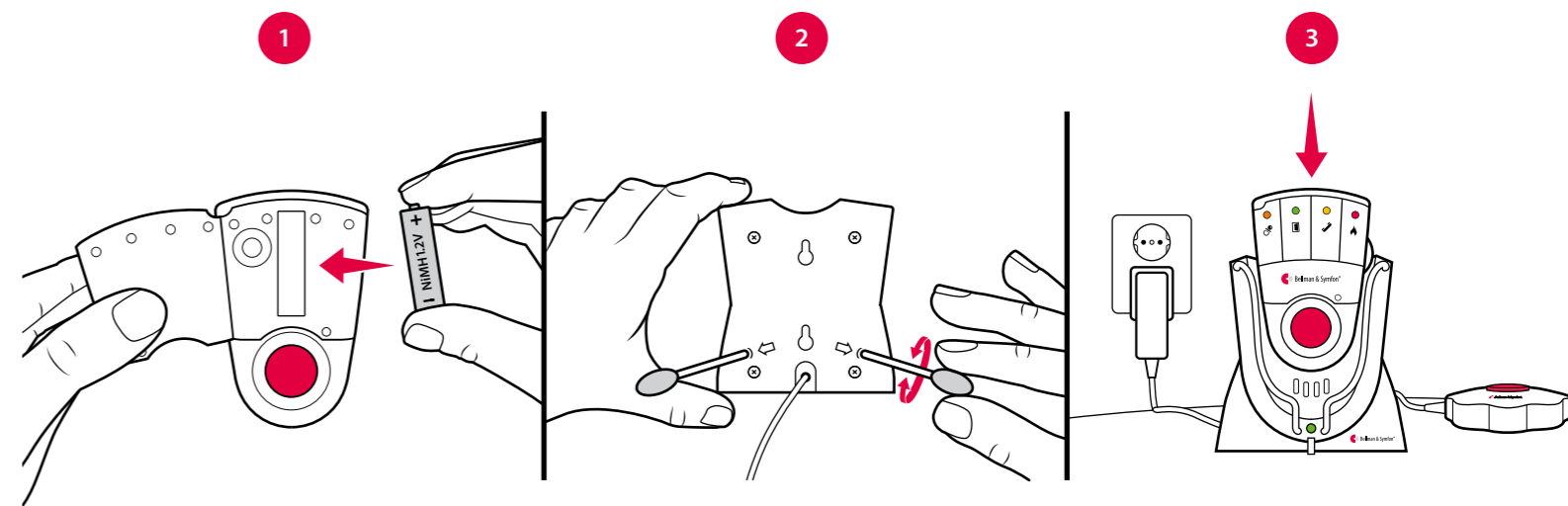

## Testing the connection

**Note:** Charge the backup batteries for 24 hours before using it with a bed shaker.

- To test the radio link you need the pager and a Visit transmitter. Press the test button/s on the transmitter (see **Testing the connection** for the relevant transmitter).
- If the pager is placed in the charger, it lights up a Visit LED and the bed shaker starts to vibrate. If nothing happens, see **Troubleshooting**.

## Troubleshooting

Most problems with the charger can be solved quickly by following the advice below.

### If

The pager doesn't charge when it's placed in the charger

### Try this

- Check that the pager is positioned correctly in the charger. The charging LED will light up in green to show that the pager is being charged.
- If the charging LED doesn't light up, the backup batteries may be depleted. Connect the power supply to mains power and charge the backup batteries.

The bed shaker doesn't vibrate when the the pager is activated

- Check that the bed shaker is connected correctly to the charger.
- Check that the pager is positioned correctly in the charger. The charging LED will light up in green to show that the pager is being charged.
- If the charging LED doesn't light up, the backup batteries may be depleted. Connect the power supply to mains power and charge the backup batteries.



**Warning!** When using the pager charger **ONLY USE RECHARGEABLE NiMH BATTERIES** in the pager. Non-rechargeable batteries will start to leak if the pager is placed in the charger and the battery acid will damage the electronics. The resulting damage is not covered by warranty.

# Mobile phone sensor



BE9250 | BE9251

## Buttons and connections

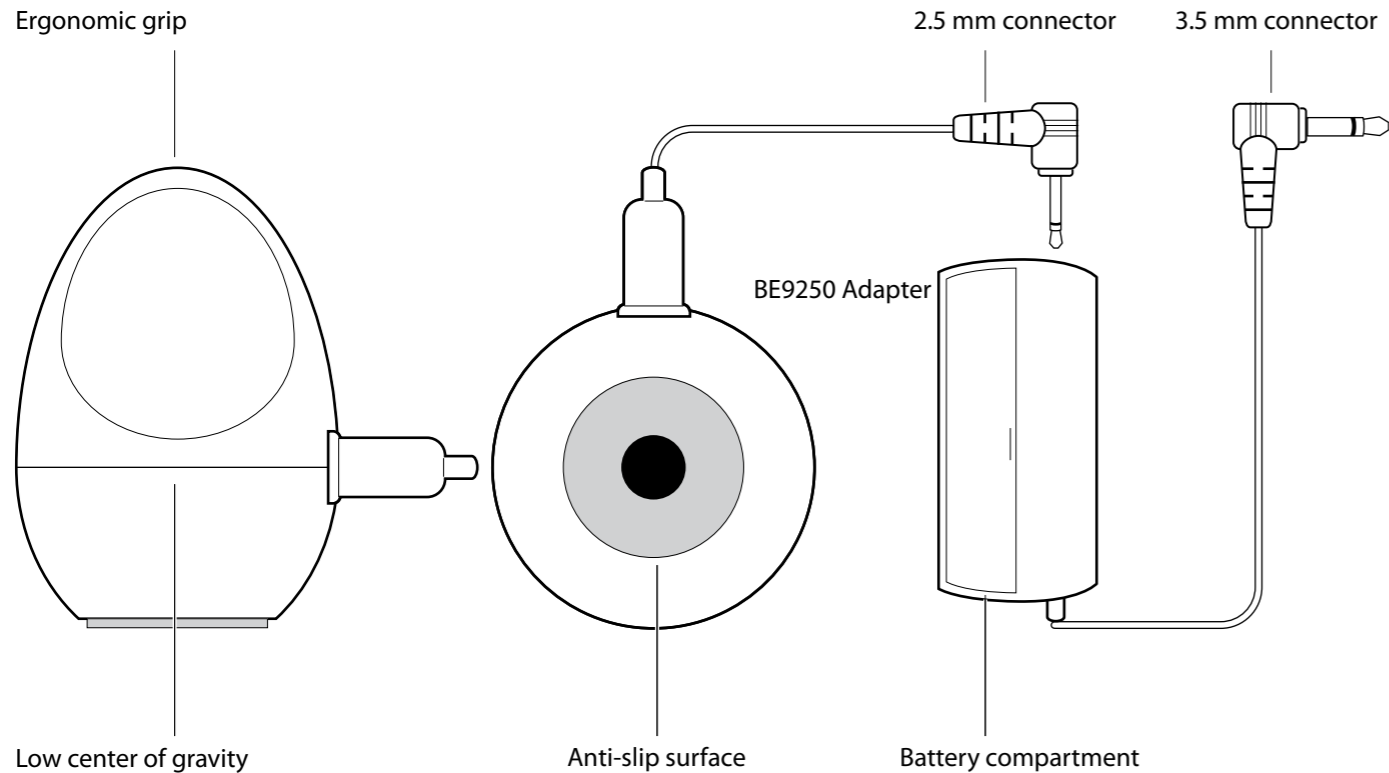

## Model overview

### BE9250 model

The BE9250 model has an adapter and connects to all Bellman & Symfon products with a 3.5 mm ext. trig. input.

### Compatibility

- BE1580 Visit alarm clock
- BE1370 Pro alarm clock

### Technical specifications

- Battery power: 1 × AAA 1.5 V alkaline battery
- Optical detection: Activated when the display lights up
- Light sensitivity: Visible light >3 lux for longer than 2 s
- Connectors:  
Mobile phone sensor: 2.5 mm mono jack plug  
Adapter: 3.5 mm mono jack plug
- Cable length: 120 cm, 4'
- Sensor dimensions and weight: 24 × 34 × 24 mm, 20 g  
Adapter dimensions and weight: 53 × 25 × 18 mm, 27 g

### BE9251 model

The BE9251 model connects to all Bellman & Symfon products that features a 2.5 mm ext. trig. input.

### Compatibility

- BE1431 Telephone transmitter
- BE1441 Visit flash receiver
- BE1442 Visit flash receiver with battery backup
- BE1444 Visit flash receiver with battery backup and advanced smoke detector supervision

### Technical specifications

- Placement: Horizontally on the display
- Optical detection: Activated when the display lights up
- Light sensitivity: Visible light >3 lux for longer than 2 s
- Connector: 2.5 mm mono jack plug
- Cable length: 120 cm, 4'
- Sensor dimensions and weight: 24 × 34 × 24 mm, 20 g

## Using BE9250 with the alarm clock

- 1 Open the battery compartment, fit the supplied battery and connect the mobile phone sensor to the 2.5 mm input.
- 2 Connect the adapter to the 3.5 mm ext. trig. input on the back of the alarm clock.
- 3 Place the sensor on the mobile phone or tablet display and use e.g. a landline telephone to call the mobile phone. When the display lights up, the yellow Visit LED on the alarm clock blinks and it starts to sound, flash and vibrate.

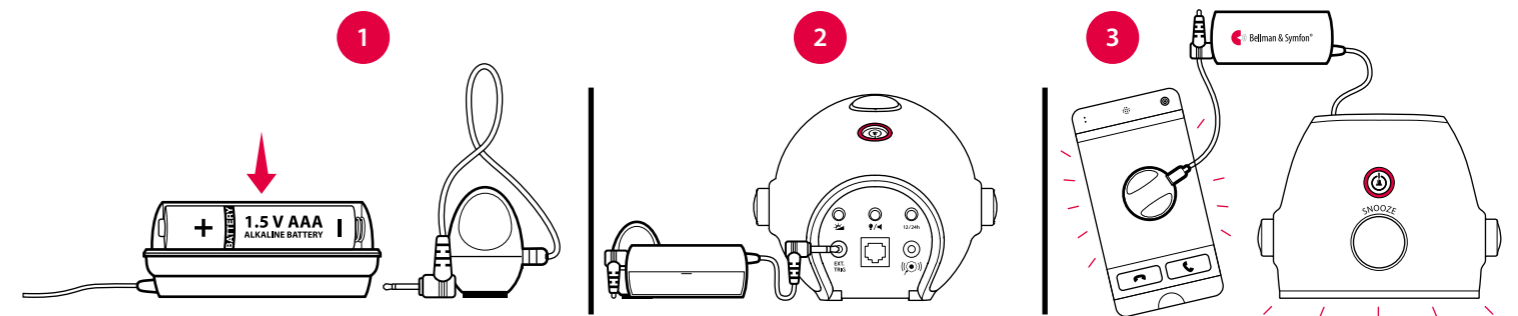

## Using BE9251 with the flash receiver

- 1 Connect the mobile phone sensor to the 2.5 mm ext. trig. input on the back of the receiver. Place it on the mobile phone or tablet display.
- 2 Use for instance the landline telephone to call the mobile phone. When the mobile phone display lights up, the yellow Visit LED on the receiver lights up and it starts to flash.



## Using BE9251 with the telephone transmitter

- 1 Open the telephone transmitter front cover and connect the mobile phone sensor to the 2.5 mm ext. trig. input. Place it on the mobile phone or tablet display.
- 2 Use for instance the landline telephone to call the mobile phone. When the mobile phone display lights up, the transmitter top LED lights up in green to show that a radio signal is being transmitted.
- 3 The yellow Visit LED on the receiver lights up to show that the signal was received. In addition, it starts to sound, flash or vibrate depending on the receiver.

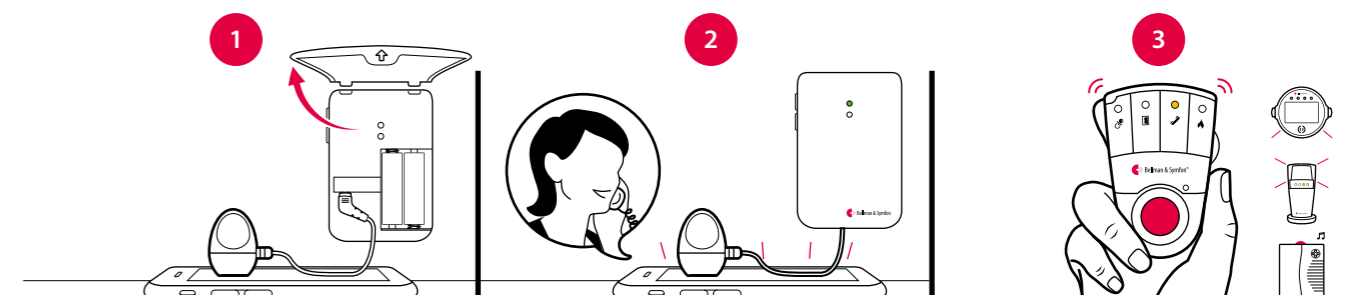

# Bed shaker



BE1270

## Connections

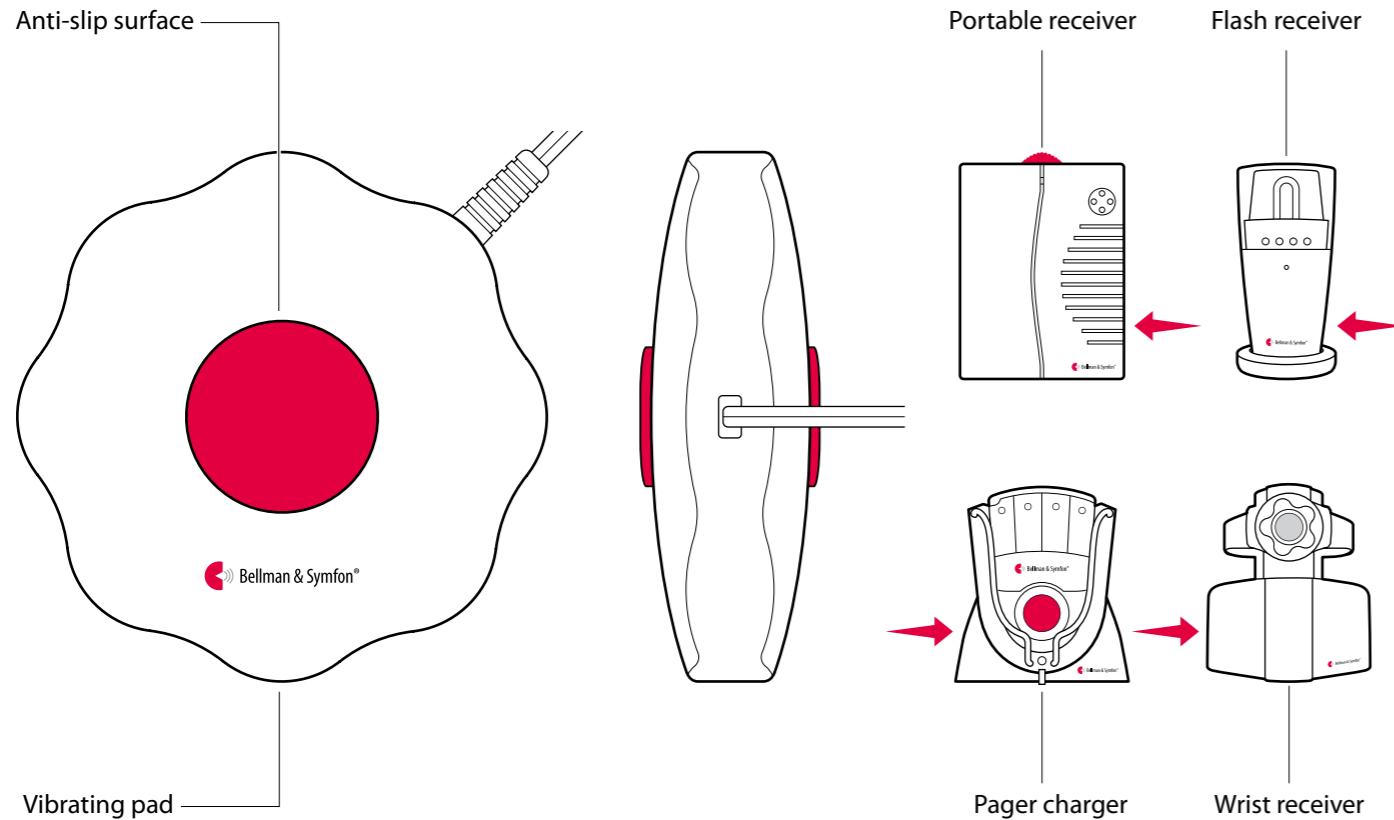

## Technical specifications

### Function

Wakes you with vibrations under the pillow or mattress. Requires no internal battery and connects to all Visit receivers and charger accessories.

### In the box

- BE1270 bed shaker

### Power consumption

- Operating voltage: 2.0 – 4.0 V DC from a Visit receiver
- Power consumption: 250 – 750 mA

### Cables and connectors

- Cable length: 2 m, 6.5'
- Connector: 3.5 mm mono jack plug

### Dimensions and weight

- Height: 88 mm, 3.5"
- Width: 88 mm, 3.5"
- Depth: 27 mm, 1.1"
- Weight: 120 g, 4.2 oz.

### Environmental requirements

- For indoor use only
- Temperature: 59° to 95° F, 15°-35° C
- Relative humidity: 5% -95% Non-condensing

### Maintenance and care

- Clean with a dry cloth
- Do not use household cleaners, aerosol sprays, solvents, alcohol, ammonia, or abrasives

### Compatibility

The bed shaker can be connected to the following Visit receivers and charger accessories:

### Visit receivers

- BE1450 Visit portable receiver
- BE1441 Visit flash receiver
- BE1442 Visit flash receiver with battery backup
- BE1444 Visit flash receiver with battery backup and advanced smoke detector supervision
- BE1570 Visit wrist receiver charger

### Accessories

- BE1260 Pager charger accessory for the BE1470 Visit pager receiver

# Flash receiver wall bracket



BE9075

## Using a flash receiver

### BE1441

- 1 Use the drilling template to mark and drill holes for the screws and plugs.
- 2 Remove the flash receiver table stand using the Allen key.
- 3 Fit the wall bracket on the wall. Attach the bottom and mount the flash receiver on the wall bracket.

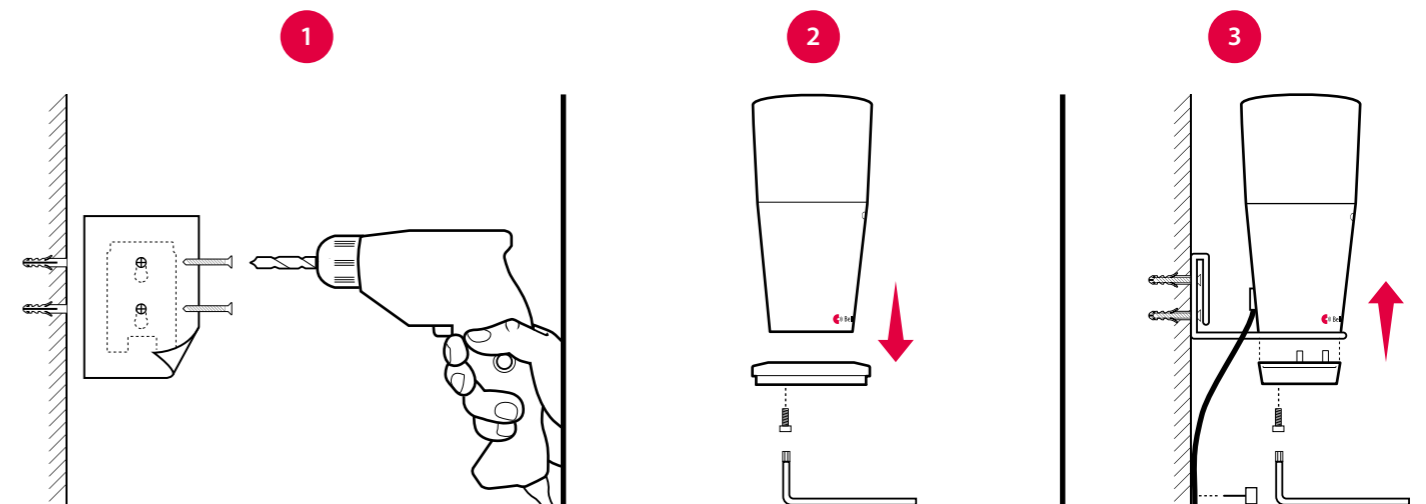

## Using a flash receiver with battery backup

### BE1442/BE1444

- 1 Use the drilling template to mark and drill holes for the screws and plugs.
- 2 Remove the screw marked in red, located at the bottom of the flash receiver.
- 3 Fit the wall bracket on the wall. Re-attach the screw to mount the flash receiver on the wall bracket.

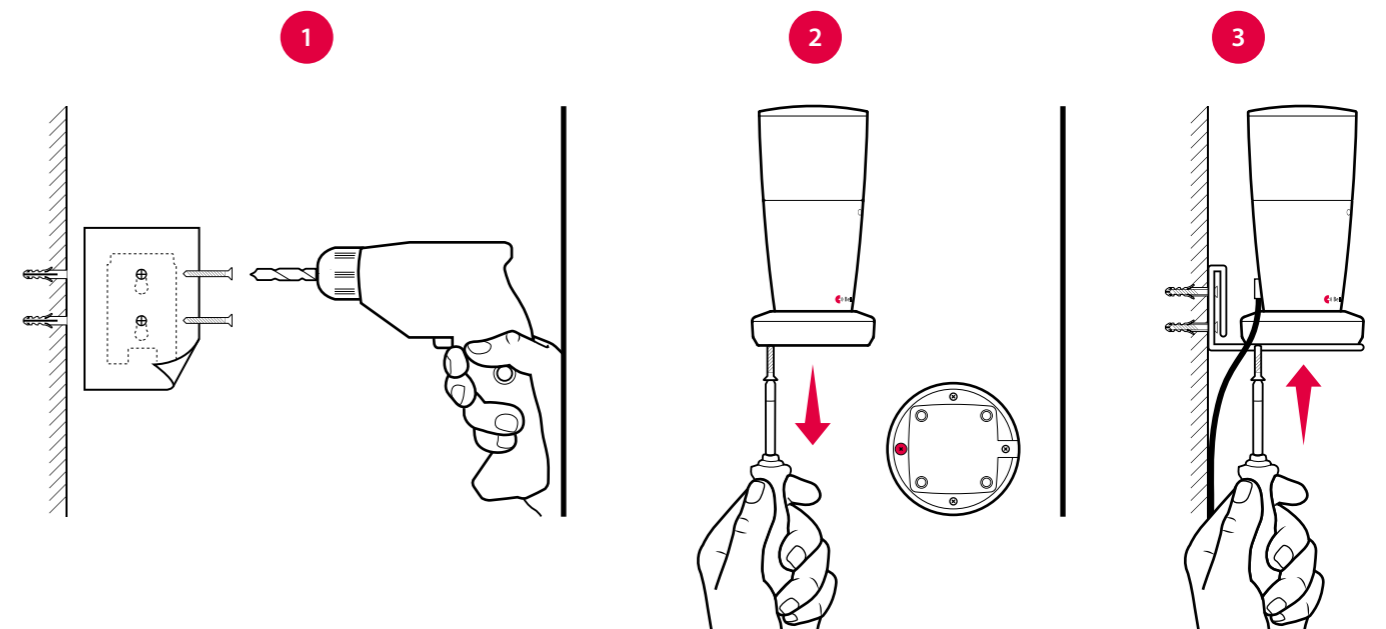

# Visit accessories

## Magnetic switch

### Monitors the door and window

Mount the magnetic switch on the door or window frame and connect it to the telephone transmitter. When the magnets are separated, the transmitter signals the Visit receiver.

### Technical specifications

- Dimensions 25×62×13 mm, 1"×2.5"×0.5"
- Weight 25 g, 0.9 oz.
- Connector 3.5 mm mono jack plug
- Cable length 0.5 m, 1.6'
- Contact breaker  
Switch ON (door opened) > 2 cm, 0.8" from the magnet  
Switch OFF (door closed) < 1 cm, 0.4" from the magnet
- Colour White
- Environment For indoor use only

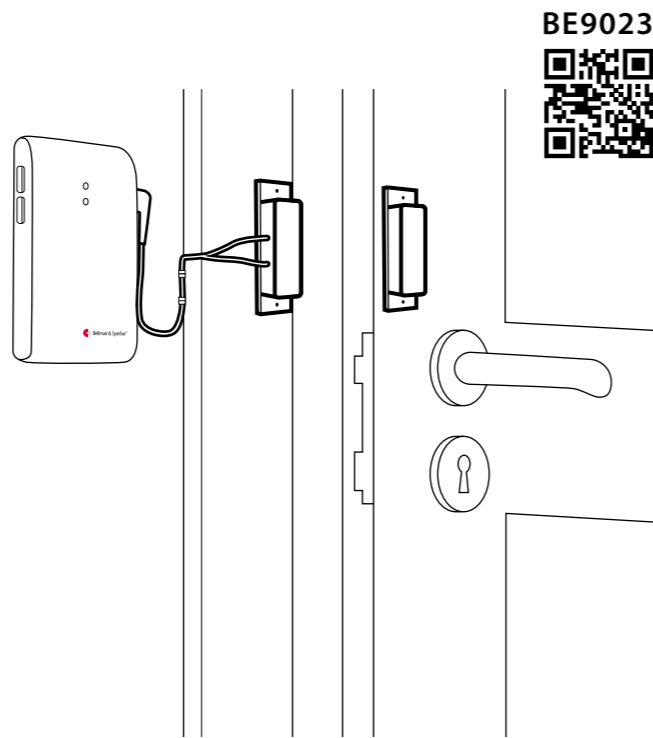

## Contact mat

### Signals when someone steps on it

Place the contact mat by the front door or by the bed and connect it to the telephone transmitter or baby monitor to be alerted when someone enters a room or leaves the bed.

### Technical specifications

- Dimensions 540×395×4.6 mm, 28"×15"×0.1"
- Weight 255 g, 9 oz.
- Connector 3.5 mm mono jack plug
- Cable length 200 cm, 6.6'
- Dust proof and sealed to IP65 (not waterproof)

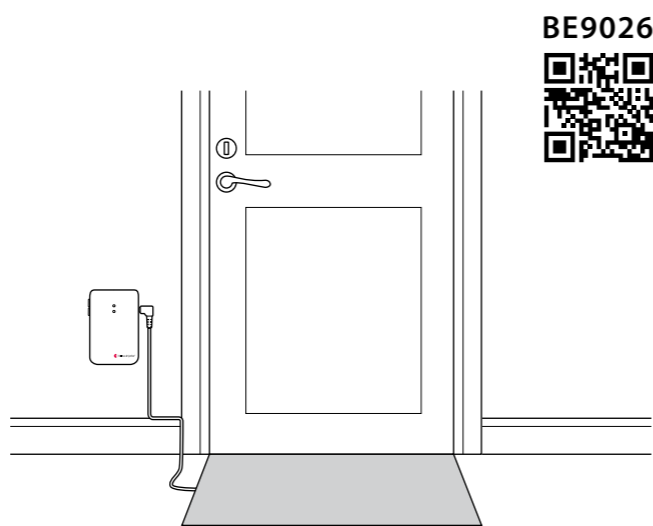

### Operation

- Contact N/O normally open
- Contact resistance 1 Ω (depending on pressure)
- Operating pressure Nominal 25 kg over 50 mm disc.
- Temperature range -5 to 65 °C, 5 to 149 °F

### Maximum ratings

- Contact rating 10 VA
- Switching voltage 25 VDC
- Switching current 0.25 Amps DC resistive
- Carry current 0.25 Amps DC resistive

## External microphone

### Extends the door transmitter reach

The external microphone can be used with the door transmitter when the sound source is located too far away from the internal microphone or when you need individual notifications from for example the doorbell and intercom.

### Technical specifications

- Dimensions 33×36×4 mm, 1.3"×1.4"×0.2"
- Weight 15 g, 0.5 oz.
- Connector 3.5 mm mono jack plug
- Cable length BE9199: 2.5 m, 8.2'  
BE9200: 0.75 m, 2.5'
- Microphone type Piezoelectric
- Colour White
- Environment For indoor use only

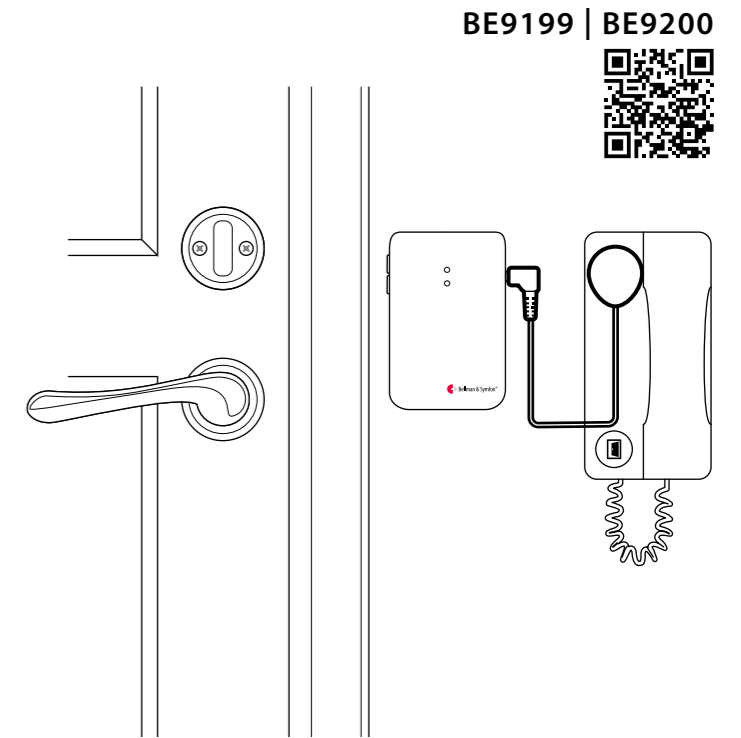

## External trigger cable

### Connects an external trigger source to Visit

The external trigger cable is used to connect an external trigger source to a Visit product. Use it for instance to connect an existing doorbell to the telephone transmitter and be alerted when someone rings the doorbell.

### Technical specifications

- Weight 25 g, 0.9 oz.
- Connector 3.5 mm mono jack plug
- Cable length 0.5 m, 1.6'
- Colour White

### Voltage

- Ⓢ 2 – 30 VDC
- 3 – 24 VAC

See the relevant Visit product section for detailed information.

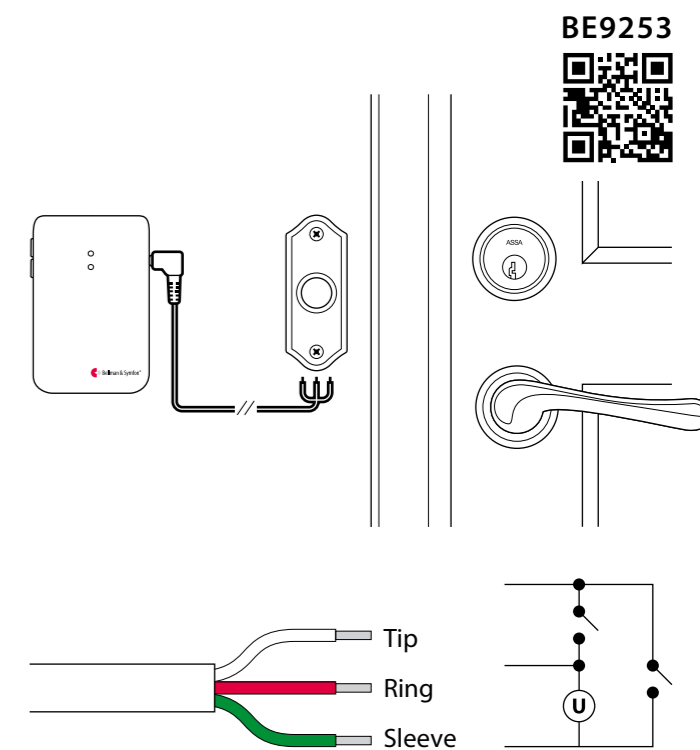



For more than 25 years Bellman & Symfon of Sweden has been dedicated to improve the quality of life for people with hearing- and care related needs. Our people and partners are devoted to this mission and we work closely with healthcare professionals and leading experts to make an easy and independent living possible for everyone.

Bellman & Symfon  
Södra Långebergsgatan 30  
436 32 Askim  
Sweden  
Phone +46 31 68 28 20  
Fax +46 31 68 28 90  
Email [info@bellman.com](mailto:info@bellman.com)

Visit\_001ART006\_EN

© and TM 2019, Bellman & Symfon AB, all rights reserved. Bellman Visit and Bellman & Symfon are registered trademarks owned by Bellman & Symfon AB.



[bellman.com](https://bellman.com)