



The Viking Electronics Elevator Emergency Phones are designed to provide quick, reliable communication to emergency personnel.

Models **K-1500-E** and **K-1500-EHF** can initiate ring-down circuits or automatically dial a preprogrammed number when the handset is lifted (**K-1500-E**) or when the emergency button is pressed (**K-1500-EHF**) - use with the Viking **K-1500-4** One Number Dialer. Both models eliminate the need for Touch-Tone or dial pads and complicated operational directions. The **K-1500-ER** is the same as the **K-1500-E**, although offers a built-in ringer.

The **K-1500-E** and **K-1500-EHF** components conform to industry-set standards, mounting on a heavy-gauge formed metal panel and finished in red baked enamel.

## STANDARD EMERGENCY FEATURES

- Handset or handsfree models available.
- Line powered.
- No Touch-Tone® or dial pads; no confusing instructions.
- Conspicuous red baked enamel finish.
- Hearing aid compatible handset.
- Interfaces with Viking **One-Number Dialer** (Model K-1500-4) when using a C.O., Centrex, or P.B.X. circuit; up to 5 of the **K-1500(E/EHF/ER)** phones may be connected to one **K-1500-4** dialer. The **K-1500-4** requires the **PG-1 Programmer** to program emergency number.
- Designed for flush mounting in elevator cabs, lobbies, hallways, garage, and entryways.
- Built for easy installation and simple operation.
- **K-1500-EHF** features push button calling and handsfree operation. Additional features include automatic 2 minute timer, ring detection, and can provide emergency personnel with the ability to call the caller again.

## SPECIFICATIONS

### DIMENSIONS:

Panel size 6<sup>7</sup>/<sub>8</sub>" X 9<sup>7</sup>/<sub>8</sub>" X 2<sup>1</sup>/<sub>2</sub>"

Mounting Holes: .235"

Use (2) 6-32 X 3/8" black oval-head screws

### WEIGHT:

2.5 lbs. (K-1500-E)

2 lbs. (K-1500-EHF)

### COLOR:

Red baked enamel with white lettering.

### POWER:

Line powered.

### ENVIRONMENTAL:

10° to 90°F with 5% to 95% non-condensing relative humidity.

### CONNECTION/INTERFACE:

Standard tip and ring.

*Made In The U.S.A.*

The Viking K-1500-E/K-1500-EHF is ideal for elevator applications as well as campus grounds, parking ramps, residential applications, nursing homes, highway applications or any area where emergency communication may be required and a standard telephone may not be desired.

The K-1500-E/K-1500-EHF can be connected to a PBX ring down circuit to provide instant ring and station identification to a security office. Or, the K-1500-E/K-1500-EHF can be used in conjunction with a Viking Hot Line dialer connected to a normal C.O. line. When used with a hot line dialer, the K-1500-E/K-1500-EHF will initiate the dialing sequence (up to 15 digits).

The K-1500-EHF will remain connected to the line for two minutes during which time the user(s) may converse in the handsfree mode with the security personnel. The handsfree operation of the K-1500-EHF offers higher security and cannot be compromised by vandals removing the handset.

After the two minute time-out, the K-1500-EHF will shut off. This automatic time-out and reset feature reduces the time and effort of the security staff in the event of prank and/or false alarms.

The K-1500-EHF contains a ring sensor which allows security personnel to initiate a silent call to monitor the location or converse with the users.

## EMERGENCY AND ELEVATOR APPLICATION

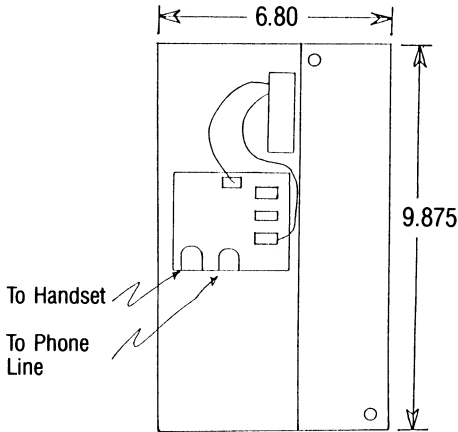

Rear View  
K-1500-E

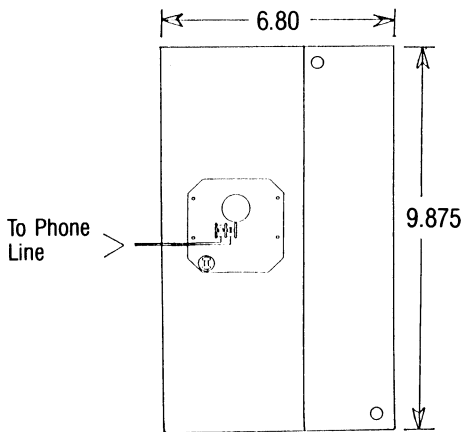

Rear View  
K-1500-EHF

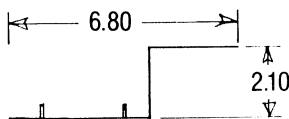

Bottom View

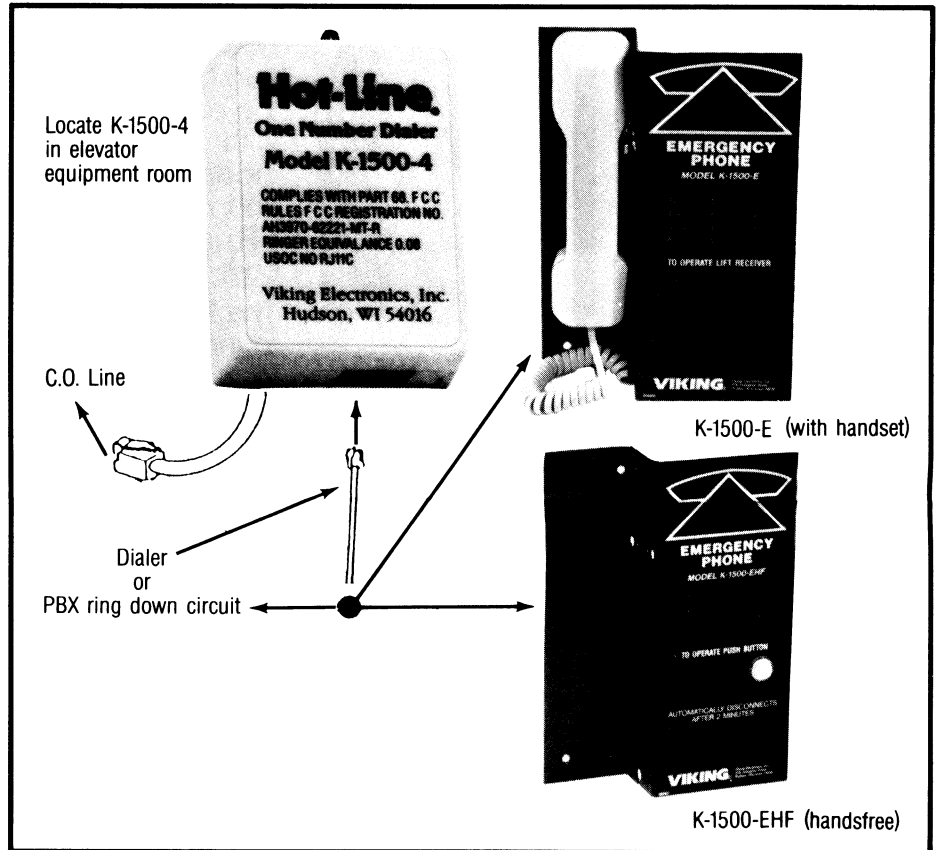

### CAUTION

This product is designed and built utilizing electronic industry practices. When installed properly this product will provide reliable service for years to come. This product is designed to be mounted in or on enclosures suitable for outside electrical installations!

This product will fail if water is allowed to accumulate or to condense in the form of droplets directly on the electronic components or the circuit board!

Electronic equipment is subject to damage from electrical surges, storms and static electricity. We recommend regular testing of the system to ensure operational integrity!

#### LIMITED ONE YEAR WARRANTY

If, at any time during the warranty period, the product is defective or malfunctions, Viking shall repair or replace it (at Viking's option) within a reasonable period of time. If the product is defective, package it carefully, along with proof of purchase (including date of purchase) along with \$5.00 for return postage and handling and a short description of the malfunction, and mail it, postage prepaid, to the following address:

Manager-Product Service, Viking Electronics, Inc., Post Office Box 448, 1531 Industrial Street, Hudson, WI 54016

This warranty does not cover any damage due to accident, misuse, abuse or negligence. Viking's sole responsibility shall be to repair or replace the product within the terms stated above. VIKING SHALL NOT BE LIABLE FOR ANY LOSS OR DAMAGE OF ANY KIND, INCLUDING ANY INCIDENTAL OR CONSEQUENTIAL DAMAGES RESULTING DIRECTLY OR INDIRECTLY FROM ANY BREACH OF ANY WARRANTY, EXPRESSED OR IMPLIED, OR FOR ANY OTHER FAILURE OF THIS PRODUCT. Some states do not allow the exclusion or limitation of incidental or consequential damages, so this limitation may not apply to you.

THIS WARRANTY IS IN LIEU OF ALL OTHER WARRANTIES, EXPRESSED OR IMPLIED, INCLUDING THE WARRANTIES OF MERCHANTABILITY AND FITNESS FOR A PARTICULAR PURPOSE, WHICH ARE HEREBY EXCLUDED BEYOND THE ONE YEAR DURATION OF THIS WARRANTY. Some states do not allow limitations on how long an implied warranty lasts, so the above limitation may not apply to you.

This warranty gives you specific legal rights, and you may have other rights which vary from state to state. If you have any questions concerning this warranty, or the product, contact your dealer or write to us at the above address.