

Panasonic®

Quick Guide

Digital Cordless Answering System

Model No. **KX-TGK220E**



Thank you for purchasing a Panasonic product.

Please read this document before using the unit and save it for future reference.

For detailed information about the features of your phone system, refer to the Operating Instructions, Which is available by visiting the support page for this product at the address below.

<http://www.panasonic.eu>

Introduction

Accessory information

Supplied accessories

No.	Accessory item/Part number	Quantity
①	AC adaptor/PNLV226E0X	1
②	Telephone line cord/PNJA1191Z (Black/for U.K.)	1
③	Rechargeable batteries*1	2
④	Handset cover	1

*1 Please read the operating instructions for replacement battery information.

Note:

- Please read the operating instructions for additional/replacement accessories.

Expanding your phone system

Handset (optional): KX-TGDA30E

You can expand your phone system by registering optional handsets (6 max.) to a single base unit.

- Optional handset is a different design from that of the supplied handsets.



Note:

- You can purchase KX-TGK220 separately and use it as an optional handset. Please read the operating instructions for details.

Sales and support information

Customer Communications Centre

- For customers within the U.K.: 0344 844 3899
- For customers within Ireland: 01289 8333
- For further support on your product, please visit our website: www.panasonic.co.uk

Direct Sales at Panasonic U.K.

- Order accessory and consumable items for your product with ease and confidence by phoning our Customer Communications Centre Monday - Friday 9:00am - 5:00pm (Excluding public holidays).
- Go on line through our Internet Accessory ordering application at www.pas-europe.com
- Most major credit and debit cards accepted.

- All enquiries transactions and distribution facilities are provided directly by Panasonic U.K.
- Also available through our Internet is direct shopping for a wide range of finished products. Take a browse on our website for further details.
shop.panasonic.co.uk/

General information

- This equipment is designed for use on the U.K. and Ireland analogue telephone network.
- In the event of problems, you should contact your equipment supplier in the first instance.

Declaration of Conformity:

- Panasonic Corporation declares that the radio equipment type (KX-TGK220) is in compliance with Directive 2014/53/EU. The full text of the EU declaration of conformity is available at the following internet address:

<http://www.ptc.panasonic.eu/doc>

Contact to Authorised Representative:

Panasonic Testing Centre
Panasonic Marketing Europe GmbH
Winsbergring 15, 22525 Hamburg, Germany

Ecodesign information

Ecodesign information under EU Regulation (EC) No. 1275/2008 amended by (EU) Regulation No. 801/2013. From 1 January 2015.

Please visit here: <http://www.ptc.panasonic.eu/erp>













Click [Downloads]

→ Energy related products information (Public)

Power consumption in networked standby and guidance are mentioned in the web site above.

Introduction

Graphical symbols for use on equipment and their descriptions

Symbol	Explanation	Symbol	Explanation
	Alternating current (A.C.)		Class II equipment (equipment in which protection against electric shock relies on Double Insulation or Reinforced Insulation)
	Direct current (D.C.)		"ON" (power)
	Protective earth		"OFF" (power)
	Protective bonding earth		Stand-by (power)
	Functional earth		"ON"/"OFF" (power; push-push)
	For indoor use only		Caution, risk of electric shock

For your future reference

We recommend keeping a record of the following information to assist with any repair under warranty.

Serial No.	Date of purchase
(found on the bottom of the base unit)	
Name and address of dealer	

For your safety

To prevent severe injury and loss of life/property, read this section carefully before using the product to ensure proper and safe operation of your product.

WARNING

Power connection

- Use only the power source marked on the product.
- Do not overload power outlets and extension cords. This can result in the risk of fire or electric shock.
- Completely insert the AC adaptor/power plug into the power outlet. Failure to do so may cause electric shock and/or excessive heat resulting in a fire.
- Regularly remove any dust, etc. from the AC adaptor/power plug by pulling it from the power outlet, then wiping with a dry cloth. Accumulated dust may cause an insulation defect from moisture, etc. resulting in a fire.
- Unplug the product from power outlets if it emits smoke, an abnormal smell, or makes an unusual noise. These conditions can cause fire or electric shock. Confirm that smoke has stopped emitting and contact an authorised service centre.
- Unplug from power outlets and never touch the inside of the product if its casing has been broken open.
- Never touch the plug with wet hands. Danger of electric shock exists.

Installation

- To prevent the risk of fire or electrical shock, do not expose the product to rain or any type of moisture.
- Do not place or use this product near automatically controlled devices such as automatic doors and fire alarms. Radio waves emitted from this product may cause such devices to malfunction resulting in an accident.

- Do not allow the AC adaptor or telephone line cord to be excessively pulled, bent or placed under heavy objects.

Operating safeguards

- Unplug the product from power outlets before cleaning. Do not use liquid or aerosol cleaners.
- Do not disassemble the product.
- Do not spill liquids (detergents, cleansers, etc.) onto the telephone line cord plug, or allow it to become wet at all. This may cause a fire. If the telephone line cord plug becomes wet, immediately pull it from the telephone wall jack, and do not use.

Medical

- Consult the manufacturer of any personal medical devices, such as pacemakers or hearing aids, to determine if they are adequately shielded from external RF (radio frequency) energy. (The product operates in the frequency range of 1.88 GHz to 1.90 GHz, and the RF transmission power is 250 mW (max.))
- Do not use the product in health care facilities if any regulations posted in the area instruct you not to do so. Hospitals or health care facilities may be using equipment that could be sensitive to external RF energy.

CAUTION

Installation and location

- Never install telephone wiring during an electrical storm.
- Never install telephone line jacks in wet locations unless the jack is specifically designed for wet locations.
- Never touch uninsulated telephone wires or terminals unless the telephone line has been disconnected at the network interface.
- Use caution when installing or modifying telephone lines.
- The AC adaptor is used as the main disconnect device. Ensure that the AC outlet is installed near the product and is easily accessible.

Important Information

Battery

- We recommend using the batteries noted in the operating instructions.
- Do not mix old and new batteries.
- Do not open or mutilate the batteries. Released electrolyte from the batteries is corrosive and may cause burns or injury to the eyes or skin. The electrolyte is toxic and may be harmful if swallowed.
- Exercise care when handling the batteries. Do not allow conductive materials such as rings, bracelets, or keys to touch the batteries, otherwise a short circuit may cause the batteries and/or the conductive material to overheat and cause burns.
- Charge the batteries provided with or identified for use with this product only, in accordance with the instructions and limitations specified in the operating instructions.
- Only use a compatible base unit (or charger) to charge the batteries. Do not tamper with the base unit (or charger). Failure to follow these instructions may cause the batteries to swell or explode.

Important safety instructions

When using your product, basic safety precautions should always be followed to reduce the risk of fire, electric shock, and injury to persons, including the following:

1. Do not use this product near water for example, near a bathtub, washbowl, kitchen sink, or laundry tub, in a wet basement or near a swimming pool.
2. Avoid using a telephone (other than a cordless type) during an electrical storm. There may be a remote risk of electric shock from lightning.
3. Do not use the telephone to report a gas leak in the vicinity of the leak.
4. Use only the power cord and batteries indicated in the operating instructions. Do not dispose of batteries in a fire. They may explode. Check with local codes for possible special disposal instructions.

SAVE THESE INSTRUCTIONS

Other information

CAUTION: Risk of explosion if battery is replaced by an incorrect type. Dispose of used batteries according to the instructions.

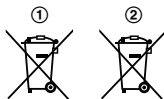

These symbols (①, ②) indicate separate collection of waste electrical and electronic equipment. More detailed information is contained in "Operating Instructions for advanced features (PDF format)".

Specifications

- **Standard:**
DECT (Digital Enhanced Cordless Telecommunications),
GAP (Generic Access Profile)
- **Frequency range:**
1.88 GHz to 1.90 GHz
- **RF transmission power:**
Approx. 10 mW (average power per channel)
250 mW (max.)
- **Power source:**
100–240 V AC, 50/60 Hz
- **Power consumption:**
Base unit:
Standby: 0.5 W
Maximum: 2.5 W
- **Operating conditions:**
0 °C–40 °C, 20 %–80 % relative air humidity (dry)

Setting up

Connections

■ Base unit

- ① Connect the AC adaptor to the unit by pressing the plug firmly.
- ② Connect the AC adaptor to the power outlet.
- ③ Connect the telephone line cord to the unit, then to the telephone line jack until you hear a click.
- ④ Fasten the cord by hooking it.
- ⑤ A DSL/ADSL filter (not supplied) is required if you have a DSL/ADSL service.

Note:

- Use only the supplied Panasonic AC adaptor PNLV226E.
- Use only the supplied telephone line cord.

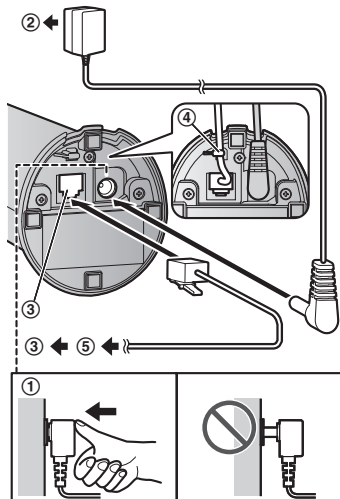

Battery installation/setting the handset cover

- USE ONLY rechargeable Ni-MH batteries AAA (R03) size (A).
- Do NOT use alkaline/manganese/Ni-Cd batteries.
- Confirm correct polarities (⊕, ⊖).

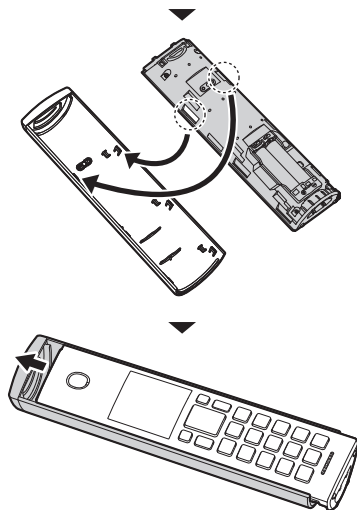
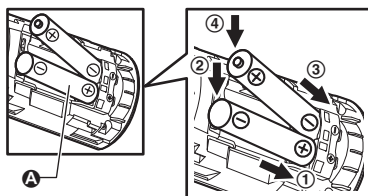

- Follow the directions on the display to set up the unit.

Getting Started

Battery charging

Charge for about 7 hours.

- When the handset is placed on the base unit, a beep is heard and the message indicator lights up about 5 seconds.

Ni-MH battery performance (supplied batteries)

Operation	Operating time
In continuous use	18 hours max.
Not in use (standby)	200 hours max.

Note:

- Actual battery performance depends on usage and ambient environment.

Controls

Base unit

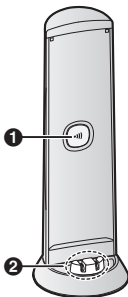

- 1 **[•••]] (Locator)**
 - You can locate a misplaced handset by pressing [•••]].
- 2 **Charge contacts**

Handset

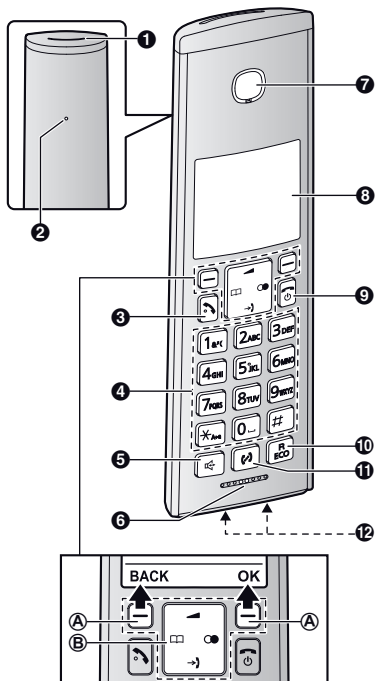

- 1 **Speaker**
 - 2 **Message indicator**
 - 3 **[☎] (Talk)**
 - 4 **Dial keypad**
 - 5 **[☎] (Speakerphone)**
 - 6 **Microphone**
 - 7 **Receiver**
 - 8 **Display**
 - 9 **[⏻] (Off/Power)**
 - 10 **[R/ECO]**
R: Recall/Flash
ECO: Eco mode shortcut key
 - 11 **[☎] (Intercom)**
 - 12 **Charge contacts**
- Control type
Ⓐ Soft keys

By pressing a soft key, you can select the feature shown directly above it on the display.

(Example: MENU, OK, etc.)

B Navigator key

Navigator keys functions as follows.

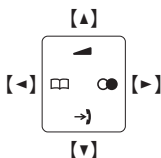

- [▲], [▼], [◀], or [▶]: Scroll through various lists and items.
- [▲] or [▼] (▲): Adjust the receiver or speaker volume while talking.
- [→] (Caller list): View the caller list.
- [☐] (Phonebook): View the phonebook entry.
- [●] (Redial): View the redial list.

Display icons

Handset display items

Item	Meaning
	Range status: The more bars visible, the closer the handset is to the base unit.
	Out of base unit range
	Paging, intercom mode
	Speakerphone is on. (page 10)
	The line is in use. <ul style="list-style-type: none"> • When flashing slowly: The call is on hold. • When flashing rapidly: An incoming call is now being received.

Item	Meaning
	<ul style="list-style-type: none"> • When displayed next to the battery icon: Answering system is on. • When displayed with a number: New messages have been recorded.
	Battery level
	Ringer volume is off.

Handset soft key icons

Icon	Action
OK	Accepts the current selection.
	Opens the phonebook.

■ When you select a language other than English

Icon	Action
	Returns to the previous screen or outside call.
	Displays the menu.
	Makes a call.
	Stops recording or playback.
C	Erases a number/character.
	Puts the call on mute.

Language setting

Display language

- 1 [MENU]#1110
- 2 [↕]: Select your desired language. → [OK] → [📞]

Date and time

- 1 [MENU]#1011

Getting Started

- Enter the current date, month, and year.
→ [OK]
Example: 12 July, 2017
[1][2] [0][7] [1][7]
- Enter the current hour and minute.
Example: 9:30
[0][9] [3][0]
 - You can select 24-hour or 12-hour clock format (“AM” or “PM”) by pressing [X].
- [OK] → [📞]

Recording your greeting message

- [MENU][#][3][0][2]
- [↕]: “Yes” → [OK]
- Record a greeting message. → [STOP] → [📞]

Making calls

- Lift the handset and dial the phone number.
 - To correct a digit, press [CLEAR].
- Press [📞] to make the call.
 - To make the call using the speakerphone, press [📞].
- When you finish talking, press [📞] or place the handset on the base unit or charger.

Note:

- To switch to the speaker, press [📞].
- To switch back to the receiver, press [📞]/[📞].

Adjusting the receiver or speaker volume

Press [▲] or [▼] repeatedly while talking.

Making a call using the redial list

- [📞]

- [↕]: Select the desired entry.
- [📞]

Answering calls

- Lift the handset and press [📞] or [📞] when the unit rings.
- When you finish talking, press [📞] or place the handset on the base unit or charger.

Adjusting the ringer volume

Press [▲] or [▼] repeatedly to select the desired volume while ringing.

Phonebook

Adding phonebook entries

- [☐] → [MENU]
- [↕]: “New Entry” → [OK]
- Enter the party's name. → [OK]
 - You can change the character entry mode by pressing [R/ECO].
- Enter the party's phone number. → [OK]
- [↕]: Select the desired category. → [OK]
- [OK] → [📞]

Calling from a phonebook entry

- [☐]
- [↕]: Select the desired entry.
- [📞]

Answering system









Turning the answering system on/off

- 1 To turn on:
[MENU]#327
To turn off:
[MENU]#328
- 2 [

Listening to messages

- 1 To listen to new messages:
[MENU]#323
To listen to all messages:
[MENU]#324
- 2 When finished, press [].

Troubleshooting

Problem	Cause/solution
The handset does not turn on even after installing charged batteries.	<ul style="list-style-type: none">● Place the handset on the base unit or charger to turn on the handset.
I fully charged the batteries, but <ul style="list-style-type: none">–  still flashes or– the operating time seems to be shorter.	<ul style="list-style-type: none">● Clean the battery ends (\oplus, \ominus) and the charge contacts with a dry cloth and charge again.● It is time to replace the batteries (page 7).
 is displayed.	<ul style="list-style-type: none">● The handset is too far from the base unit. Move closer.● The base unit's AC adaptor is not properly connected. Reconnect AC adaptor to the base unit.● The handset is not registered to the base unit. Register it (page 13).
Noise is heard, sound cuts in and out.	<ul style="list-style-type: none">● You are using the handset or base unit in an area with high electrical interference. Re-position the base unit and use the handset away from sources of interference.● Move closer to the base unit.● If you use a DSL/ADSL service, we recommend connecting a DSL/ADSL filter between the base unit and the telephone line jack. Contact your DSL/ADSL provider for details.
 is shown on the handset display. How do I remove this icon from the display?	<ul style="list-style-type: none">● Press [] for about 3 seconds.
What is a PIN?	<ul style="list-style-type: none">● The PIN is a 4-digit number that must be entered in order to change certain base unit settings. The default PIN is "0000".
Caller information is not displayed.	<ul style="list-style-type: none">● You must subscribe to a Caller ID service. Contact your phone service provider for details.
 is shown on the handset display. How do I remove this icon from the display?	<ul style="list-style-type: none">● View the unviewed missed calls.● Place the handset on the base unit or charger.● Press [].
 is shown on the handset display. How do I remove this icon from the display?	<ul style="list-style-type: none">● Listen your new voicemail messages. Depending on your voicemail service provider, you may need to erase all messages in your voice mailbox in order to remove this message.● You can remove this message manually by pressing and holding [] until the unit beeps.

Registering a handset to a base unit

The supplied handset and base unit are pre-registered. If for some reason the handset is not registered to the base unit, re-register the handset.

- 1 Handset:**
[MENU]#130
- 2** [↕]: Select a base unit number. → [OK]
- 3 Base unit:**
Press and hold [•••••] for about 5 seconds.
- 4 Handset:**
[OK] → Wait until "Base PIN" is displayed. → Enter the base unit PIN (default: "0000").
→ [OK]

Other Information

Conditions of guarantee

This guarantee is in addition to and does not in any way affect any statutory or other rights of consumer purchasers. If within the applicable guarantee period, the product proves to be defective by reason of faulty design, workmanship or materials, we undertake subject to the following conditions to have the defective product (or any part or parts thereof) repaired or replaced free of charge.

1. The product shall have been purchased and used solely within either the U.K. or Ireland and in accordance with standard operating instructions and the technical and/or Safety Standards required in the U.K.
2. On being found defective, please consult with the retailer from where it was purchased for assistance.
3. This guarantee shall not apply to damage caused through fire, accident, lightning, misuse, wear and tear, neglect, incorrect adjustment or repair, to damage caused through installation, adaption, modification or use in an improper manner or inconsistent with the technical and/or safety standards required in the country where this product is used, or to damage occurred during transit to or from the purchaser.
4. If at any time during the guarantee period any part or parts of the product are replaced with a part or parts not supplied or approved by us or of an objective quality safe and suitable for the product, or the product has been dismantled or repaired by any person not authorised by us, we shall have the right to terminate this guarantee in whole or in part immediately without further notice.
5. The purchaser's sole and exclusive remedy under this guarantee against us is for the repair or replacement of the product or any defective part or parts and no other remedy, including, but not limited to, incidental or consequential damage or loss of whatsoever nature shall be available to the purchaser.
6. This guarantee shall not apply to batteries and any other items of limited natural life.
7. Our decision on all matters relating to complaints shall be final. Any product or defective part which has been replaced shall become our property.
8. The guarantee period applicable to this product shall be 12 months.

Please keep these operating instructions with your receipt.

Panasonic U.K. a branch of Panasonic Marketing Europe GmbH

Receipt No. _____	Date of purchase _____
Model No. _____	Serial No. _____

IMPORTANT!

If your product is not working properly. . .

- ① **Reconnect AC adaptor to the base unit.**
- ② **Check if telephone line cord is connected.**
- ③ **Use rechargeable Ni-MH batteries.**
(Alkaline/Manganese/Ni-Cd batteries CANNOT be used.)
- ④ Read **troubleshooting** page in the **Operating Instructions**.



If you still have any problems, please call the Panasonic
DECT Helpline

0344 844 3899 (U.K.)

01289 8333 (Ireland)

or contact us through our website:

www.panasonic.co.uk

Sales Department:

Panasonic U.K. a branch of
Panasonic Marketing Europe GmbH

Panasonic House, Willoughby Road, Bracknell, Berkshire, RG12 8FP

Panasonic Corporation

1006, Oaza Kadoma, Kadoma-shi, Osaka 571-8501, Japan
<http://www.panasonic.com>

© Panasonic Corporation 2017



PNQW5377ZA

PNQW5377ZA PP0317AM0