

## Four Zone Paging Interface

The **ZPI-4** is a four-zone touch tone controlled paging system capable of switching a line level signal (600 ohms) to amplifiers, an amplified signal to 70V speakers, or an amplified signal (200 watts maximum) to 8 ohm speakers.

The **ZPI-4** features balanced audio circuitry throughout for low noise and compatibility with balanced paging system inputs and outputs. There are separate level controls for paging and background music, and background music can be disabled on a per-zone basis. Also provided is a night bell with adjustable volume activated by a dry contact closure or a ringing analog PABX/KSU station.

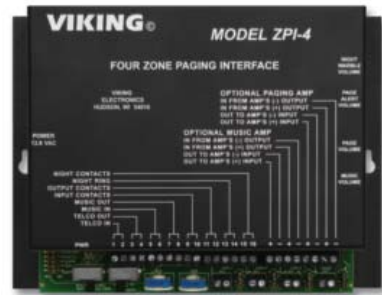

The **ZPI-4** is compatible with ringing analog PABX/KSU station ports (disconnects on silence, CPC, busy, Touch Tone (#) or time-out) as well as unused trunk inputs, and will interface directly with standard paging ports.

### Features

- Touch Tone control of four zones, expandable to 8 zones
- Switches line level signal to amplifiers or amplified signal to speakers (amplifier(s) not included)
- Balanced audio circuitry for low noise
- Night bell warble with adjustable level from contact closure or ringing analog station
- Input provided for background music
- Separate paging and background music level adjustments
- Background music automatically mutes in paged zone(s) in all but single amplifier mode
- All-call and five group call patterns, selected by Touch Tones
- Selectable page alert tone with adjustable level
- Interfaces with ringing analog station ports, paging ports and unused phone system trunk ports
- Disconnects on silence, CPC, busy, touch tone "# or time-out
- Screw terminals for all input/output connections

### Applications

- Multiple zone paging for phone systems with paging ports, unused analog station ports or unused trunk inputs
- Multiple department manufacturing business
- Multi-level warehouse
- Multiple building office complex

[www.vikingelectronics.com](http://www.vikingelectronics.com)  
Information: (715) 386-8861

### Specifications

**Power:** 120V AC/13.8V AC, 1.25A adapter provided  
**Dimensions:** 211mm x 160mm x 46mm (8.30" x 6.30" x 1.80")  
**Shipping Weight:** 1.5 kg (3.2 lbs)  
**Environmental:** 0° C to 32° C (32° F to 90° F) with 5% to 95% non-condensing humidity  
**Relay Contacts:** 5 Amps@30V DC/250V AC each (350W@70V)  
**REN:** 0.5 A  
**Artificial Talk Battery Voltage:** 24V DC  
**Connections:** (32) cage clamp screw terminals

# Features Overview

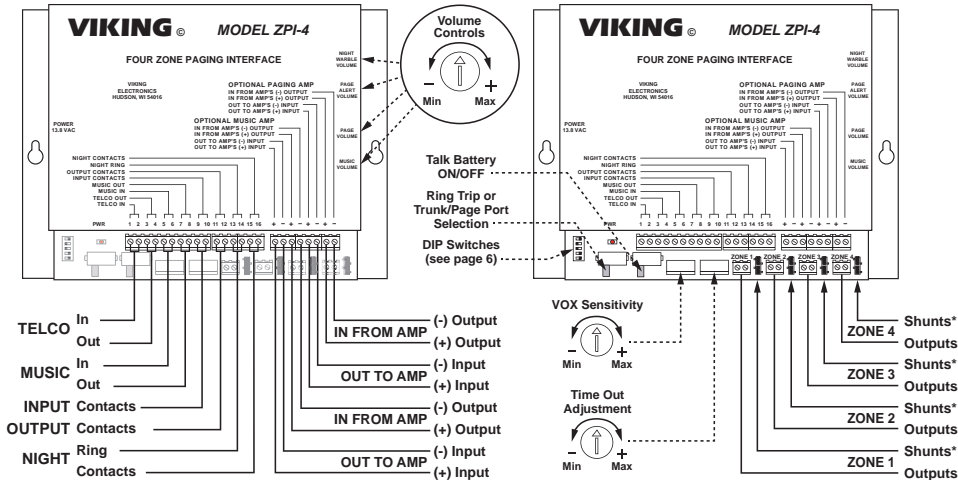

\* Note: Remove these shunts to eliminate background music for each zone individually (except Single Amplifier Mode).

# Installation and Programming

**IMPORTANT:** Electronic devices are susceptible to lightning and power station electrical surges from both the AC outlet and the telephone line. It is recommended that a surge protector be installed to protect against such surges.

## A. System Interface

### 1. Ring Trip Paging

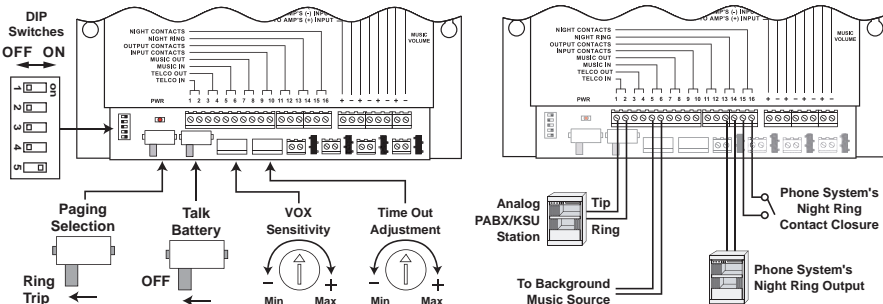

<b>Step 1.</b>	Set the RING TRIP/TRUNK/PAGE PORT switch to the RING TRIP position (all the way to the left).
<b>Step 2.</b>	Set the TALK BATT switch to the OFF position (all the way to the left).
<b>Step 3.</b>	Attach TIP and RING to the TELCO IN screw terminals.
<b>Step 4.</b>	Attach the background music source, if used, to the MUSIC IN screw terminals.
<b>Step 5.</b>	Adjust the TIME OUT ADJUST as required (adjustable from approximately 5 seconds to 80 seconds). This should be set to a second or two longer than the longest expected page. The ZPI-4 hangs up when this timer is up, and if the timer is set for too short a time, the ZPI-4 will hang up in the middle of a page. <b>Notes:</b> The VOX SENSITIVITY probably will not have to be adjusted unless the ZPI-4 is disconnecting in the middle of a page, before the time out or there is a period of silence during a page longer than three seconds and the ZPI-4 does not auto-disconnect. To adjust the VOX SENSITIVITY, turn the POT counter clockwise to decrease the VOX sensitivity and clockwise to increase it. The VOX SENSITIVITY should be increased if the ZPI-4 is auto-disconnecting in the middle of pages, and decreased if it is not auto-disconnecting on busy signals or periods of silence more than three seconds.
<b>Step 6.</b>	If the phone system provides a contact closure for night ring, connect a pair of wires from this closure to the NIGHT CONTACTS screw terminals. If the phone system provides ring signal for night ring, hook up a pair of wires from the phone system night ring output to the NIGHT RING screw terminals.
<b>Step 7.</b>	Dial tone and page alert tone may be enabled as shown in DIP switch programming.

## 2. Paging from an Unused Phone System Trunk Port

**Note:** In this mode, the ZPI-4's time out and VOX sensitivity are disabled. The ZPI-4 will release the trunk as soon as the paging party hangs up.

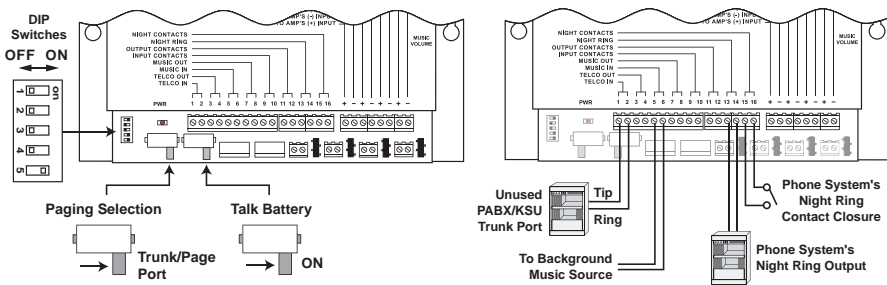

<b>Step 1.</b>	Set the RING TRIP/TRUNK/PAGE PORT switch to the TRUNK/PAGE PORT position (all the way to the right).
<b>Step 2.</b>	Set the TALK BATT switch to the ON position (all the way to the right).
<b>Step 3.</b>	Attach the unused trunk port to the TELCO IN screw terminals.
<b>Step 4.</b>	Attach the background music source, if required, to the MUSIC IN screw terminals.
<b>Step 5.</b>	If the phone system provides a contact closure for night ring, connect a pair of wires from this closure to the NIGHT CONTACTS screw terminals. If the phone system provides ring signal for night ring, hook up a pair of wires from the phone system night ring output to the NIGHT RING screw terminals.
<b>Step 6.</b>	If the phone system provides a contact closure for night ring, connect a pair of wires from this closure to the NIGHT CONTACTS screw terminals. If the phone system provides ring signal for night ring, hook up a pair of wires from the phone system night ring output to the NIGHT RING screw terminals.
<b>Step 7.</b>	Dial tone and Page alert tone may be enabled as shown in DIP Switch Programming.

## 3. Paging from a Phone System's 600 Ohm Paging Port

**Note:** You must be able to send Touch Tones through the PABX's paging port for this mode to work.

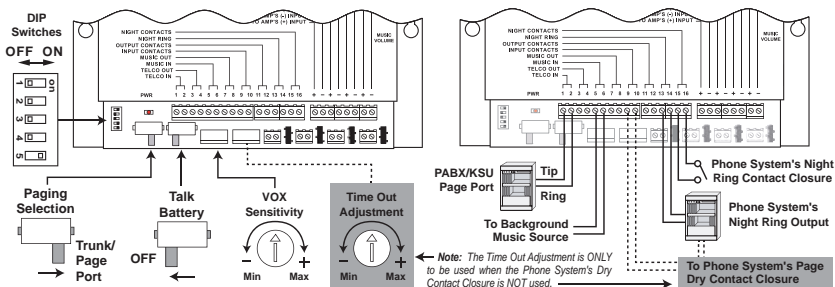

<b>Step 1.</b>	Set the RING TRIP/TRUNK/PAGE PORT switch to the TRUNK/PAGE PORT position (all the way to the right).
<b>Step 2.</b>	Set the TALK BATT switch to the OFF position (all the way to the left).
<b>Step 3.</b>	Attach a pair of wires from the paging port to the TELCO IN screw terminals.
<b>Step 4.</b>	Attach the background music source, if required, to the MUSIC IN screw terminals.
<b>Step 5.</b>	<p>If the phone system provides a page dry contact closure for paging, connect a pair of wires from this closure to the INPUT CONTACTS screw terminals of the ZPI-4. In this application, the ZPI-4's time out and VOX sensitivity are disabled. The ZPI-4 will release the page port as soon as its INPUT CONTACTS open.</p> <p>If the phone system does not provide a page dry contact closure, adjust the TIME OUT ADJUST as required (adjustable from approximately 5 seconds to 80 seconds). This should be set to a second or two longer than the longest expected page. The ZPI-4 hangs up when this time is reached, and if the timer is set too short, the ZPI-4 will hang up in the middle of a page.</p> <p><b>Notes:</b> The VOX SENSITIVITY probably will not have to be adjusted unless the ZPI-4 is disconnecting in the middle of a page, before the time out or there is a period of silence during a page longer than three seconds and the ZPI-4 does not auto-disconnect.</p> <p>To adjust the VOX SENSITIVITY, turn the POT counter clockwise to decrease the VOX sensitivity and clockwise to increase it. The VOX SENSITIVITY should be increased if the ZPI-4 is auto-disconnecting in the middle of pages, and decreased if it is not auto-disconnecting on periods of silence longer than three seconds.</p>
<b>Step 6.</b>	If the phone system provides a contact closure for night ring, connect a pair of wires from this closure to the NIGHT CONTACTS screw terminals. If the phone system provides ring signal for night ring, connect a pair of wires from the phone system night ring output to the NIGHT RING screw terminals.
<b>Step 7.</b>	Put DIP switch 4 to OFF to disable the ZPI-4's dial tone.

## B. Amplifier Configuration

### 1. Four Amplifier Mode

In this mode, each paging zone has its own amplifier, and the function of the **ZPI-4** is to switch the unamplified paging or background music signal to the appropriate amplifier.

**Advantages:** There is no amplifier power limitation, zones can be set to different volumes, background music is selectable per zone and the non-paged zones will continue to get music during a page.

To set the **ZPI-4** up in the four amplifier mode:

<b>Step 1.</b>	Attach the ZONE 1 screw terminals to the input of the amplifier for Zone 1.
<b>Step 2.</b>	If background music is to be enabled on this zone, ensure that the ZONE 1 music shunts are in place, covering both pins. If not, remove the shunts.
<b>Step 3.</b>	Repeat steps 1 and 2 for each of the remaining three zones.
<b>Step 4.</b>	Install the included jumpers across the Optional Paging Amp screw terminals.
<b>Step 5.</b>	If a background music source is being used, install the Optional Background Music Amplifier jumpers as shown.
<b>Step 6.</b>	Set DIP switch 1 to OFF.
<b>Step 7.</b>	Connect Paging Amps between zone outputs and speakers.

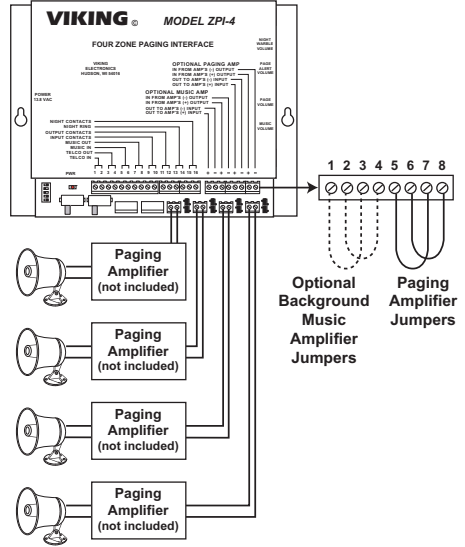

### 2. Two Amplifier Mode (Paging and Music)

In the two amplifier mode, one amp serves as the paging amplifier and the other as the background music amplifier. The paging or music signal is sent to the external amplifier, returned and the amplified signal is switched by the **ZPI-4** to the correct zone or zones.

**Advantages:** Up to a 350 watt amplifier may be used when driving 70V speakers, only (2) amplifiers (or one stereo amp) are required for 4 zones, background music is selectable per zone, and the non-paged zones will continue to get music during a page.

**Limitations:** The paging amp needs to be limited to 200 watts and the music amp needs to be limited to 70 watts when switching 8 ohm speaker loads, each speaker zone is limited to 8 ohms minimum impedance and the amp must have the ability to drive the speakers of all zones. (Example: 4 zones at 8 ohms per zone equals a 2 ohm load during an all call.)

To set up the **ZPI-4** in the two amplifier mode:

<b>Step 1.</b>	Attach the ZONE 1 screw terminals to the speaker(s) for Zone 1.
<b>Step 2.</b>	If background music is to be enabled on this zone, ensure that the ZONE 1 music shunts are in place, covering both pins. If background music is not desired, remove the shunts.
<b>Step 3.</b>	Repeat steps 1 and 2 for each of the remaining three zones.
<b>Step 4.</b>	Attach the paging amplifier and the music amplifier as shown in the diagram.
<b>Step 5.</b>	Set DIP switch 1 to OFF.

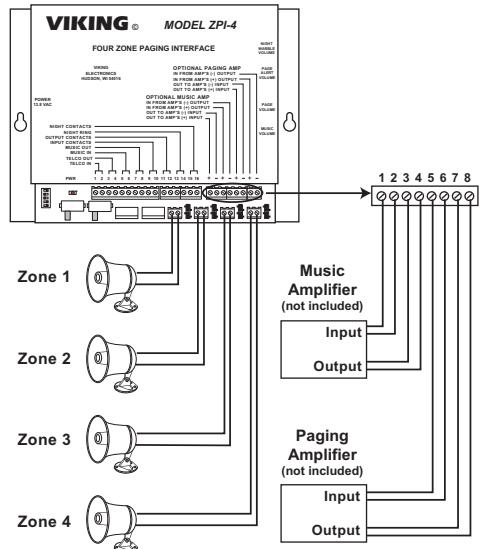

### 3. Single Amplifier Mode

In this mode, one external amplifier handles both paging and background music. An internal relay capable of switching between paging signal and music signal sends input to this amp, the amplified signal is returned and the ZPI-4 sends it to the correct zone(s).

**Advantages:** Up to a 350 watt amplifier may be used when driving 70V speakers, only one amplifier is required.

**Limitations:** The amplifier needs to be limited to 200 watts, each speaker zone is limited to an 8 ohm minimum impedance, the amplifier must be able to drive the speakers of all zones (Example: 4 zones at 8 ohms per zone equals a 2 ohm load during an all call); if background music is used, all zones will receive background music and it will be muted in all zones during a page.

To set up the ZPI-4 in the single amplifier mode:

<b>Step 1.</b>	Attach ZONE 1 screw terminals to the speaker(s) for Zone 1.
<b>Step 2.</b>	Repeat step 2 for each of the remaining three zones.
<b>Step 3.</b>	Attach the paging amp as shown in the diagram.
<b>Step 4.</b>	Set DIP switch 1 to the ON position. This tells the ZPI-4 that it is operating in the single amplifier mode.

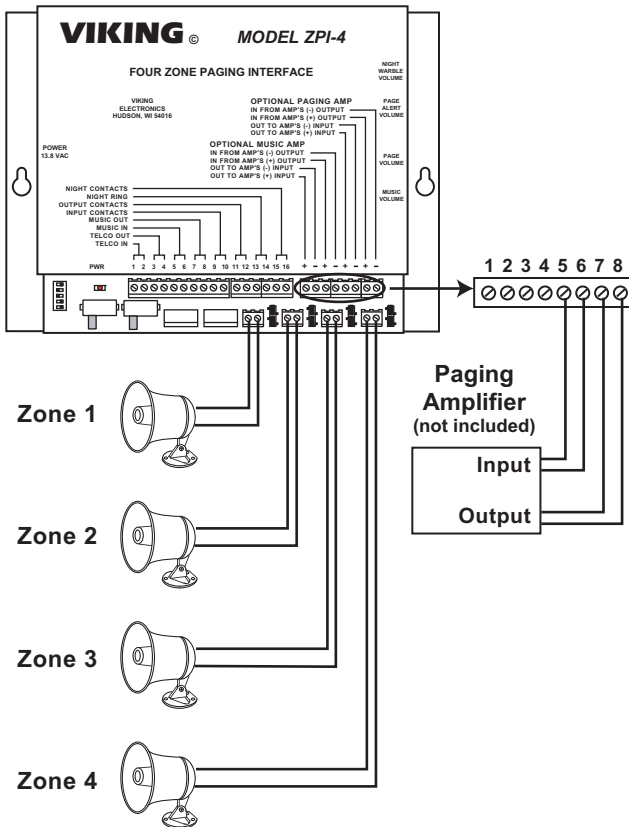

## C. Multiple Units

While the ZPI-4 is a four zone paging unit, it may be cascaded with an additional ZPI-4 for a total of up to eight paging zones. The first ZPI-4 is considered the "Master" unit, and the other unit is considered a "Slave".

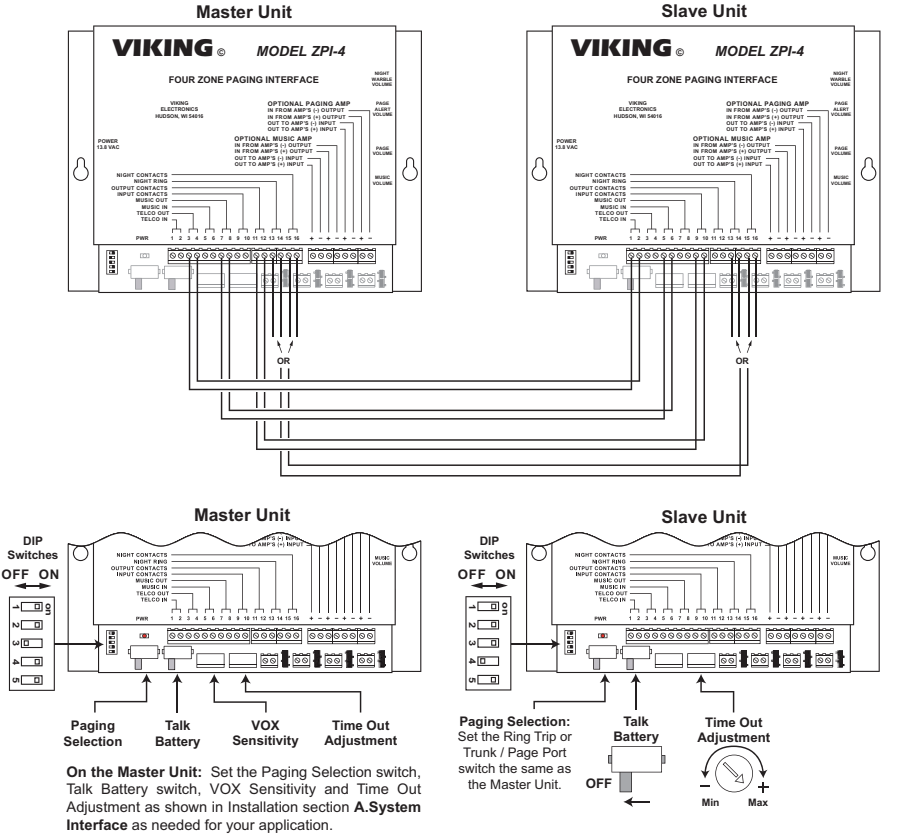

Step 1.	Install the Master unit as explained in section A. System Interface.
Step 2.	Select an amplifier mode, shown in Installation section B. Amplifier Configuration, sections 1-3.
Step 3.	Set DIP switch 2 to ON for both the Master and Slave. This sets both ZPI-4s for multiple units
Step 4.	On the Slave unit, set DIP switch 3 to ON. On the Master unit, leave OFF.
Step 5.	If dial tone is desired, set DIP switch 4 on the Master unit to ON. This will enable dial tone for both units. On the Slave unit, DIP switch 4 should remain OFF
Step 6.	To enable page alert tone, set DIP switch 5 on the master unit to ON. To disable, set DIP switch 5 on the master unit to OFF. On the slave unit, DIP switch 5 should be set to OFF. <b>Note:</b> The master's page alert volume will control the slave's zones.
Step 7.	On the Slave unit, set the RING TRIP/TRUNK/PAGE PORT switch to the same as the Master.
Step 8.	On the Slave unit, set the TALK BATTERY switch to OFF.
Step 9.	Connect a pair of wires from the TELCO OUT of the Master to the TELCO IN of the Slave.
Step 10.	Connect a pair of wires from the MUSIC OUT of the Master to the MUSIC IN of the Slave.
Step 11.	Connect a pair of wires from the OUTPUT CONTACTS of the Master to the INPUT CONTACTS of the Slave.
Step 12.	If night warble is desired through the Slave's zones, connect a pair of wires from the NIGHT RING or NIGHT CONTACTS (depending on which application you are using) of the Master to the NIGHT RING or NIGHT CONTACTS of the Slave. <b>Note:</b> In the Trunk/Page Port mode, the Slave's night warble volume should be set to minimum (fully counter-clockwise). The Master's night warble volume will control the Slave's zones. In Ring Trip mode, the Master and Slave's night warble volumes will work independently.
Step 13.	Set the TIME OUT ADJUSTMENT on the Slave to the maximum time (clockwise).
Step 14.	Plug the power supply adapter into the power jack of the Slave, and the other end into a wall outlet.

## D. Dip Switch Programming

**Note:** DIP switches should be set prior to powering up the ZPI-4. If power has already been applied, momentarily power down the unit so the switches will take effect.

DIP Switches  
OFF ON

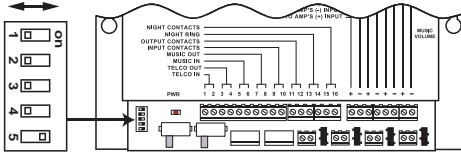

Switch	Position	Description
1	ON	Single amplifier
1	OFF	Two or more amplifiers *
2	ON	Two units
2	OFF	Single unit *
3	ON	Slave unit
3	OFF	Master unit *
4	ON	Dial tone enabled
4	OFF	Dial tone disabled *
5	ON	Page alert tone enabled *
5	OFF	Page alert tone disabled

## Operation

### A. Initiating a Page

#### 1. Ring Trip Paging

To access the ZPI-4 for ring trip paging, call the PABX/KSU station number the ZPI-4 is connected to. The ZPI-4 will answer on the first ring, produce dial tone (if enabled) and await Touch Tone entry for 10 seconds. If there is a Touch Tone entry, the ZPI-4 activates the selected zone(s). If there is no Touch Tone entry in 10 seconds, the ZPI-4 disconnects.

#### 2. Paging from an Unused Phone System Trunk Input

To make a page with the ZPI-4 installed on a spare trunk port, simply access the trunk connected to the ZPI-4. The ZPI-4 will produce dial tone (if enabled), wait for Touch Tone entry, and activate the selected zone(s) when it sees a Touch Tone entry.

#### 3. Paging from a Phone System's 600 Ohm Paging Port

To page in this situation, access the phone system's paging port. The ZPI-4 will detect that a page is being initiated and wait for a Touch Tone entry. When it sees an entry, it activates the selected zone(s).

Touch Tone	Zone(s)
1	1
2	2
3	3
4	4
5	1+2
6	2+3
7	3+4
8	1+2+3
9	2+3+4
0	1+2+3+4 (ALL)

### B. Selecting Zones

#### 1. Selecting Zones with One ZPI-4

Enter a single Touch Tone to select the zone or zones to be paged. After this entry has been made, the ZPI-4 activates the selected zone(s). See table to the right.

#### 2. Selecting Zones with Multiple ZPI-4's

To page all zones, enter a Touch Tone "0". The ZPI-4 will activate all zones to which it is connected. Otherwise, enter two Touch Tones, with the first selecting which ZPI-4 is being addressed, and the second selecting which zones connected to that ZPI-4 are to be paged. If a Touch Tone "1" is entered as the first digit, the Master is selected. If a Touch Tone "2" is entered as the first digit, the Slave is selected.

Touch Tone	Unit	Zone(s)
0	ALL	ALL

Touch Tone	Master Unit	Zone(s)
11	1	1
12	1	2
13	1	3
14	1	4
15	1	1+2
16	1	2+3
17	1	3+4
18	1	1+2+3
19	1	2+3+4
10	1	1+2+3+4 (ALL)

Touch Tone	Slave Unit	Zone(s)
21	2	1
22	2	2
23	2	3
24	2	4
25	2	1+2
26	2	2+3
27	2	3+4
28	2	1+2+3
29	2	2+3+4
20	2	1+2+3+4 (ALL)

## C. Paging

After there has been a Touch Tone entry, the **ZPI-4** activates the selected zones and produces a paging alert tone (if enabled). At this point the page can be spoken into the handset of the phone. In a **RING TRIP** or **PAGING PORT WITHOUT CONTACT CLOSURE** application, it is necessary to keep in mind that there is a time limit on the page, set by the **TIME OUT ADJUSTMENT**. Also, in these two applications, the VOX voice detect circuit will disconnect the page if three seconds of silence elapse during the page. When finished paging, either dial a touch tone # or simply hang up.

## D. Night / Loud Ringing

If a night ring contact closure is connected to **NIGHT CONTACTS**, or a night ring line is connected to the **NIGHT RING** terminals, the unit will produce a warble tone in all zones when a ring signal is detected. The priority of unit operation is as follows: 1) Loud Ring, 2) Voice Paging, 3) Background Music.

## Warranty

**IF YOU HAVE A PROBLEM WITH A VIKING PRODUCT, CONTACT: VIKING TECHNICAL SUPPORT AT (715) 386-8666**

Our Technical Support Department is available for assistance Monday 8am - 4pm and Tuesday through Friday 8am - 5pm central time. So that we can give you better service, before you call please:

1. Know the model number, the serial number and what software version you have (see serial label).
2. Have your Product Manual in front of you.
3. It is best if you are on site.

### RETURNING PRODUCT FOR REPAIR

The following procedure is for equipment that needs repair:

1. Customer must contact Viking's Technical Support Department at 715-386-8666 to obtain a Return Authorization (RA) number. The customer MUST have a complete description of the problem, with all pertinent information regarding the defect, such as options set, conditions, symptoms, methods to duplicate problem, frequency of failure, etc.
2. Packing: Return equipment in original box or in proper packing so that damage will not occur while in transit. Static sensitive equipment such as a circuit board should be in an anti-static bag, sandwiched between foam and individually boxed. All equipment should be wrapped to avoid packing material lodging in or sticking to the equipment. Include ALL parts of the equipment. C.O.D. or freight collect shipments cannot be accepted. Ship cartons prepaid to: **Viking Electronics, 1531 Industrial Street, Hudson, WI 54016**
3. Return shipping address: Be sure to include your return shipping address inside the box. We cannot ship to a PO Box.
4. RA number on carton: In large printing, write the RA number on the outside of each carton being returned.

### RETURNING PRODUCT FOR EXCHANGE

The following procedure is for equipment that has failed out-of-box (within 10 days of purchase):

1. Customer must contact Viking's Technical Support at 715-386-8666 to determine possible causes for the problem. The customer MUST be able to step through recommended tests for diagnosis.
2. If the Technical Support Product Specialist determines that the equipment is defective based on the customer's input and troubleshooting, a Return Authorization (R.A.) number will be issued. This number is valid for fourteen (14) calendar days from the date of issue.
3. After obtaining the R.A. number, return the approved equipment to your distributor, referencing the R.A. number. Your distributor will then replace the Viking product using the same R.A. number.
4. **The distributor will NOT exchange this product without first obtaining the R.A. number from you. If you haven't followed the steps listed in 1, 2 and 3, be aware that you will have to pay a restocking charge.**

## TWO YEAR LIMITED WARRANTY

Viking warrants its products to be free from defects in the workmanship or materials, under normal use and service, for a period of two years from the date of purchase from any authorized Viking distributor. If at any time during the warranty period, the product is deemed defective or malfunctions, return the product to Viking Electronics, Inc., 1531 Industrial Street, Hudson, WI., 54016. Customer must contact Viking's Technical Support Department at 715-386-8666 to obtain a Return Authorization (R.A.) number.

This warranty does not cover any damage to the product due to lightning, over voltage, under voltage, accident, misuse, abuse, negligence or any damage caused by use of the product by the purchaser or others. This warranty does not cover non-EWP products that have been exposed to wet or corrosive environments. This warranty does not cover stainless steel surfaces that have not been properly maintained.

**NO OTHER WARRANTIES.** VIKING MAKES NO WARRANTIES RELATING TO ITS PRODUCTS OTHER THAN AS DESCRIBED ABOVE AND DISCLAIMS ANY EXPRESS OR IMPLIED WARRANTIES OR MERCHANTABILITY OR FITNESS FOR ANY PARTICULAR PURPOSE.

**EXCLUSION OF CONSEQUENTIAL DAMAGES.** VIKING SHALL NOT, UNDER ANY CIRCUMSTANCES, BE LIABLE TO PURCHASER, OR ANY OTHER PARTY, FOR CONSEQUENTIAL, INCIDENTAL, SPECIAL OR EXEMPLARY DAMAGES ARISING OUT OF OR RELATED TO THE SALE OR USE OF THE PRODUCT SOLD HEREUNDER.

**EXCLUSIVE REMEDY AND LIMITATION OF LIABILITY.** WHETHER IN AN ACTION BASED ON CONTRACT, TORT (INCLUDING NEGLIGENCE OR STRICT LIABILITY) OR ANY OTHER LEGAL THEORY, ANY LIABILITY OF VIKING SHALL BE LIMITED TO REPAIR OR REPLACEMENT OF THE PRODUCT, OR AT VIKING'S OPTION, REFUND OF THE PURCHASE PRICE AS THE EXCLUSIVE REMEDY AND ANY LIABILITY OF VIKING SHALL BE SO LIMITED.

IT IS EXPRESSLY UNDERSTOOD AND AGREED THAT EACH AND EVERY PROVISION OF THIS AGREEMENT WHICH PROVIDES FOR DISCLAIMER OF WARRANTIES, EXCLUSION OF CONSEQUENTIAL DAMAGES, AND EXCLUSIVE REMEDY AND LIMITATION OF LIABILITY, ARE SEVERABLE FROM ANY OTHER PROVISION AND EACH PROVISION IS A SEPARABLE AND INDEPENDENT ELEMENT OF RISK ALLOCATION AND IS INTENDED TO BE ENFORCED AS SUCH.

**Product Support: (715) 386-8666**

Due to the dynamic nature of the product design, the information contained in this document is subject to change without notice. Viking Electronics, and its affiliates and/or subsidiaries assume no responsibility for errors and omissions contained in this information. Revisions of this document or new editions of it may be issued to incorporate such changes.