

# SERIE 402



ADVANCED TECHNOLOGY

MEMORY DIAL

WEATHERPROOF

VANDAL  
PROOF



REMOTE  
DIAGNOSTIC

REINFORCED  
COMPOSITE

FLASHING  
LIGHT

OPTIONAL EQUIPMENT  
\*VOIP EQUIPMENT  
\*HEADSET EQUIPMENT

HANDS FREE



LELAS  
GROUPE



[www.lelas.fr](http://www.lelas.fr)

+33 (0)1 48 76 62 62



**DESCRIPTION**

Weatherproof IP66 telephone for wall mounting, indoor and outdoor, for industrial and noisy environments.

■ **Electrical Characteristics:**

- DRY current supply: 12 to 60 Vdc
- Consumption: 15 to 45 mA
- Ringing voltage: 30-90 Vac
- Dialling: DTMF/PD
- Flashing: adjustable
- Electronic Bell: 84 to 92 dB at 1 m subject to model
- Flashing beacon: option
- Noise cancelling: noise cancelling circuit
- Hook: magnetic
- Conversation Mode: by handset/Hands free/Headphone
- Other characteristics: CCITT Q23

■ **Options**

- IP box
- Booster card +9 to 18 db
- Remote diagnostics
- Headphone
- Second receiver
- Handset cord 1m70

■ **Overall dimensions**

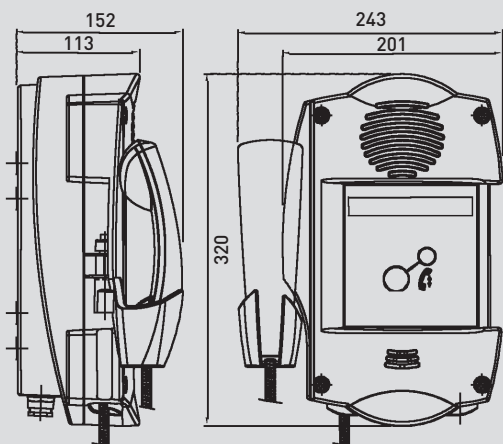

Security communication, voice optimization, latest technology performance, with this new range, LELAS favors once again the qualities that make it successful since 1909.

Low consumption but maximum power (double amplification Line and speaker), handset adaptable to the environment or completely hands-free version, high level of sealing and impact resistance, VoIP version, sub-assemblies removable for easy maintenance and all the accessories range LELAS, Serie 402 is already the industrial telephone terminal selected by the most demanding users.

Easy installation, connection, accessories, climatic conditions resistant components, stainless steel fastenings, filled composite shockproof, keyboard, display, memory call, flashing beacon, remote diagnosis by PC station, this range makes you enjoy the whole experience of LELAS and offers to all our products guarantee part and labor three years.

**CHARACTERISTICS**

- Body material / color: polyester plastic / RAL2003
- Handset material / color: polyester plastic / black
- Handset cord: stainless steel 100 kg resistance
- Microphone: Electret type waterproof
- Loudspeaker (hands-free): 50 Ω / 5 watts shock and weatherproof
- power → 80 db to 1 m
- Mounting: on wall (2 or 4 fixing holes)
- Termination: inside screw connections
- Cable type: single wire or multi wire max 1.5 mm<sup>2</sup>
- Cable entry: type waterproof cable Ø10 to Ø13 mm
- Dimensions: 201 x 320 x 113 mm
- Weight: 2.3 kg
- IP-rating: IP66
- Impact rating (IK): 10
- EEx protection: no
- Max. / min. amb. temp: -40°C / + 70°C

**REFERENCES**

Model	Handset	Hands-free	Display	Simple Keyboard	Db function Keyboard	1 button	Flashing beacon	Remote diagnostics
TLC402E1	●							
TLA402E1	●			●				
TLA402E1F	●			●			●	
TLS402E2C9FGL	●	●	●		●		●	●
TLS402E2B		●				●		●
TLS402E2C9FL		●	●		●		●	●



Conforming to the EEC standards

